

ACCESSORY KIT INSTALLATION INSTRUCTIONS

Low Ambient Accessory For Air Cooled Split-System Air Conditioners HA 300, HB 360 / 480 / 600, HF-25, HL-30 / -40 / -50 Models

GENERAL

These split-system condensing units are designed to operate at ambient temperatures down to 40°F. This accessory will insure safe operation at ambient temperatures down to 0°F. The VLT6000 control monitors the refrigerant system and will vary the condenser fan speed based on the discharge pressure. One controller is required for each fan to be controlled. Therefore, one accessory kit would be required to control each refrigerant circuit. Two kits are required if both refrigerant circuits are to be operated below 40°F. This instruction provides all the necessary information to properly field-install a low ambient accessory on the condensing units listed in Table 1. Components that are supplied in the respective accessory are listed in Table 2, and pictured in Figure 1



TABLE 1: APPLICATION DATA

ACCESSORY MODEL #	VOLTAGE	UNIT
2LA04702658	575	HA 300, HF-25
2LA04702858	575	HB 360, HL-30
2LA04702958	575	HB 480, HL-40
2LA04703058	575	HB 600, HL-50

TABLE 2: ACCESSORY COMPONENTS

ITEM	QTY.	PART NO.	DESCRIPTION
1*	1* ea.	473-24615-00X*	VLT6000 Condenser Fan Speed Control and Enclosure
2	1 ea.	025-38680-000	Pressure Transducer
3	1 ea.	025-38681-000	Wire Harness Assembly
4	1 ea.	025-37466-000	Power Wire Harness
5	1 ea.	023-20566-000	Tee Connector
6	2 ea.	021-15529-000	Screw HEX ¼-14 X.75
7	1 ea.	025-10209-000	7/8 Bushing
8	2 ea.	025-14284-000	1 3/8 Bushing
9	6 ea.	025-09607-000	Wire Tie
10	1 ea.	025-37455-000	0° Degree Switch
11†	2 ea.	025-37425-575	30/40 Ton Crankcase Heater
	2 ea.	025-37474-575	25/50 Ton Crankcase Heater

*. "X" denotes Model number needed for application.

†. Crankcase Heaters supplied are dependent on accessory ordered.

FIGURE 1 - ACCESSORY COMPONENTS

⚠ WARNING

The 2LA047 series low ambient accessories are intended for use with the 25-50 Ton Split System condensing units only. UPG cannot guarantee proper operation for any application of this VLT6000 controller for other equipment or applications. Contact your local branch or distributor for any application related questions.

⚠ WARNING

Improper installation, adjustment, service or maintenance can cause injury or property damage. Therefore, only a qualified installer or qualified service personnel should perform this conversion.

⚠ WARNING

If the unit is connected to power sources, make sure that all electrical power to the unit has been disconnected.

1. Disconnect all electrical power to the unit.
2. Remove the condensing unit control box access panel.

⚠ WARNING

Before installing accessory read all of this installation instruction.

3. Install the VLT6000 enclosure with the provided screws. Mounting holes are pre-punched in the top rails to locate the enclosure near the condensing unit control box. See Figure 7.

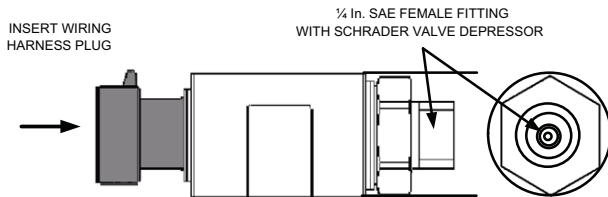

FIGURE 2 - PRESSURE TRANSDUCER

⚠ CAUTION

Do not remove the plastic plugs from the transducers until they are ready to be installed.

4. Attach the pressure transducers to the connection tee (provided in accessory). The pressure transducer has a 1/4 In. SAE female flare with Schrader valve depressor for mounting to the tee. See Figure 2.
 - Hand thread the transducer to the tee.
 - Tighten and secure the connection.
 - Remove the Schrader valve cap from the discharge line port (provided).
 - Hand thread the tee to the discharge line port.
 - Tighten and secure the connection, making sure the transducer is mounted vertically. See Figure 3.
 - Perform a leak test on fittings and connections before putting the system into operation.

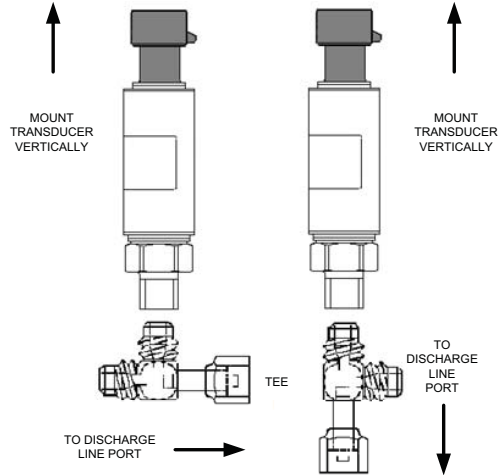

FIGURE 3 - PRESSURE TRANSDUCER MOUNTING

NOTE: This procedure must be repeated for each system.

5. Attach wiring harness assembly plug to transducer. See Figure 4. Route sensor wires back to VLT6000 enclosure.

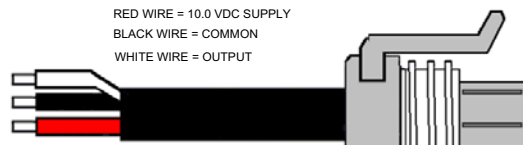

FIGURE 4 - WIRE HARNESS ASSEMBLY

6. Remove VLT6000 enclosure lid.
7. Pass wires through the bushing (provided), using knock out located in the bottom of the VLT6000 enclosure.
8. Access the VLT6000 control terminal blocks. See Figure 6.
9. Remove the terminal access cover. See Figure 5.

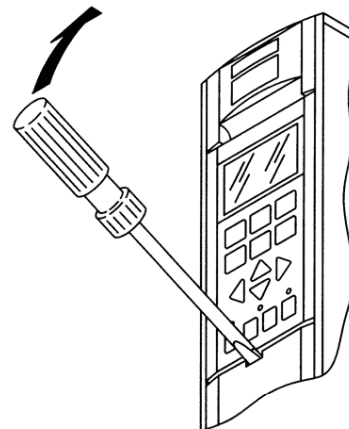

FIGURE 5 - VFD66 CONTROL TERMINAL BLOCKS

10. Wire transducers to the VLT6000 control. See Figure 6.

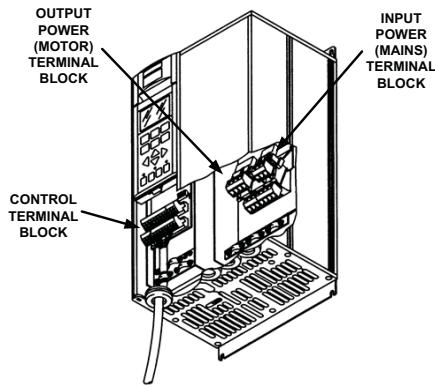

FIGURE 6 - P399 PRESSURE TRANSDUCER WIRING

- Route power wires, motor leads, and transducer signal wires through separate knockouts. See Figure 6.
- Connect White Wire from Transducer to Terminal (53) on the VLT6000.
- Connect Black Wire from Transducer to Terminal (55).
- Connect Red Wire from Transducer to Terminal (50).
- Connect Bare (shield) Wire from Transducer to Grounding Terminal.

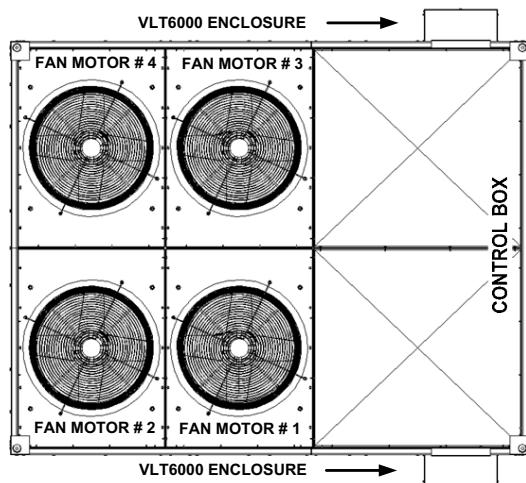

FIGURE 7 - FAN MOTOR #1 LOCATION

NOTE: All Wiring must comply with prevailing Local and National wiring codes and ordinances.

11. Cut two lengths of flexible conduit (Field Supplied) to connect from the VLT6000 Control to the condensing unit control box.
- Conduit #1 should run from the bottom of the VLT6000 enclosure to the condensing unit control box, using knock outs provided.

- In conduit #1 insert three # 14 Gage wires marked on both ends (field supplied).
- Conduit #2 should run from the bottom of the VLT6000 enclosure to the condensing unit control box, using knock outs provided.
- In conduit #2 insert shielded power cable supplied in accessory.
- Allow additional conduit length to remove the VLT Control enclosure from the top rail and place on side for servicing.

12. Wire condenser fan motor #1 to the VLT6000 control. See Figure 6, and the SWD in Figure 9. The VLT6000 must be wired to operate fan motor #1. Factory installed pressure switches control fan motor #2.

- Disconnect wire 136/BLK from terminal (T1) on contactor (M5).
- Disconnect wire 137/BRN from terminal (T2) on contactor (M5).
- Disconnect wire 138/PR from terminal (T3) on contactor (M5).
- Extend wire 136/BLK to terminal (96 / U) located on the VLT6000 control using wires in conduit #1.
- Extend wire 137/BRN to terminal (97 / V).
- Extend wire 138/PR to terminal (98 / W).
- Connect (BLK) wire of power harness to terminal (T1) on contactor (M5) and to terminal (91 / L1) on the VLT6000 control using shielded cable in conduit #2.
- Connect (RED) wire of power harness to terminal (T2) on contactor (M5) and to terminal (92 / L2).
- Connect (WHT) wire of power harness to terminal (T3) on contactor (M5) and to terminal (93 / L3).
- Connect bare wire of power harness to the grounding terminal on VLT6000 control.

13. The activation pressures are preset at the factory. See Drive parameters below.
14. Remove existing low ambient switch (LAS) (See Figure 8), located in the unit control box, and replace with new 0° low ambient switch (provided).
15. Install additional crankcase heaters on the compressors of the system to which the VLT6000 control is to be applied. Wire each additional heater parallel to the existing heater, utilizing the existing ground.
16. Secure wiring in the unit control box in a neat workman like manner using wire ties.
17. Replace terminal access cover on VLT6000 control.
18. Replace lid on VLT6000 enclosure.

19. Close unit control box by replacing unit access panel and restore power to the unit.

20. Verify proper unit operation.

A call for cooling closes the (M5) contactor powering the VLT6000 control. As the discharge pressure rises above 210 PSI. during startup, the VLT6000 control will increase the speed of the condenser fan accordingly.

The unit's scroll compressor produces a rapid rise in discharge pressure upon startup and this, depending on the ambient temperature, will result in full speed operation of the condenser fan. After the discharge pressure has stabilized, the speed of the condenser fan may decrease especially during times when the ambient temperature is below 80°F. If the discharge pressure has stabilized and an additional compressor is energized, the speed of the condenser fan may increase, compensating for the rise in discharge pressure.

As the discharge pressure begins to fall below the 210 PSI. setpoint, the drive will reduce the speed of the condenser fan.

As the ambient temperature drops below 40°F the condenser fan will slow to the minimum speed. The pressure controlled condenser fan will disengage when the discharge pressure drops below 180 PSIG as the ambient temperature falls. The system discharge pressure will increase when the condenser fan is disengaged causing the VLT6000 control to increase the condenser fan speed.

21. Contact your local branch or distributor for questions regarding installation.

NOTE: VLT6000

See Table 3 for the parameter settings in the drive. For specific instructions on the VLT6000, refer to the Danfoss manual shipped with the kit.

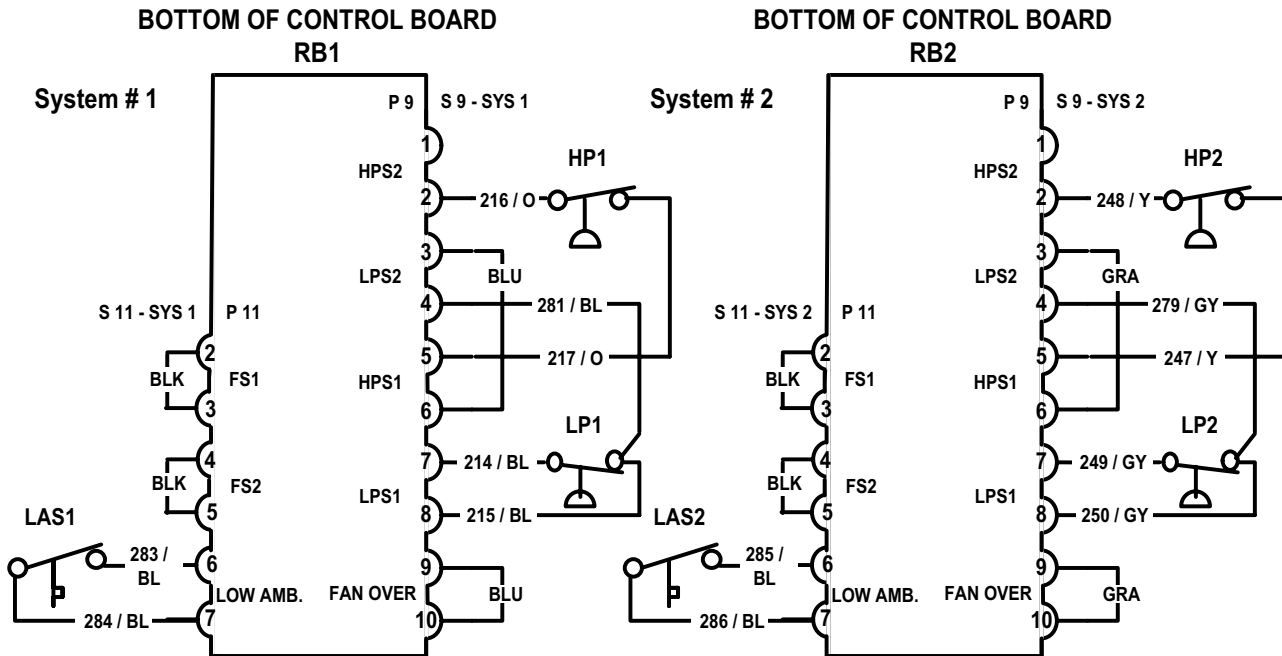

FIGURE 8 - LAS-LOW AMBIENT SWITCH WIRING LOCATIONS

* Single control board (RB1) applies to 25-Ton unit only.

**Dual control board (RB1 & 2) apply to 30, 40 & 50 Ton units.

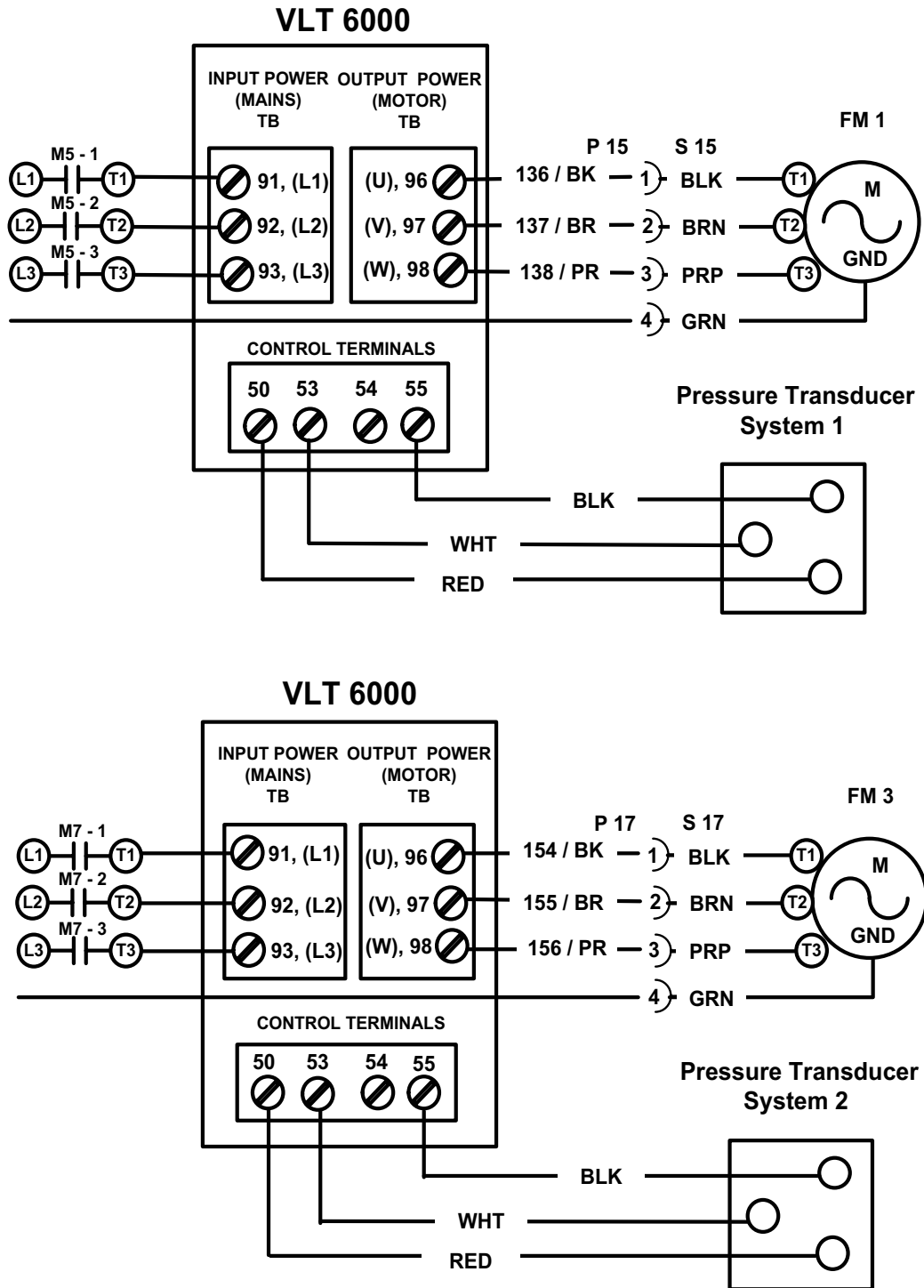

FIGURE 9 - SIMPLIFIED WIRING DIAGRAM

TABLE 3: PARAMETER SETTING

Parameter	Condenser Fan	
2	Setup #1	Active setup
6	PSI 2	What the readout will show
7	CUSTOM READ [UNITS]	Main display will show system pressure
8	Reference (unit)	Top Left Display (drive reference: open loop = Hz; closed loop = in WG)
9	Frequency [%]	Top Middle Display (closed loop = actual pressure)
10	Motor Current (A)	Top Right Display (motor current in Amps)
100	Closed Loop	Feedback from transducer controls speed
101	AEO Function	Motor torque curve
102	1.1	Motor Power (1.1 kw = 1.5hp)
103	575	Motor Voltage
104	60	Motor Frequency
105	2.3	Motor Current
106	1140	Rated Motor Speed
201	20 Hz	Minimum Motor Speed Frequency
202	60 Hz	Maximum Motor Speed Frequency
204	0	Minimum allowable setpoint, equal to parameter 413 in closed loop
205	500	Maximum allowable setpoint, equal to parameter 414 in closed loop
206	5 seconds	Ramp up time
207	10 seconds	Ramp down time
209	-	Frequency to operate upon loss of analog input signal
210	External/preset	Reference location (external transducer)
211	0	Preset reference 1
212	0	Preset reference 2
213	0	Preset reference 3
214	0	Preset reference 4
216	1	Frequency bypass bandwidth
217	41	Frequency bypass 1 (skip 41 Hz motor speed)
300	No operation	Digital input 16
301	No operation	Digital input 17
302	Start	Jumper terminal 12 or 13 to terminal 18 to start the drive whenever powered
303	No operation	Digital input 19
304	Coast inverse	Jumper terminal 12 or 13 to terminal 27 to enable to drive to run
305	No operation	Digital input 29
306	No operation	Digital input 32
307	No operation	Digital input 33
308	Feedback	Pressure transmitter 1 is wired to terminal 53
309	0 VDC	Transmitter voltage at minimum pressure
310	10 VDC	Transmitter voltage at maximum pressure
311	Feedback	Pressure transmitter 2 is wired to terminal 54
312	0 VDC	Transmitter voltage at minimum pressure
313	10 VDC	Transmitter voltage at maximum pressure
314	No operation	Assumes terminal 60 is not used
315	0 mA	

TABLE 3: PARAMETER SETTING (CONTINUED)

Parameter	Condenser Fan	
316	20 mA	
317	2 seconds	Length of time analog input must be gone before the drive reacts
318	No function	How the drive reacts on loss of analog input (only works if minimum voltage is greater than 0)
400	Infinite Automatic	Reset function
402	Enable	Flying start
403	Off	Length of time to run at minimum speed before shutting off (part of sleep mode)
404	-	Set about 1 Hertz above 201 (part of sleep mode)
405	-	Frequency to turn back on (part of sleep mode)
406	-	
413	0 psi	Pressure value at minimum transducer signal
414	500 psi	Pressure value at maximum transducer signal
415	PSI 2	Text string to display on the keypad
417	MAX	Feedback function
418	210 psi	Desired pressure to maintain
420	Inverse	Control response; "inverse" = motor speed will increase when pressure increases
421	Enable	PID antiwindup
422	20 Hz	PID Start Frequency
423	2	Proportional gain
424	3	Integral time
425	Off	Differential time (leave OFF)
427	0.02	First order filter on feedback signal

Subject to change without notice. Printed in U.S.A.
Copyright © by Unitary Products Group 2007. All rights reserved.

98955-UAI-B-0107
Supersedes: 98955-UAI-A-0904/035-20209-000-A-0904

**Unitary
Products
Group**

**5005
York
Drive**

**Norman
OK
73069**