

# INSTALLATION MANUAL

## CONTENTS

GENERAL .....	3
REFERENCE .....	3
INSTALLATION .....	6
START-UP .....	10
MAINTENANCE .....	11

See the following page for a complete Table of Contents.

## NOTES, CAUTIONS AND WARNINGS

The installer should pay particular attention to the words: *NOTE*, *CAUTION*, and *WARNING*. Notes are intended to clarify or make the installation easier. Cautions are given to prevent equipment damage. Warnings are given to alert installer that personal injury and/or equipment damage may result if installation procedure is not handled properly.

**CAUTION:** READ ALL SAFETY GUIDES BEFORE YOU BEGIN TO INSTALL YOUR UNIT.

SAVE THIS MANUAL

## ELECTRIC HEAT ACCESSORY 10, 20, 30, & 50 kW FOR SPLIT-SYSTEM AIR HANDLERS

**MODELS:** LEU/LBC 240 & J20L\*EU  
FEH/FHP 180/240 & J15, 20F\*EH

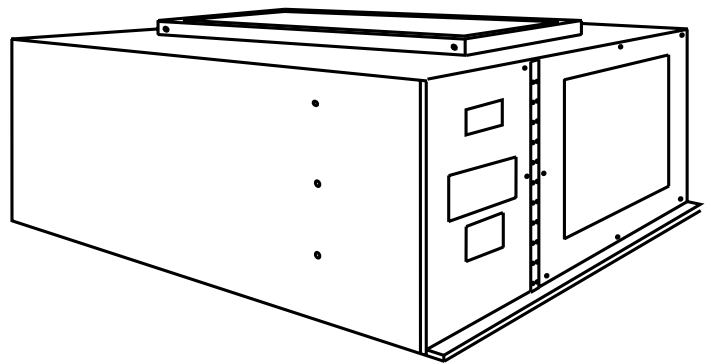

## TABLE OF CONTENTS

<b>GENERAL</b> .....	<b>3</b>
NOTES, CAUTIONS AND WARNINGS .....	3
<b>REFERENCE</b> .....	<b>3</b>
<b>INSTALLATION</b> .....	<b>6</b>
SPLIT SYSTEM HEAT PUMPS .....	6
FREE STANDING UNITS WITH A SUPPLY AIR PLENUM ACCESSORY .....	7
180 MBH DUCT-MOUNTED UNITS .....	7
FREE STANDING UNITS WITH A SUPPLY AIR PLENUM ACCESSORY AND ELECTRIC HEAT .....	8
ELECTRICAL COMPONENTS .....	8
<b>START-UP</b> .....	<b>10</b>
<b>MAINTENANCE</b> .....	<b>11</b>

### LIST OF FIGURES

<u>Fig. #</u>	<u>Pg. #</u>
1 HEATER INSTALLATION FOR 15 TON DISCHARGE .....	4
2 HEATER INSTALLATION FOR 20 TON DISCHARGE .....	4
3 FOAM GASKET LOCATION .....	6
4 WIRING DIAGRAM .....	10
5 CONTACTOR BOX & HARNESS SUPPORT .....	11
6 HEATER DIMENSIONS .....	11

### LIST OF TABLES

<u>Tbl. #</u>	<u>Pg. #</u>
1 HEATING CAPACITY 180 .....	5
2 HEATING CAPACITY 240 .....	5
3 TERMINAL CONNECTIONS .....	7
4 PHYSICAL DATA .....	7
5 ELECTRICAL RATINGS INDOOR UNITS WITH ELECTRIC HEAT .....	9
6 AUTOMATIC RESETS .....	9
7 HEATER DIMENSIONS .....	11

## GENERAL

This instruction covers the installation and operation of these electric heat accessories.

Every electric heat accessory is shipped completely assembled and pre-wired with all of the power and control wiring that will be required to interconnect this accessory with the basic unit. Refer to Tables 1 and 2 for accessory model numbers and for capacity ratings based on the voltage of the power supply and the mode of operation.

These electric heaters can be installed on either vertical or horizontal units, on units with ductwork, or on free standing units equipped with a supply air plenum accessory.

**NOTE:** The Electric Heat Accessory is UL approved for use with LEU/LBC 240 & J20L\*EU Cooling Air Handlers and on FEH/FHP 180/240 & J15, 20F\*EH Heat Pump Air Handlers only.

**NOTE:** The Electric Heat Accessory is not UL approved on free standing units equipped with a Supply Air Plenum Accessory.

Split-system units equipped with an electric heat accessory will require only one power supply for both the heater elements and the supply air blower motor. Refer to Figure 1A and 1B for the locations of both the power and the control wire access openings and to the

following instructions for routing and connecting the wires.

All heat pump systems with one of these electric heat accessories will require a special thermostat. Refer to the field wiring diagram on Page 10 to determine the proper thermostat model number.

**NOTE:** Heat pump systems with or without electric heat use the same thermostats.

When an indoor unit is equipped with an electric heater, provide at least 1-inch clearance to combustible material around heater cabinet, supply air plenum and supply air ducts up to 3 feet from the unit.

## NOTES, CAUTIONS AND WARNINGS

The installer should pay particular attention to the words: *NOTE*, *CAUTION*, and *WARNING*. Notes are intended to clarify or make the installation easier. Cautions are given to prevent equipment damage. Warnings are given to alert installer that personal injury and/or equipment damage may result if installation procedure is not handled properly.

## REFERENCE

Refer to the indoor section instructions for additional information on the installation of the basic unit, for the application limitations of the total system and for the minimum clearance requirements of the indoor unit.

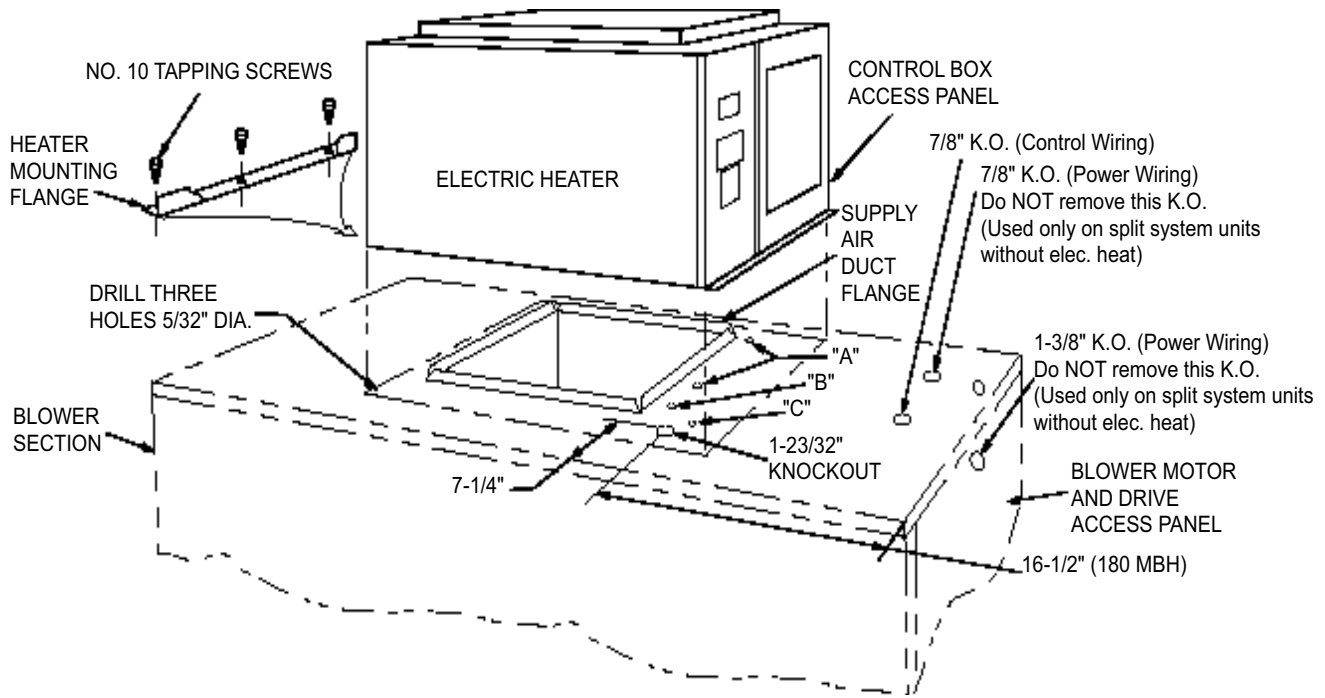

FIGURE 1 - HEATER INSTALLATION FOR 15 TON DISCHARGE

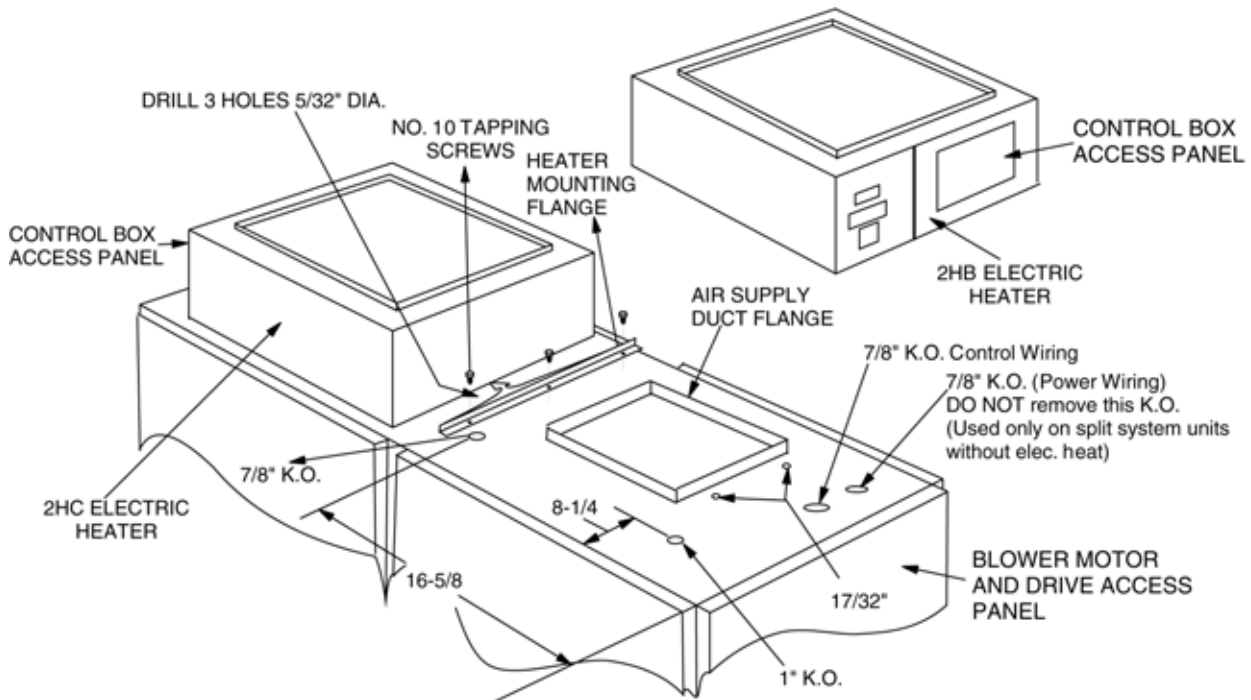

FIGURE 2 - HEATER INSTALLATION FOR 20 TON DISCHARGE

TABLE 1: HEATING CAPACITY 180

Heater Model 2HB0450-	Heater Ratings		Power Supply	Heating Capacity <sup>1</sup>							
	KW	Volts		Nominal		Defrost		Supplemental		Standby	
				KW	MBH	KW	MBH	KW	MBH	KW	MBH
1025	10	240	208-3-60	7.51	25.64	7.51	25.64	7.51	25.64	7.51	25.64
			230-3-60	9.18	31.35	9.18	31.35	9.18	31.35	9.18	31.35
1046	10	480	460-3-60	9.18	31.35	9.18	31.35	9.18	31.35	9.18	31.35
2025	20	240	208-3-60	15.02	51.27	--	--	--	--	15.02	51.27
			230-3-60	18.37	62.69	--	--	--	--	18.37	62.69
2046	20	480	460-3-60	18.37	62.69	--	--	--	--	18.37	62.69
3025	30	240	208-3-60	22.53	76.91	--	--	--	--	22.53	76.91
			230-3-60	27.55	94.04	--	--	--	--	27.55	94.04
3046	30	480	460-3-60	27.55	94.04	--	--	--	--	27.55	94.04
5025	50	240	208-3-60	37.56	128.18	--	--	--	--	37.56	128.18
			230-3-60	45.92	156.73	--	--	--	--	45.92	156.73
5046	50	480	460-3-60	45.92	156.73	--	--	--	--	45.92	156.73

<sup>1</sup>. Capacity ratings do not include the heat generated by the supply air blower.

TABLE 2: HEATING CAPACITY 240<sup>1</sup>

Heater Mode 2HB0450 & 2HC0450I -	Heater Ratings		Power Supply	Heating Capacity <sup>2</sup>							
	KW	Volts		Nominal		Defrost		Supplemental		Standby	
				KW	MBH	KW	MBH	KW	MBH	KW	MBH
1025 & 1025	20	240	208-3-60	15.02	51.27	--	--	--	--	15.02	51.27
			230-3-60	18.37	62.69	--	--	--	--	18.37	62.69
1046 & 1046	20	480	460-3-60	18.37	62.69	--	--	--	--	18.37	62.69
2025 & 1025	30	240	208-3-60	22.53	76.91	--	--	--	--	22.53	76.91
			230-3-60	27.55	94.04	--	--	--	--	27.55	94.04
2046 & 1046	30	480	460-3-60	27.55	94.04	--	--	--	--	27.55	94.04
2025 & 2025	40	240	208-3-60	30.04	102.54	--	--	--	--	30.04	102.54
			230-3-60	36.74	125.38	--	--	--	--	36.74	125.38
2046 & 2046	40	480	460-3-60	36.74	125.38	--	--	--	--	36.74	125.38
3025 & 2025	50	240	208-3-60	37.56	128.18	--	--	--	--	37.56	128.18
			230-3-60	45.92	156.73	--	--	--	--	45.92	156.73
3046 & 2046	50	480	460-3-60	45.92	156.73	--	--	--	--	45.92	156.73

<sup>1</sup>. The 2HB model will go on the drive side of the unit and the 2HC model will go on the opposite side. This will allow access into each heater via the access panel.

<sup>2</sup>. Capacity ratings do not include the heat generated by the supply air blower motor.

## INSTALLATION

### SPLIT SYSTEM HEAT PUMPS

Install these electric heat accessories per the following step-by-step procedures and the illustrations shown in Figures 1, 2 and 4.

1. Remove the electric heat accessory from its shipping container.

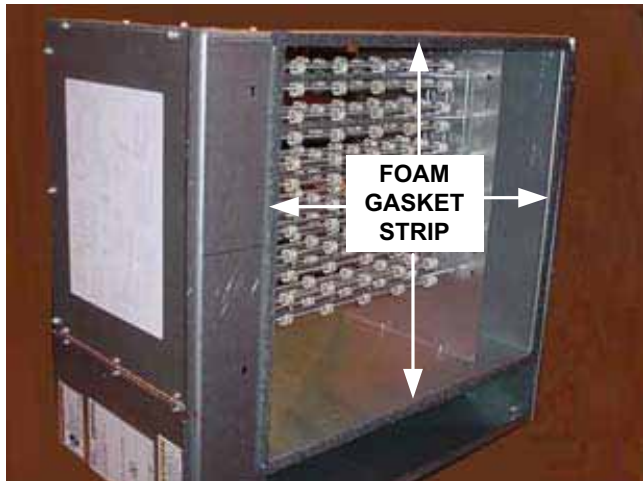

**FIGURE 3 - FOAM GASKET LOCATION**

2. Install foam gasket. (See Figure 3.)
3. Remove the control box access panel from the heater cabinet.
4. Remove the access panel of the blower motor compartment from the indoor unit for access to the blower motor contactor box and low voltage terminal block TB1. (Refer to Figure 2.)
5. Remove the cover from the blower motor contactor box.
6. Remove the 1-23/32" knockout from the top of the indoor unit. Refer to Figure 1 for its exact location.
7. Remove the two screws from the "A" locations and save them for step 10.
8. Set the heater cabinet on top of the unit as shown in Figure 1 or 2. Route its wiring harness through the knockout removed per step 6.

### CAUTION

DO NOT remove the screw from location "B".

On the 180 MBH unit, this screw is outside the dimensions of the heater accessory and will not interfere with its installation.

9. Position the heater so that:
    - a. The duct flanges around the unit's supply air opening fit into the heater opening.
    - b. The strain relief bushing on the bottom of the heater control box fits into the 1-23/32" opening. (Knockout removed per step 6.)
    - c. The three holes in the bottom of the heater control box align with the three holes on the top of the unit - the two holes at the "A" locations and the hole at location "C".
  10. Secure the heater to the unit at the holes aligned per step 9 (d) using the two screws removed per step 7, and 1 of the #10 x 1/2" screws provided with the accessory.
  11. Drill three 5/32" holes through the top of the unit using the holes in the mounting flange on the opposite end of the heater as templates.
  12. Secure the heater to the unit at these locations using the three remaining #10 x 1/2" screws provided with the accessory.
  13. Remove the 7/8" knockout from the back panel of the contactor box (at the top for 180 MBH units) and insert the 1/2" strain relief bushing, provided with the accessory, into this opening. (Refer to Figure 2.)
- NOTE:** The clamp portion of the bushing must extend out the back of the contactor box.
14. Route line voltage wires 724B, 725B and 726B of the heater wiring harness through the bushing installed per step 13, connect them to the terminals on contactor 10M, and tighten the bushing to secure the wires to the contactor box.

15. Route the control voltage wires of the heater wiring harness through the snap bushing and connect them to the proper terminals on terminal block TB1 per the following.

**TABLE 3: TERMINAL CONNECTIONS**

Heater Rating kW	Terminal Designation on TB1 (Split System)			
	C	W1	HR	HC
10	806/BL	801/W	811/BK	804/BK
20	806/BL	801/W	811/BK	804/BK
30	806/BL	801/W	811/BK	804/BK
50	806/BL	801/W	811/BK	804/BK

16. Secure the wiring harness to the support angle with the two ty-raps provided with the accessory. Holes are pre-punched in the support at the locations shown in Figure 2.

17. Add a conduit fitting (field-supplied) to the power access opening in the rear panel of the heater cabinet per Figure 5.

18. Install the field wiring per the following instructions and the appropriate connection diagram on Page 10.

19. Replace the contactor box cover removed per step 5, the indoor unit access panel removed per step 4 and the heater control box cover removed per step 3.

**TABLE 4: PHYSICAL DATA**

DESCRIPTION		CAPACITY					
		10kW	20kW	30kW	40kW	50kW	
Heater Elements	% Nickel	59.2					
	% Chromium	16.0					
	Coil ID - in.	9/32					
	Watt Density (Watts/sq.ft.)	59					
	Face Area (sq. ft.)	3.0					
	Rows Deep	1	2	3	4	5	
Weight	Shipping - LBS	63	66	71	74	120	
Fuses <sup>1</sup>	208/230 Volts	Quantity	3	3	3/3	6	12
		Size Amps	45	60	60/45	60	60
	460 Volts	Quantity	3	3	3	3	6
		Size Amps	25	30	45	60	60

1. Dual elements time delay fuses. The National Electric Code requires the electric heat power supplies be subdivided into branch circuits of no more than 48 amps.

### FREE STANDING UNITS WITH A SUPPLY AIR PLENUM ACCESSORY

Remove the 2-1/2" knockout from the rear panel of the plenum, route the power wire conduit through this opening and connect it to the fitting installed per step 17, route the power wiring into the heater control box, and connect the power and ground wires per the field wiring diagram.

Route the control wires from the thermostat and the outdoor unit through the bushing in the 7/8" hole in the rear panel of the indoor unit. (See Figure 1 for its location.) Connect these wires to terminal block 4TB per the field wiring diagram.

### 180 MBH DUCT-MOUNTED UNITS

Connect the power wire conduit to the fitting installed per step 17, route the power wiring into the heater control box, and connect the power and ground wires per the field wiring diagram.

Remove the 7/8" knockout for control wiring from the top panel of the indoor unit. (See Figure 1 for its location.) Add a 1/2" strain relief bushing (field supplied) to this opening, route the control wires from the thermostat and the outdoor unit through this bushing, connect them to terminal block 4TB per the field wiring diagram, and tighten the bushing to secure the control wiring to the unit.

## **FREE STANDING UNITS WITH A SUPPLY AIR PLENUM ACCESSORY AND ELECTRIC HEAT**

Remove the 2-1/2" knockout and one of the 7/8" knockouts from the rear panel of the plenum. Route the power wire conduit through the 2-1/2" opening and connect it to the fitting installed per step 17, route the power wiring into the heater control box, and connect the power and ground wires per the field wiring diagram.

Remove the 7/8" knockout for control wiring from the top panel of the indoor unit. (See Figure 1 for its location.) Add a 1/2" strain relief bushing (field supplied) to this opening and to the 7/8" opening in the rear of the plenum.

Route the control wires from the thermostat and the outdoor unit through these bushings, connect them to terminal block 4TB per the field wiring diagram, and tighten both bushings to secure the control wiring to the unit.

Replace the control box access panel removed in step 3, the blower motor access panel removed in step 4, and the electrical box access panel removed in step 5.

## **ELECTRICAL COMPONENTS**

These electric heat accessories include staging contactors, back-up contactors and two high limit controls (1LC and 2LC).

Staging contactors are energized through the system control circuit. When energized, each contactor will close two of three legs to one or two of the heating elements. This arrangement is illustrated in the wiring labels for the electric heat accessories.

Back-up contactors are not energized through the system control circuit. They will be closed as long as there is power to the electric heat control circuit and both high limit controls are closed.

The high limit controls will prevent the electric heat accessory from operating at an excessive temperature. They will open and reset automatically at the temperatures listed in Table 5.

**TABLE 5: ELECTRICAL RATINGS INDOOR UNITS WITH ELECTRIC HEAT<sup>1</sup>**

BLOWER MOTOR HP	NOMINAL HEATER kW	POWER SUPPLY	HEATER FLA	MIN. CIRCUIT AMPACITY	MAX. FUSE SIZE <sup>2</sup>	MIN. DISCONNECT AMPS
180 w/3 HP MOTOR	10kW	208-3-60	20.8	35.5	40	60
		230-3-60	23.1	38.1	40	60
		460-3-60	11.5	19.0	20	30
	20kW	208-3-60	41.6	61.5	70	60
		230-3-60	46.2	66.9	70	100
		460-3-60	23.1	33.5	35	60
	30kW	208-3-60	62.5	87.6	90	100
		230-3-60	69.3	95.8	100	100
		460-3-60	34.6	47.8	50	60
	50kW	208-3-60	104.4	140.0	150	150
		230-3-60	115.2	153.2	175	150
		460-3-60	57.6	76.6	80	100
240 w/5 HP MOTOR	20kW	208-3-60	41.6	68.0	70	100
		230-3-60	46.2	70.6	80	100
		460-3-60	23.1	35.3	40	60
	30kW	208-3-60	62.5	94.1	100	100
		230-3-60	69.3	99.4	100	100
		460-3-60	34.6	49.7	50	60
	40kW	208-3-60	83.3	120.1	125	150
		230-3-60	92.1	127.9	150	150
		460-3-60	46.1	64.0	70	100
	50kW	208-3-60	104.4	146.5	150	150
		230-3-60	115.2	156.8	175	150
		460-3-60	57.6	78.4	80	100

1. Unit with an electric heat accessory will always be wired for a single power supply.

2. Maximum fuse or maximum circuit breaker (HACR type per NEC).

### WARNING

When the staging contactors are de-energized, one of the legs to each heating element is "HOT". Open the main disconnect switch before servicing the heating accessory.

**TABLE 6: AUTOMATIC RESETS**

High Limit Control	Location	2HB & 2HC	
		Opens	Closes
1LC	Entering	140°F	90°F
2LC	Leaving	150°F	100°F

## START-UP

Make sure that all electrical connections are tight before closing the disconnect switch to the indoor unit.

Close the disconnect switch and check the operation of each heating stage.

Check the total unit CFM in accordance with the respective basic unit instruction as referenced on Page 6. Refer to the Static Resistances table for these electric heaters.

De-energize the electric heat accessory after it has been operating for several hours, and recheck all of the electrical connections for tightness.

**CAUTION**

Failure to properly adjust the supply air CFM could cause nuisance tripping of the high limit controls.

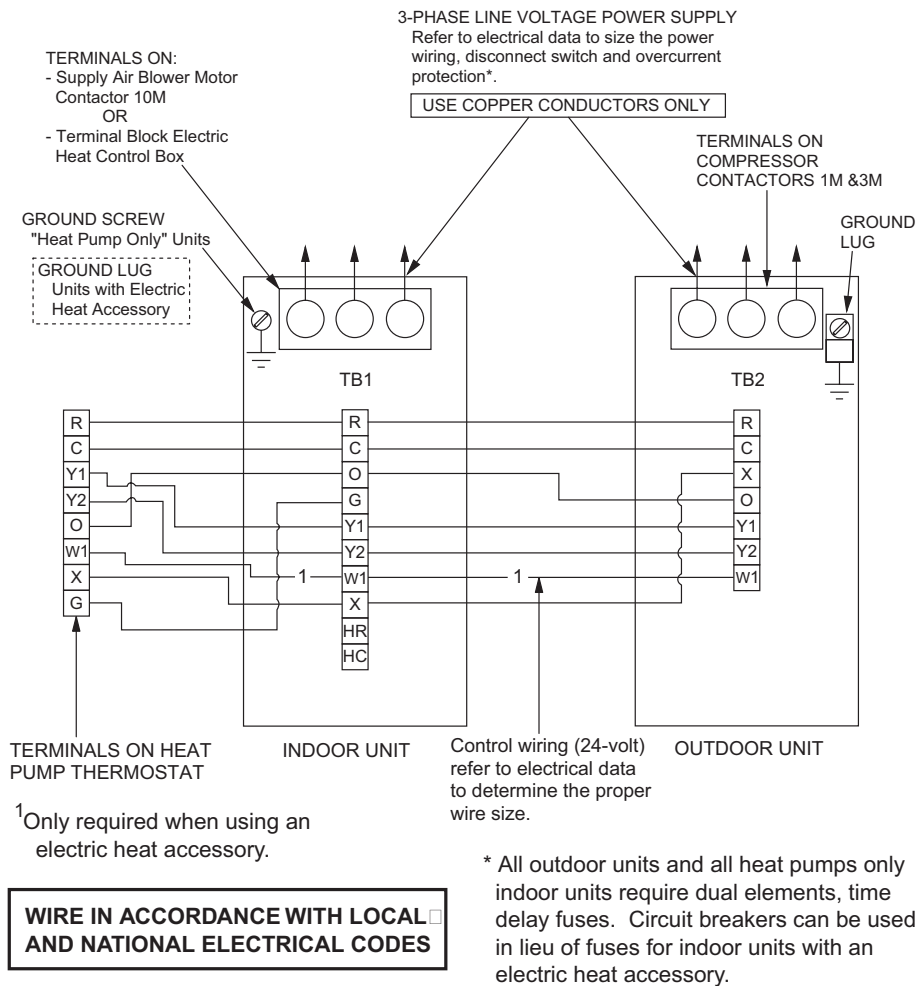
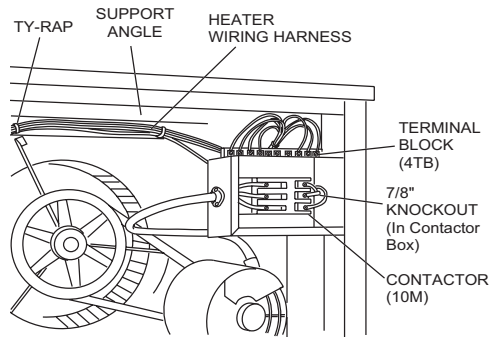

**FIGURE 4 - WIRING DIAGRAM**

## MAINTENANCE

Although these electric heat accessories do not require any specified maintenance, the factory recommends a semi-annual inspection of all components to see if they are functioning properly.

Check all unit filters periodically for dirt accumulation. Dirty filters will restrict air flow and could cause nuisance tripping of the high limit controls. Filters must be changed as often as necessary to assure good air flow and filtering action.



**FIGURE 5 - CONTACTOR BOX & HARNESS SUPPORT**

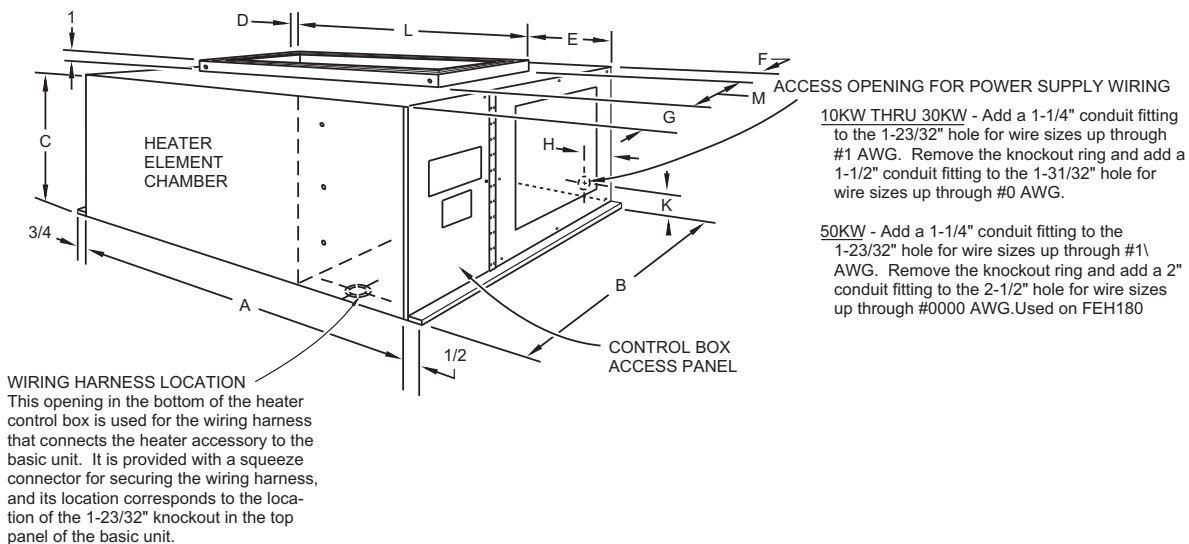

**FIGURE 6 - HEATER DIMENSIONS**

**TABLE 7: HEATER DIMENSIONS**

Heater Model <sup>1</sup>	Nom. kW	Heater dimensions (inches)											
		A	B	C	D	E	F	G	H	K	L	M	
2HB/2HC04501025, 46	10												
2HB/2HC04502025, 46	20	27-1/4	25-1/4	14-1/4	1	4	1/2	5-1/2	1-1/2	1-1/2	22-1/4	19-1/4	
2HB/2HC04503025, 46	30												
2HB04505025, 46	50	29-7/8	26-3/8	21-3/4	2-3/8	5-1/4	3/4	6-3/4	2-1/4	2-1/2	22-1/4	19-1/4	

<sup>1</sup> 2HC04501025, 46 and 2HC04502025 and 46 are used on the 240 units only. The dimensions are the same as shown above for the 2HB heaters. The 2HB heaters are installed on the drive side of the 240 and the 2HC heaters are installed on opposite ends.

