

ACCESSORY KIT INSTALLATION INSTRUCTIONS

Anti-Recycle Timer Accessory Model 2TD08700424
For Single Package R-410A Electric/Electric Air Conditioners Models NM / NL 024 - 060

GENERAL

The solid state timer accessory provides a 5-minute time delay to prevent rapid compressor recycling. The lockout delay sequence begins when the thermostat contacts open thus allowing for optimum control performance of the system.

Enclosed in this kit are one timer control (per Figure 1), wires, screws and tywraps required for proper installation in the unit control box.

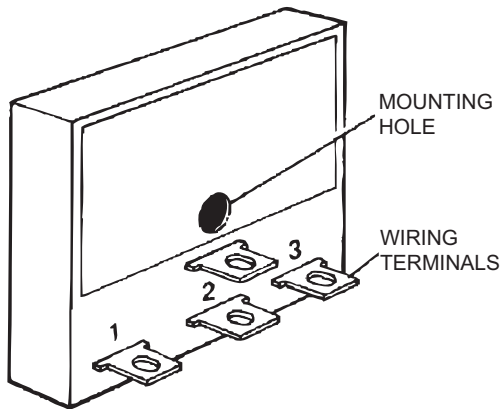

Figure 1: TIMER CONTROL

INSTALLATION

Install the timer accessory as follows:

1. Disconnect all electrical power to the unit.
2. Remove the units control box access panel.
3. Secure the timer control (designated ASCT on the unit wiring diagram) to the inside of the control box using the screw provided. (Pre-punched holes are provided in the control box for mounting.) Refer to the unit wiring diagram for location.

4. Connect wiring to the timer control per the following procedure. Refer to Figure 2 for interconnecting timer wiring.

NOTE: Refer to the unit wiring label inside of the control box access panel to assist in proper identification of wires to be altered. Wires are numbered and/or color coded.

5. Remove wires 228/YEL and 232/YEL from contactor coil M1-A and connect to ASCT-3.
6. Connect wire 821/YEL (Supplied with the kit) from ASCT-1 contactor coil M1-A (where wires 228/YEL and 232/YEL were).
7. Connect wire 820/BRN (Supplied with the kit) from ASCT-2 to contactor coil M1-B. Wire 820/BRN has a piggy-back terminal on one end to connect with wire 200/BRN on the contactor coil.
8. Replace the unit control box access panel.
9. Reconnect the Electrical power to the unit.

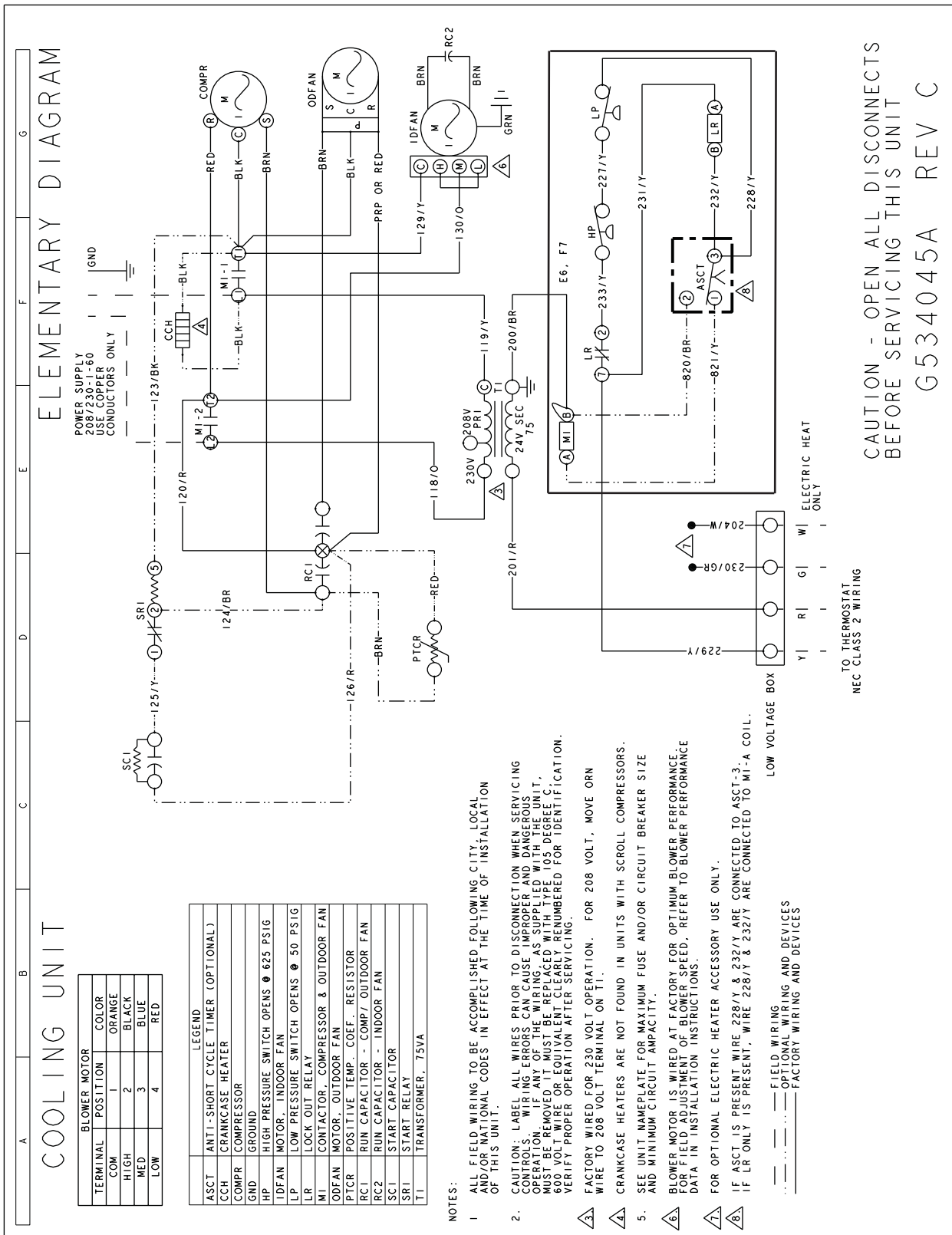

Figure 2: Typical Anti-Recycle Timer Kit Wiring Diagram

Subject to change without notice. Published in U.S.A.
Copyright © 2010 by Johnson Controls Unitary Products. All rights reserved.

557849-UAI-A-0110
Supersedes: Nothing

Johnson Controls Unitary Products
5005 York Drive
Norman, OK 73069