

SUBMITTAL DATA SHEET

**R-410A HORIZONTAL DISCHARGE AIR CONDITIONERS
2.5 THRU 5 TONS
MODELS: 13 SEER TCHD30* THRU 60 - 3 PHASE**

JOB NAME:		LOCATION:		
PURCHASER:		ORDER NO:		
ENGINEER:				
SUBMITTED TO:	FOR:	REF:	APPROVAL:	CONSTRUCTION:
SUBMITTED BY:		DATE:		
UNIT DESIGNATION:		SCHEDULE NO.	MODEL NO.	

PRODUCT DATA

Cooling Performance

Total Capacity _____ MBH
Outdoor Design Temp _____ °F

Electrical Data

Power Supply _____ / _____ / _____
Compressor Ampacity _____ AMPs
Total Unit Ampacity _____ AMPs
Power Input Req _____ KW
Minimum Wire Size _____ AWG
Overcurrent Device
 Fuses Circuit Breaker

Unit Weight

Unit Weight _____ LBS

DIMENSIONS - INCHES

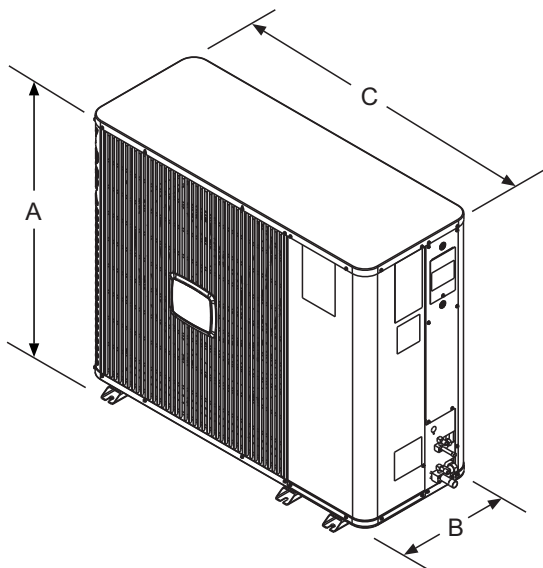

All dimensions are in inches. They are subject to change without notice. Certified dimensions will be provided upon request.

Unit Model	Dimensions (Inches)			Refrigerant Connection Service Valve Size	
	A ¹	B	C	Liquid	Vapor
30	37-1/8	17-1/8	44-5/8	3/8"	3/4"
36	37-1/8	17-1/8	44-5/8		
48	43-1/8	17-1/8	44-5/8		
60	43-1/8	17-1/8	44-5/8		7/8"

1. Including Fan Guard.



FEATURES

- UL approval (units & accessories)
- CUL listed.
- Certified in accordance with the Unitary Small Equipment certification program, under ARI Standard 210/240.
- 1-year limited parts warranty.
- 5-year limited warranty on the compressor.
- All aluminum coil
- Internally protected compressor.
- High pressure switch
- Low pressure switch
- Crankcase heater
- Swept wing fan.
- Durable construction.
- Post-painted steel cabinet.
- Factory wired.
- Sweat refrigerant connections.
- Re-useable brass service valves.
- Easy access to electrical compartment.
- Liquid line filter dryer.
- Powder coated fan guard and coil guard.
- 18 gauge G90 galvanized formed base pan.

CLEARANCES

Service Access	18 Inches
All Other Sides	6 Inches

MATCHING AIR SIDE EQUIPMENT

Model No. _____
Submittal Form No. _____

FIELD INSTALLED ACCESSORIES

Off Cycle Timer (2TD08700124) _____
Thermostats _____
Blower Off Delay (2FD06700224) _____
Low Ambient Pressure Switch
(S1-2LA06700424) _____
Stacking Kit _____

NOTES:
