

SUSPENSION MOUNTING (Horizontal Application)

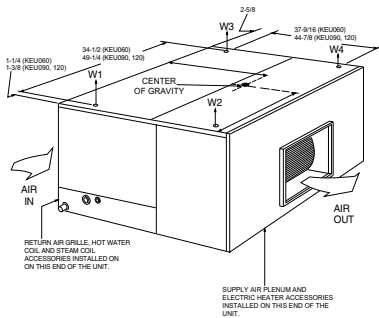

Four 3/8" - 16 weld nuts are provided in the unit support angles for ceiling suspension. Knockouts are provided in panels for access to these weld nuts. Support rods must be supplied in the field.

SUSPENSION WEIGHTS, LBS.			
A	B	C	D

FIELD-INSTALLED ACCESSORIES

- SUPPLY AIR PLENUM (1SP0451)
- RETURN AIR GRILLE (1RG0451)
- BASE (1BS0451)
(Vertical Application Only)
- ELECTRIC HEATER*
Model Number _____
Capacity (@ _____ Volts) _____ MBH
Power Input Requirement _____ KW
(Less Blower Motor)

- STEAM COIL (1NF0451)
Steam Pressure _____ PSIG
Capacity _____ MBH
Steam Rate _____ LBS/HR
Entering Air Temperature _____ °F
- HOT WATER COIL (1HW0451)
Capacity _____ MBH
Entering Water Temperature _____ °F
Water Flow Rate _____ GPM
Entering Air Temperature _____ °F
Water Pressure Drop _____ PSI

* Units with electric heat have a single source power supply. Refer to PRODUCT DATA on front side for electrical data.

ACCESSORY DIMENSIONS – INCHES

ELECTRIC HEATER

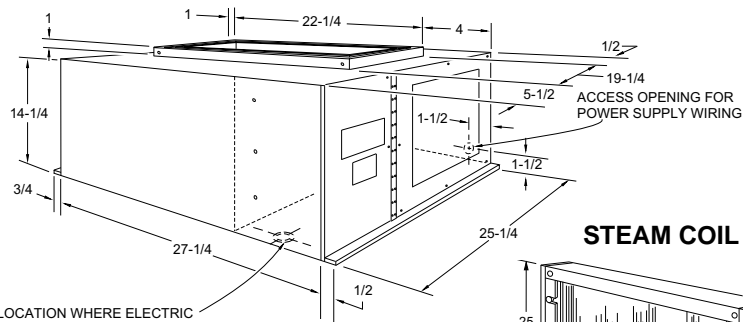

LOCATION WHERE ELECTRIC HEAT WIRING HARNESS PENETRATES THE CABINET OF THE BLOWER UNIT

SUPPLY AIR PLENUM

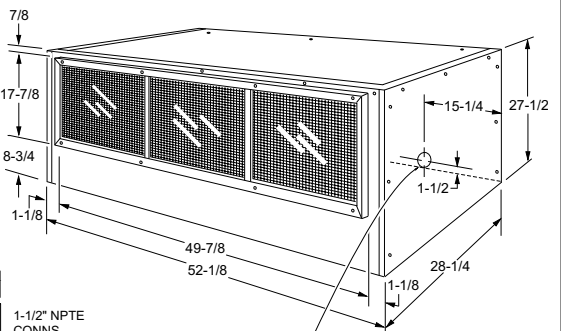

2-1/2" KNOCKOUT FOR POWER WIRING WHEN ELECTRIC HEATER IS USED

STEAM COIL

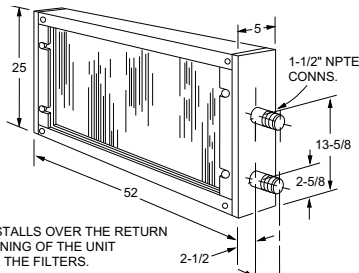

COIL INSTALLS OVER THE RETURN AIR OPENING OF THE UNIT BEFORE THE FILTERS.

BASE

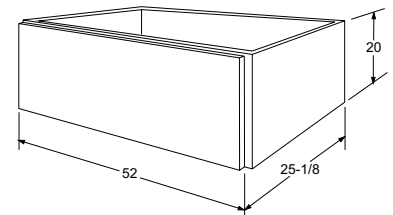

RETURN AIR GRILLE

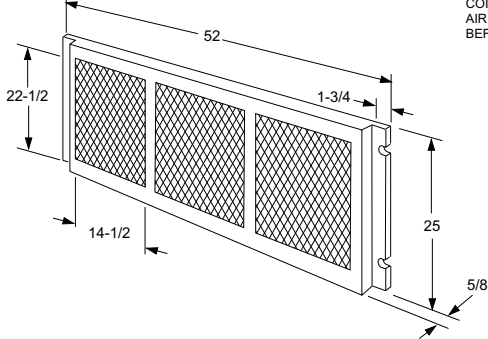

HOT WATER COIL

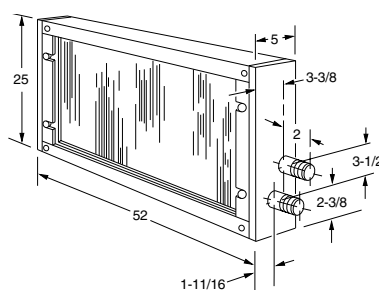

NOTES:
