

JOB NAME _____ LOCATION _____
PURCHASER _____ ORDER NO. _____
ENGINEER _____
SUBMITTED TO _____ FOR: Reference Approval Construction
SUBMITTED BY _____ DATE _____

UNIT DESIGNATION: Schedule No. _____ MODEL NO. _____

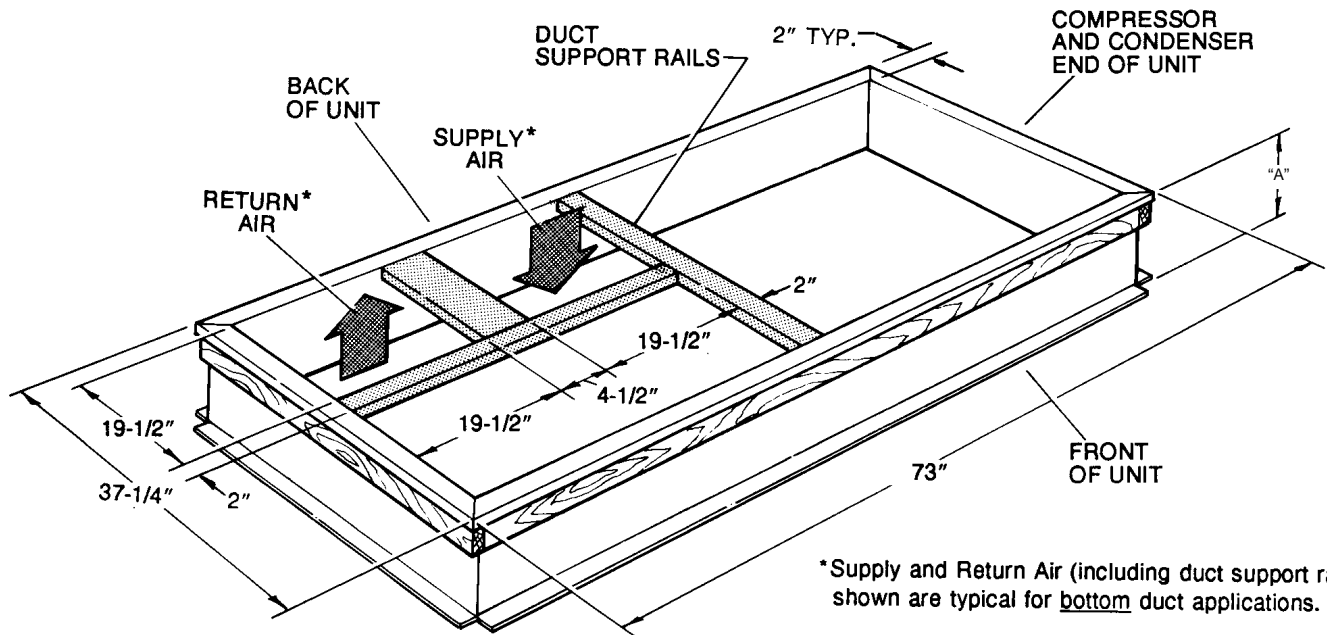

*Supply and Return Air (including duct support rails) shown are typical for bottom duct applications.

For location of horizontal duct applications (on back of unit), refer to Unit Dimension details.

DUCT SIZE:
Supply Air = 19" x 19"
Return Air = 19" x 19"

MODEL	DIMENSION "A"
1RC0465	8"
1RC0434	14"

- NOTE:
1. Roof curb is built to NRCA standards.
 2. Roof curb is constructed of 18 gauge G90 steel.
 3. Unit duct supports are provided.
 4. Full perimeter 4 wood nailer.
 5. Curbs are shipped unassembled.
 6. Corner hinge pins are used for assembly.

Suggested roof opening; 43 1/2" long x 33 1/4" wide.

Refer to price pages for other details.

Subject to change without notice. Printed in the U. S. A.

ROOF CURB
MODELS: 1RC0434 AND 1RC0465
(FOR 3 THRU 6 TON SINGLE PACKAGE ROOFTOP MODELS)

FORM 530.22-SD10L (297)
Supersedes: Nothing

