

INSTALLATION INSTRUCTION

POWER EXHAUST KIT MODEL 2PE04703025 AND 2PE04703046

Supersedes: Nothing

530.18-N1.10V (997)

FOR 3 THRU 6 TON SINGLE PACKAGE EQUIPMENT AND SUNLINE SERIES GAS/ELECTRIC AND COOLING AIR CONDITIONERS AND HEAT Pumps (for down or side applications)

035-15567



DANGER: High voltage and moving parts around motors and motor driven equipment can cause serious or fatal injuries. Always disconnect power source before working on power exhaust unit or its connected equipment. Installation must conform to all OSHA requirements, The National Electrical Code (NEC) and all local codes.

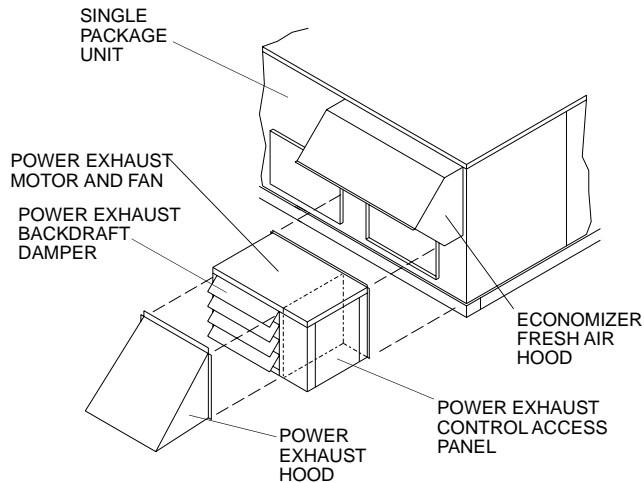

SCOPE

These instructions cover all the necessary information to properly field install Power Exhaust Kits model numbers 2PE04703025 (208/230-1-60 volt) and 2PE04703046 (460-1-60 volt) on single package rooftop air conditioners or heat pumps, in cooling capacities from 36 through 72 Mbt (3 thru 6 ton). These kits are wired for single phase applications, however, they are compatible with three phase applications. See Figures 7 and 8.

These power exhaust kits are normally used concurrently with economizers, however, economizers are not required for operation. Stale air is removed from a building or the building is depressurized via the return air duct and is controlled by the rooftop equipment and/or accessories. See Figure 9 for dimensions.

INITIAL INSPECTION AND HANDLING

After opening carton or crate, look for concealed damage. If concealed damage is found, immediately file claim with carrier.

INSTALLATION

1. Disconnect power from rooftop unit.
2. Remove the rooftop unit's filter access panel.
3. If attaching the power exhaust accessory directly to the rooftop unit for downshot applications, remove the rooftop unit's horizontal return air duct cover and discard. If attaching to the horizontal return air duct, for side supply/return applications, cut a hole to fit the opening of the power exhaust unit.
4. Connect harness leads of power exhaust accessory to independent power supply. (The unit is wired for 230 volts. It can be converted to 208 volts by removing the orange wire from the transformer to the relay and replacing it with the red wire from the transformer).
5. Ground unit with a suitable ground connection either through unit supply wiring or an earth ground.
6. Position low voltage end switch on economizer damper motor so that it will activate the power exhaust at the desired

setting. Refer to "Installation of End Switch" for mounting. If used without economizer run low voltage wire to coil of blower contact. Place these wires in parallel with this coil.

7. Attach power exhaust unit to opening with sheet metal screws to secure into place.
8. Replace the filter access panel onto the rooftop unit and secure.
9. Clean up once unit is operating properly, caulk any open joints, holes or seams to make the unit completely air and water tight.

MAINTENANCE



DANGER: Before performing any maintenance, disconnect power and allow motor(s) to come to a complete stop. Discharge capacitors, if any, for safety.

All motors use sealed bearings; no lubrication is necessary.

Make visual inspection of dampers; linkage assemblies; fan blades or blower wheels and motors. Check for dirt accumulations; unusual noises or vibrations; overheating; sheaves and belts; high motor current; poor wiring or overheated connections; loose mounting bolts and worn relay contacts.

INSTALLATION OF END SWITCH

1. Determine the crank arm stroke range (See Fig. 1) by running the actuator through one complete cycle. Mount the end switch on the side opposite of the crank arm stroke range.

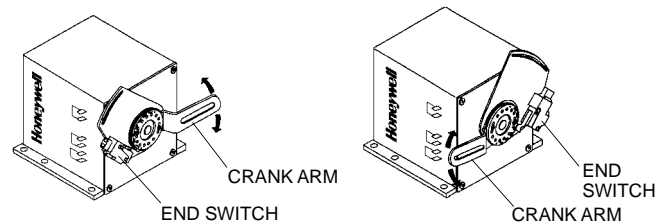

FIGURE 1 - CRANK ARM STROKE RANGE

2. Disconnect power to the actuator and the device to be controlled by the end switch.
3. Assemble the end switch and plastic insulating boot (See Fig. 2). Attach the end switch and plastic insulating boot to the switch mounting plate with the two #4-40 screws, two washers and two lock washers provided with the end switch assembly.

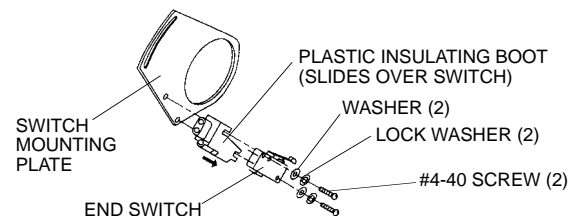

FIGURE 2 - END SWITCH AND INSULATING BOOT ASSEMBLY

NOTE: The #4-40 screws provided with the end switch assembly are sized to allow the switch mounting plate to mount flush against the actuator side panel.

4. Mark the actuator crank arm position on the actuator panel with a pencil, pen or tape.
5. Remove the actuator crank arm.
6. Based on the determination of the crank arm stroke range in Step 1 above, remove the screw from the upper actuator corner where the switch mounting plate is to be assembled. (See Fig. 1)
7. Place the switch mounting plate over the actuator drive spindle and fasten it in place with the actuator corner screw from Step 6 (See Fig. 3). Center the screw in the switch mounting plate slot.

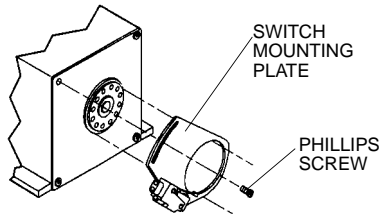

FIGURE 3 - SWITCH MOUNTING PLATE LOCATION

8. Place the actuator crank arm over the switch mounting plate, aligning the crank arm with the placement marks from Step 4.
9. Determine at which point in the actuator crank arm rotation the end switch should close. Install the circular switch cam over the actuator crank arm, positioning one of the small reference holes in the circular switch cam at the end switch close point on the actuator crank arm (See Fig. 4). The two small holes in the circular switch cam are references for the make/break point of the end switch. The portion of the circular switch cam shown with a dotted line in Fig. 4 identifies the cam area that will close the end switch when the actuator crank arm rotates.

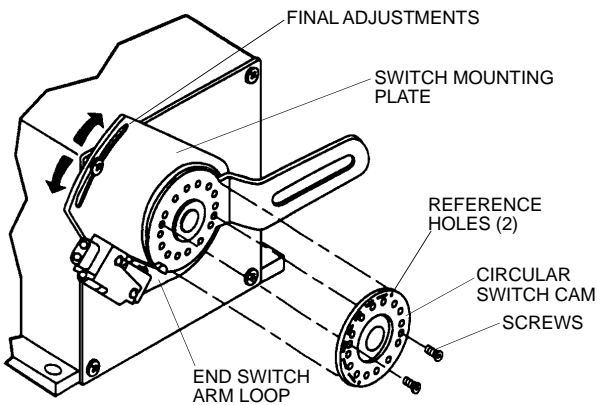

FIGURE 4 - CIRCULAR SWITCH CAM

NOTE: Two small protrusions on the bottom of the circular switch cam fit into holes on the actuator crank arm to position the cam.

10. Bend the metal arm on the end switch arm loop (if necessary) by using a small screwdriver blade to adjust the end switch open and close points on each side of the reference hole (See Fig. 5).

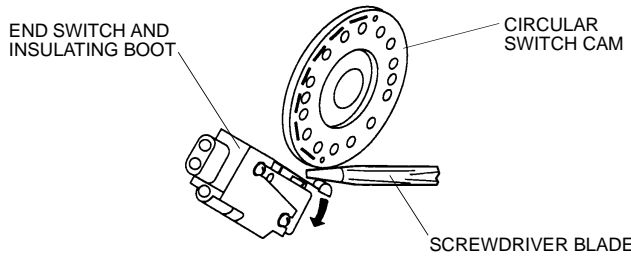

FIGURE 5 - END SWITCH ARM LOOP ADJUSTMENT

ADJUSTMENT

If a finer adjustment is necessary, loosen the screw holding the switch mounting plate on the actuator and move the switch mounting plate to correctly place the end switch arm loop on the circular switch cam. Carefully tighten the Phillips screw. Do not over torque the screw to prevent stripping the actuator plastic case threads.

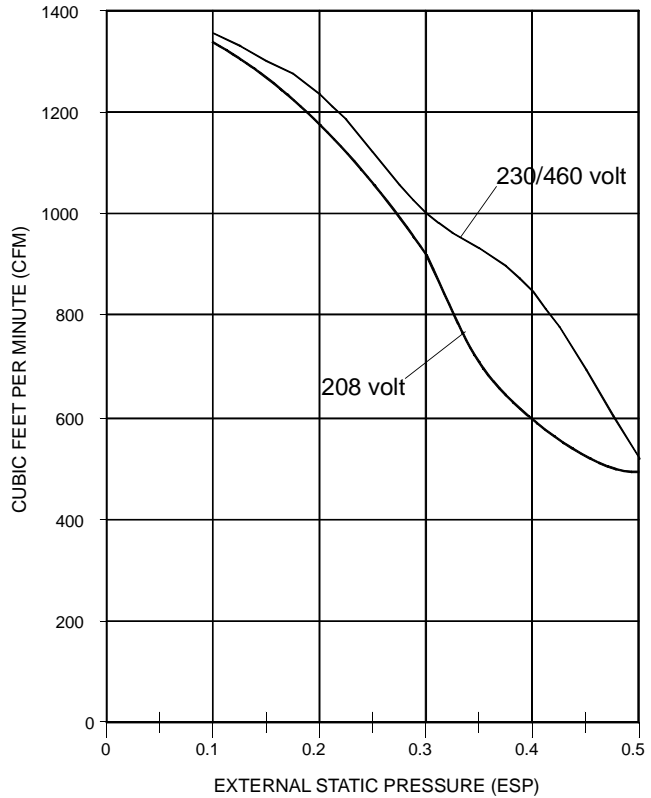

FIGURE 6 - EXTERNAL STATIC PRESSURE VS CFM PERFORMANCE

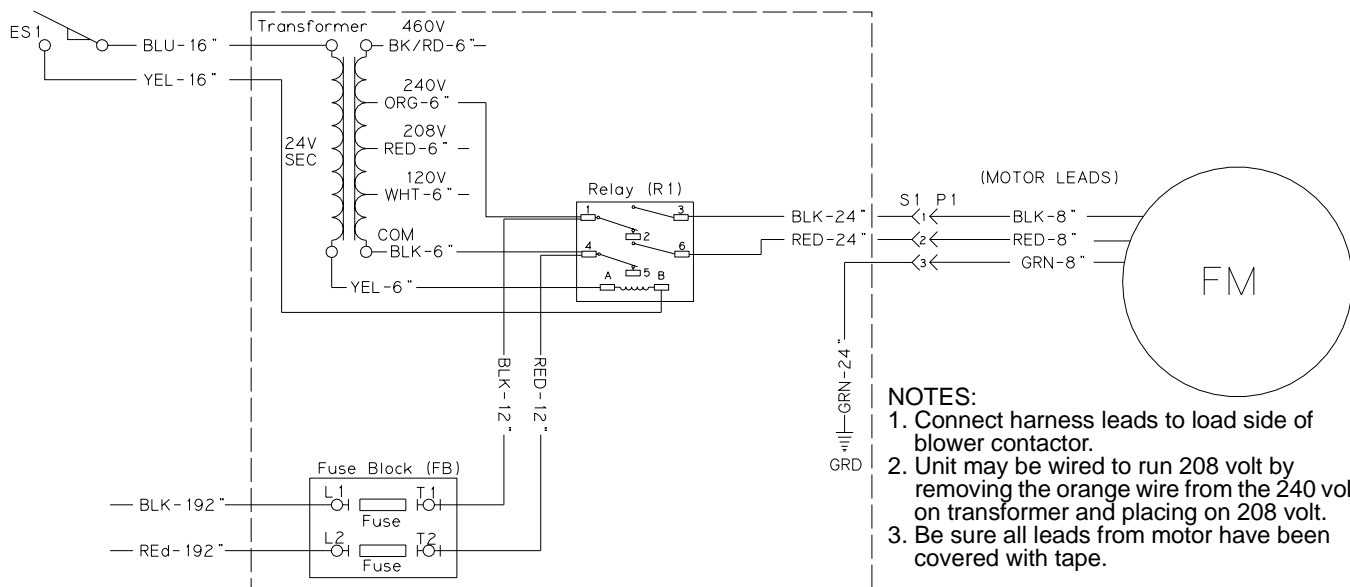

FIGURE 7 - WIRING DIAGRAM (208/230-1-60)

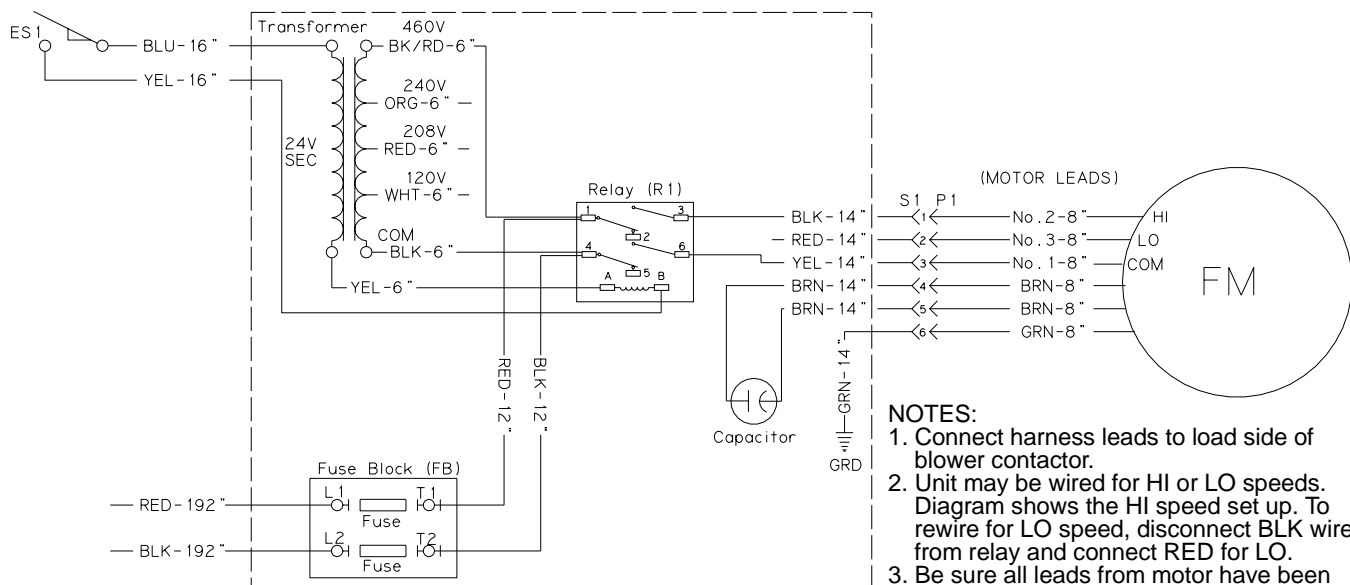

FIGURE 8 - WIRING DIAGRAM (460-1-60)

LEGEND:
 ES1 End Switch
 FB Fuse Block
 FM Fan Motor
 GRD Ground
 P1 Fan Plug Male
 R1 Relay
 S1 Control Box Female

TABLE 1 - ELECTRICAL DATA

MODEL	VOLTAGE	MOTOR			UNIT			
		HP	RPM	QTY/TYPE	LRA	FLA	MCA	FUSE SIZE
2PE04703025	208/230-1-60	0.5	1725	1 / direct dive	23.7	4.4	5.5	8
2PE04703046	460-1-60	0.5	1725	1 / direct dive	4.1	1.7	2.1	5

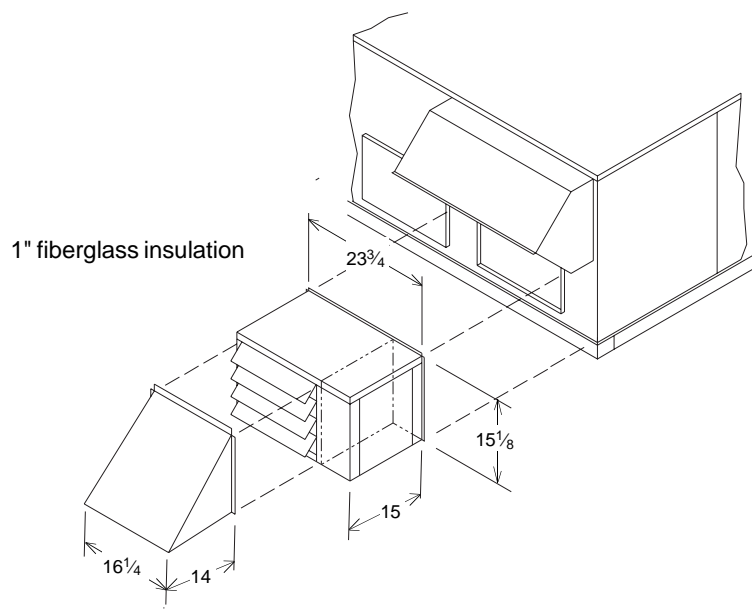

FIGURE 9 - POWER EXHAUST ACCESSORY DIMENSIONS (inches)