

SUBMITTAL DATA SHEET



ACCLIMATE
R-410A SPLIT SYSTEM HEAT PUMP UNITS
18 SEER 2, 3, 4 & 5 TON
MODELS: HL8B 024 THRU 060

JOB NAME:			LOCATION:		
PURCHASER:			ORDER NO:		
ENGINEER:					
SUBMITTED TO:		FOR:	REF:	APPROVAL:	CONSTRUCTION:
SUBMITTED BY:			DATE:		
UNIT DESIGNATION:			SCHEDULE NO.		MODEL NO.

PRODUCT DATA

Cooling Performance

Total Capacity _____ MBH
 Outdoor Design Temp _____ °F

Electrical Data

Power Supply ___ / ___ / ___
 Compressor Ampacity _____ AMPs
 Total Unit Ampacity _____ AMPs
 Power Input Req _____ KW
 Minimum Wire Size _____ AWG
 Overcurrent Device
 Fuses Circuit Breaker

Unit Weight

Unit Weight _____ LBS

DIMENSIONS - INCHES

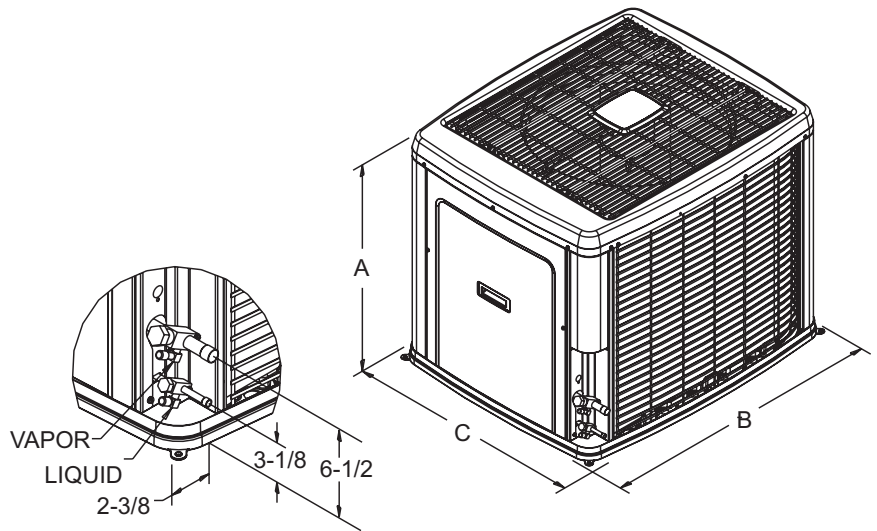

All dimensions are in inches. They are subject to change without notice. Certified dimensions will be provided upon request.

Unit Model	Dimensions (Inches)			Refrigerant Connection Service Valve Size	
	A	B	C	Liquid	Vapor
024	39-1/2	42	34	3/8"	3/4"
036	39-1/2	42	34		
048	39-1/2	42	34		
060	39-1/2	42	34		7/8"



FEATURES

- UL approval (units & accessories)
- CSA listed and ARI certified
- Copper tube/aluminum fin coil
- Hi and Lo pressure switches standard
- Durable construction
- Powder-painted steel cabinet
- Factory wired
- R-410A total system charge (thru 15 ft. of lines)
- Sweat refrigerant connections
- Re-usable service valves
- Slide down electrical compartment for easy access
- Enhanced coil guard
- Composite base pan
- Isolated compressor compartment
- Full service access panel
- Comfort alert compressor protection
- Full service access panel
- Comfort alert compressor protection
- SilentDrive™ system
- Swept wing fan design
- 5-year limited parts warranty
- 10-year limited warranty on the compressor
- Premium system warranty* - Limited Lifetime Compressor Warranty, 10 year parts warranty

* Must be matched with an approved Luxaire, coil and/or Air Handler, otherwise reverts to 10 year compressor warranty and 5 year parts warranty.

MATCHING AIR SIDE EQUIPMENT

Model No. (_____)

Submittal Form No. (_____)

FIELD INSTALLED ACCESSORIES

Dehumidification Control (2HU16700124) (_____)

Thermostat (_____)

Thermal Expansion Valve* (_____)

Low Ambient Pressure Switch Kit (_____)

Hard Start Kit (_____)

* Must be installed for proper performance.

(Refer to Technical Guide for detailed specifications on the unit and its accessories.)

CLEARANCES

Front of Unit..... 18 inch

All Other Sides..... 24 inch

Above Unit..... 48 inch

Below Unit..... 0 inch

*Must be installed for proper performance.

NOTES:
