

# SUBMITTAL DATA SHEET



**ACCLIMATE**  
**R-410A SPLIT SYSTEM AIR CONDITIONER UNITS**  
**15 SEER 2, 3, 4 & 5 TON**  
**MODELS: AL5B024 THRU 060**

JOB NAME:			LOCATION:		
PURCHASER:			ORDER NO.:		
ENGINEER:					
SUBMITTED TO:		FOR:	REF:	APPROVAL:	CONSTRUCTION:
SUBMITTED BY:			DATE:		
UNIT DESIGNATION:		SCHEDULE NO.:		MODEL NO.:	

## PRODUCT DATA

### Cooling Performance

Total Capacity \_\_\_\_\_ MBH  
 Outdoor Design Temp \_\_\_\_\_ °F

### Electrical Data

Power Supply \_\_\_\_ / \_\_\_\_ / \_\_\_\_  
 Total Unit Ampacity \_\_\_\_\_ AMPs  
 Power Input Req \_\_\_\_\_ KW  
 Minimum Wire Size \_\_\_\_\_ AWG  
 Maximum Overcurrent Device  
 Fuses    Circuit Breaker

### Unit Weight

Unit Weight \_\_\_\_\_ LBS

## DIMENSIONS - INCHES

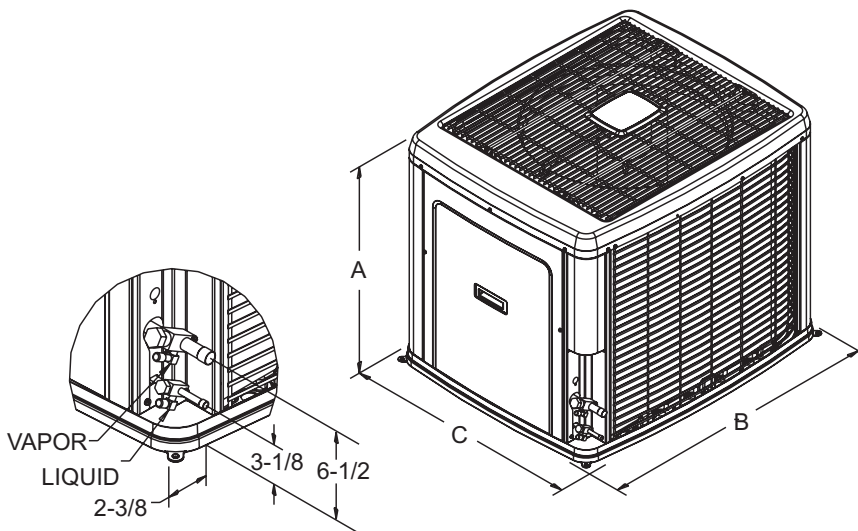

All dimensions are in inches. They are subject to change without notice. Certified dimensions will be provided upon request.

Unit Model	Dimensions (Inches)			Refrigerant Connection Service Valve Size	
	A	B	C	Liquid	Vapor
024	33-1/2	37	31	3/8"	3/4"
036	39-1/2	37	31		7/8"
048	39-1/2	37	31		7/8"
060	39-1/2	37	31		7/8" *

\* Expander fitting required for 1-1/8" line set.



**FEATURES**

- UL approval (units & accessories)
  - CSA listed and ARI certified
  - 5-year limited parts warranty
  - 10-year limited warranty on the compressor
  - Copper tube/aluminum fin coil
  - Hi and Lo pressure switches standard
  - Durable construction
  - Powder-painted steel cabinet
  - Factory wired
  - R-410A total system charge (thru 15 ft. of lines)
  - Sweat refrigerant connections
  - Re-usable service valves
  - Slide down electrical compartment for easy access
  - Enhanced coil guard
  - Composite base pan
  - Isolated compressor compartment
  - Full service access panel
  - Comfort alert compressor protection
  - Silentdrive system
  - Swept wing fan design
  - Premium system warranty\* - Limited Lifetime Compressor Warranty, 10 year parts warranty
- \* Must be matched with an approved Luxaire, coil and/or Air Handler.

**MATCHING AIR SIDE EQUIPMENT**

Model No. ( \_\_\_\_\_ )  
 Submittal Form No. ( \_\_\_\_\_ )

**FIELD INSTALLED ACCESSORIES**

Dehumidification Control (2HU16700124) ( \_\_\_\_\_ )  
 Thermostat ( \_\_\_\_\_ )  
 Thermal Expansion Valve\* ( \_\_\_\_\_ )  
 Hard Start Kit ( \_\_\_\_\_ )

*(Refer to Technical Guide for detailed specifications on the unit and its accessories.)*

**CLEARANCES**

Front of Unit..... 24 inch  
 All Other Sides..... 12 inch  
 Above Unit ..... 60 inch  
 Below Unit..... 0 inch

\*Must be installed for proper performance.

**NOTES:**

---



---



---