

SUBMITTAL DATA SHEET

**GAS/ELECTRIC & ELECTRIC/ELECTRIC
SINGLE PACKAGE AIR CONDITIONERS
MODELS: DW-03, -04 & -05**



JOB NAME:		LOCATION:		
PURCHASER:		ORDER NO:		
ENGINEER:				
SUBMITTED TO:	FOR:	REF:	APPROVAL:	CONSTRUCTION:
SUBMITTED BY:		DATE:		
UNIT DESIGNATION:		SCHEDULE NO.	MODEL NO.	

COOLING PERFORMANCE

TOTAL CAPACITY----- MBH
 SENSIBLE CAPACITY----- MBH
 OUTDOOR DESIGN TMP. _____ °F DB/WB
 TOTAL SUPPLY AIR ----- CFM
 TEMP. OF AIR ENTERING
 EVAPORATOR COIL ----- °F
 POWER INPUT REQ. ----- KW
 (LESS BLOWER MOTOR)

HEATING PERFORMANCE

ELECTRIC HEAT----- KW
 GAS-FIRED INPUT-CAP. ----- MBH

SUPPLY AIR BLOWER PERFORMANCE

TOTAL SUPPLY AIR ----- CFM
 EXT. STATIC PRESS. ----- IWG
 BLOWER SPEED----- RPM
 POWER OUTPUT REQ. ----- BHP
 MOTOR RATING ----- HP
 POWER INPUT REQ. ----- KW

ELECTRICAL DATA

POWER SUPPLY-----
 TOTAL UNIT AMPACITY ----- AMPS
 MAX. OVERCURRENT DEVICE
 ___ FUSE ___ BREAKER ----- AMPS

TOTAL UNIT WEIGHT

INCLUDING FACTORY- INSTALLED
 OPTIONS----- LBS

FACTORY INSTALLED OPTIONS

- SINGLE INPUT ELECTRONIC ENTHALPY ECONOMIZERS -----
- MOTORIZED OUTDOOR AIR INTAKE DAMPER -----
- PHENOLIC COATED EVAPORATOR COILS-----
- PHENOLIC COATED CONDENSER COILS -----
- ELECTRIC HEATERS -----
- FILTER (2" PLEATED)-----
- POWERED CONVENIENCE OUTLET-----
- NON-POWERED CONVENIENCE OUTLET -----
- DISCONNECT SWITCH-----
- BAS - (BUILDING AUTOMATION SYSTEMS) -----
- Simplicity® Intelli-Comfort™ -----
- Honeywell™ -----
- Novar®-----
- Johnson -----
- CPC -----
- SMOKE DETECTOR (RETURN)- -----
- SMOKE DETECTOR (SUPPLY) -----
- COIL GUARD -----
- STAINLESS STEEL HEAT EXCHANGER -----
- STAINLESS STEEL DRAIN PAN -----
- BAS READY ECONOMIZER (2-10 V.D.C. ACTUATOR WITHOUT
A CONTROLLER) -----
- AIR PROVING SWITCH-----
- PHASE MONITOR-----
- BELT DRIVE -----
- BELT DRIVE (HIGH STATIC) -----
- DIRECT DRIVE -----
- DIRTY FILTER SWITCH -----
- HINGED FILTER DOOR/"TOOLLESS" BLOWER AND
ACCESS PANELS (NOT HINGED) -----

FIELD INSTALLED ACCESSORIES

- SINGLE INPUT ELECTRONIC ENTHALPY ECONOMIZERS -----
- ENTHALPY ACCESSORY CONTROL KIT (DUAL)-----
- MOTORIZED OUTDOOR AIR INTAKE DAMPER -----
- ROOF CURBS -----
- HIGH ALTITUDE NATURAL GAS -----
- PROPANE CONVERSION -----
- HIGH ALTITUDE PROPANE -----
- BAROMETRIC RELIEF DAMPER -----
- BURGLAR BARS-----
- FLUE EXHAUST EXTENSION KIT -----
- CO2 SENSOR, UNIT MOUNT -----
- CO2 SENSOR, SPACE MOUNT -----
- DIRTY FILTER SWITCH -----
- AIR PROVING SWITCH-----
- POWER EXHAUST -----
- ELECTRIC HEAT -----
- LOW NOx KIT -----
- COIL GUARDS -----
- HAIL GUARDS -----
- LOW AMBIENT KIT -----
- GAS PIPING KIT -----
- WALL MOUNT TEMPERATURE SENSOR (Intelli-Comfort™) -----
- WALL MOUNT TEMPERATURE SENSOR WITH
OVERRIDE (Intelli-Comfort™) -----
- WALL MOUNT TEMPERATURE SENSOR WITH
OVERRIDE & SET POINT ADJ. (Intelli-Comfort™)- -----
- HUMIDITY SENSOR (Intelli-Comfort™)-----

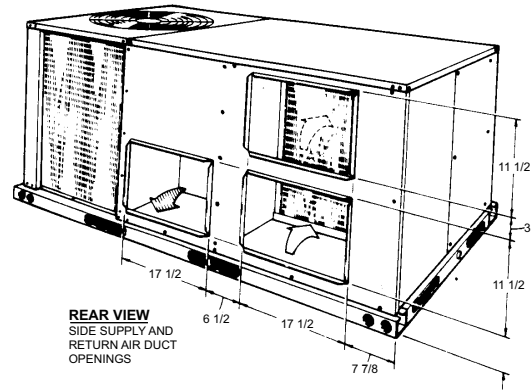
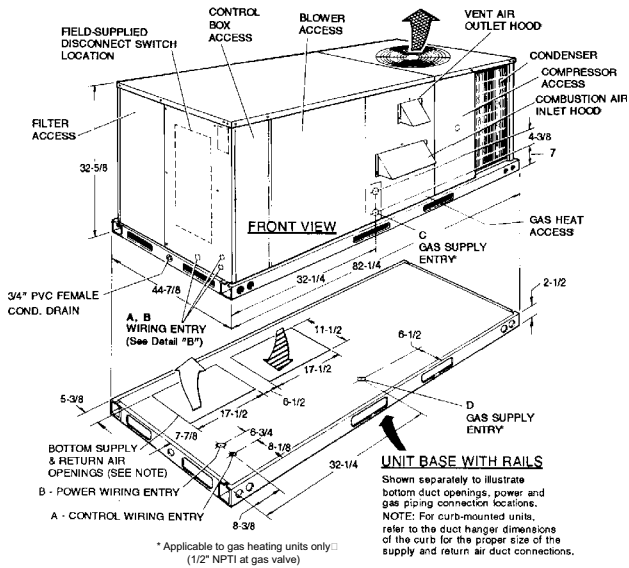

UTILITIES ENTRY DATA

HOLE	KNOCKOUT SIZE (DIA.)	USED FOR
A	7/8"	Control Wiring (Side or Bottom)
B	2"	Power Wiring (Side or Bottom)
C	1-5/8"	Gas Piping (Front)
D	1-1/2"	Gas Piping (Bottom)

UNIT BASE WITH RAILS
 Shown separately to illustrate bottom duct openings, power and gas piping connection locations.
 NOTE: For curb-mounted units, refer to the duct hanger dimensions of the curb for the proper size of the supply and return air duct connections.

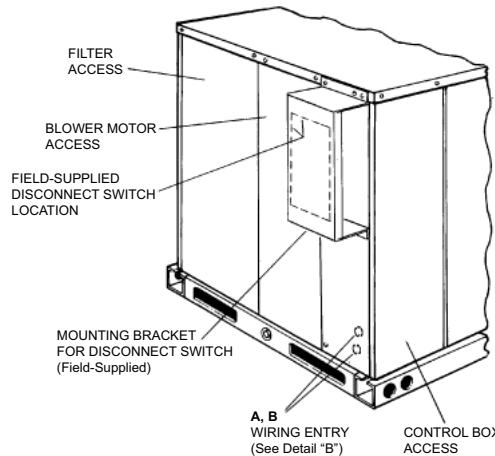

DISCONNECT SWITCH LOCATION AND MOTOR ACCESS PANEL FOR UNIT WITH "BELT-DRIVE" OPTION

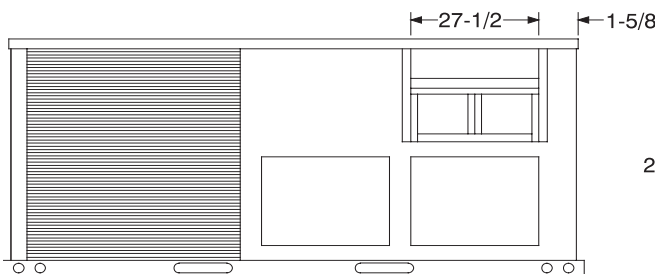

REAR VIEW

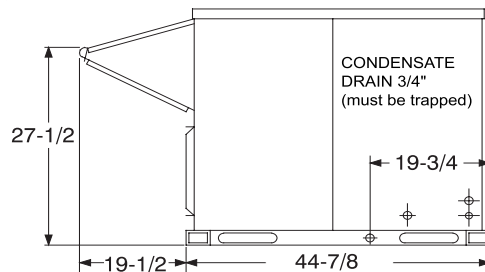

L.H. END VIEW

**DETAIL "A"
 UNIT WITH ECONOMIZER RAINHOOD**

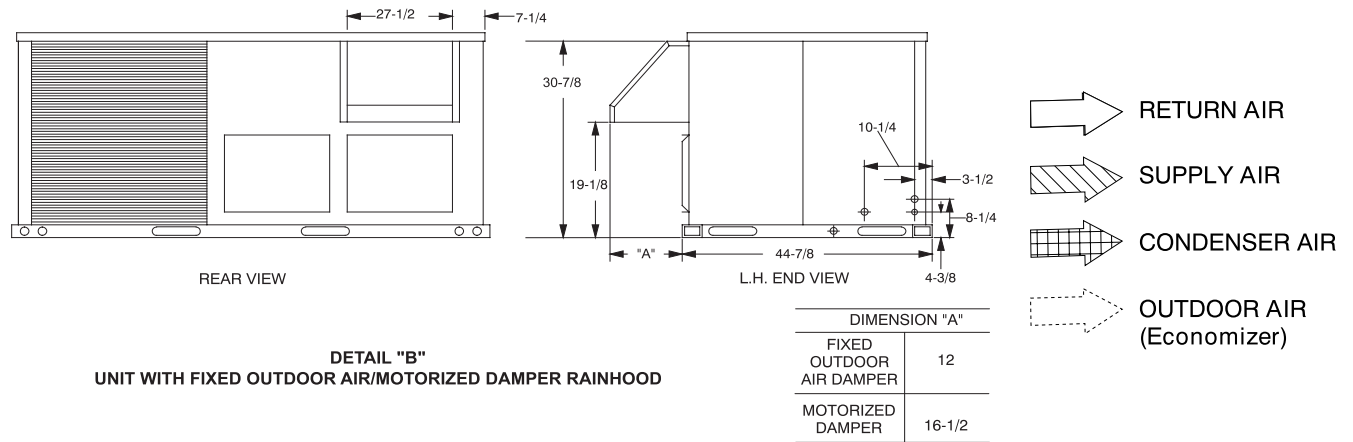

MINIMUM CLEARANCES

LOCATION	CLEARANCE
Front	24" (Cooling/Electric Heat) 32" (Gas Heat)
Rear	12" (Less Economizer) 36" (With Economizer or Fixed Air/Motorized Damper)
Left Side (Filter Access)	24" (Less Economizer) 36" (With Economizer)
Right Side (Cond. Coil)	24"
Below Unit ¹	0"
Above Unit ²	72" (For Condenser Air Discharge)

1. Units may be installed on combustible floors made from wood or class A, B, or C roof covering material.
2. Units must be installed outdoors. Overhanging structures or shrubs should not obstruct condenser air discharge outlet.

NOTE: A 1" clearance must be provided between any combustible material and the supply air ductwork for a distance of 3 feet from the unit.

NOTE: The products of combustion must not be allowed to accumulate within a confined space and recirculate.

NOTE: Locate unit so that the vent air outlet hood is at least:

- Three (3) feet above any force air inlet located within 10 horizontal feet (excluding those integral to the unit).
- Four (4) feet below, four horizontal feet from, or one foot above any door or gravity air inlet into the building.
- Four (4) feet from electric and gas meters, regulators and relief equipment.

NOTE: Units and ductwork are approved for zero clearance to combustible materials when equipped with electric heaters.

NOTE: All entry holes should be field sealed to prevent rain water entry into building.

NOTES

REFER TO THE TECHNICAL GUIDE FOR THE LIST OF STANDARD FEATURES

ATTACHED **NOT ATTACHED**

Subject to change without notice. Printed in U.S.A.
Copyright © 2008 by Johnson Controls, Inc. All rights reserved.

335970-LSD-C-0408
Supersedes: 335970-LSD-B-0507

Johnson Controls Unitary Products
5005 York Drive
Norman, OK 73069