

SUBMITTAL DATA SHEET

**SINGLE PACKAGE HEAT PUMP
MODEL: BA-20**



| | | | | |
|-------------------|------|--------------|-----------|---------------|
| JOB NAME: | | LOCATION: | | |
| PURCHASER: | | ORDER NO: | | |
| ENGINEER: | | | | |
| SUBMITTED TO: | FOR: | REF: | APPROVAL: | CONSTRUCTION: |
| SUBMITTED BY: | | DATE: | | |
| UNIT DESIGNATION: | | SCHEDULE NO. | MODEL NO. | |

COOLING PERFORMANCE

TOTAL CAPACITY ----- MBH

SENSIBLE CAPACITY ----- MBH

OUTDOOR DESIGN TMP. _____ °F DB/WB

TOTAL SUPPLY AIR ----- CFM

TEMP. OF AIR ENTERING

EVAPORATOR COIL ----- °F

POWER INPUT REQ. ----- KW
(LESS BLOWER MOTOR)

HEATING PERFORMANCE

CAPACITY

@ 47°F ----- MBH

@ 17°F ----- MBH

COEFFICIENT OF PERFORMANCE

@ 47°F ----- MBH

@ 17°F ----- MBH

(RESISTANCE HEAT - SEE REVERSE SIDE)

SUPPLY AIR BLOWER PERFORMANCE

TOTAL SUPPLY AIR ----- CFM

EXT. STATIC PRESS. ----- IWG

BLOWER SPEED ----- RPM

POWER OUTPUT REQ. ----- BHP

MOTOR RATING ----- HP

POWER INPUT REQ. ----- KW

ELECTRICAL DATA

POWER SUPPLY -----

TOTAL UNIT AMPACITY ----- AMPS

MAX. OVERCURRENT DEVICE

__ FUSE __ BREAKER ----- AMPS

TOTAL UNIT WEIGHT

INCLUDING FACTORY- INSTALLED
OPTIONS ----- LBS

FACTORY INSTALLED OPTIONS

SINGLE INPUT ELECTRONIC ENTHALPY ECONOMIZERS- - - - -

BAS-READY ECONOMIZER (2-10 V.D.C. ACTUATOR WITHOUT A CONTROLLER) - - - - -

POWER EXHAUST - - - - -

MOTORIZED OUTDOOR AIR INTAKE DAMPER - - - - -

BAROMETRIC RELIEF DAMPER - - - - -

PHENOLIC COATED EVAPORATOR COILS - - - - -

PHENOLIC COATED CONDENSER COILS - - - - -

FILTER (2" THROW AWAY) - - - - -

FILTER (4" PLEATED) - - - - -

POWERED CONVENIENCE OUTLET - - - - -

NON-POWERED CONVENIENCE OUTLET - - - - -

DISCONNECT SWITCH - - - - -

BAS - (BUILDING AUTOMATION SYSTEMS) - - - - -

 Simplicity® Intelli-Comfort™ - - - - -

 Honeywell™ - - - - -

 Novar® - - - - -

 Johnson - - - - -

 CPC - - - - -

SMOKE DETECTOR (RETURN) - - - - -

SMOKE DETECTOR (SUPPLY) - - - - -

STAINLESS STEEL DRAIN PAN - - - - -

COIL GUARD - - - - -

PHASE MONITOR - - - - -

HIGH STATIC DRIVE - - - - -

DIRTY FILTER SWITCH - - - - -

HINGED FILTER DOOR/"TOOL FREE" BLOWER AND ACCESS PANELS (NOT HINGED) - - - - -

HINGED/"TOOL FREE" BLOWER, BLOWER MOTOR, FILTER AND ELECTRICAL ACCESS PANELS - - - - -

ELECTRIC RESISTANCE HEAT¹ - - - - -

 CAPACITY (AT _____ VOLTS) ----- MBH

POWER INPUT REQUIREMENT ----- KW

FIELD-INSTALLED ACCESSORIES

SINGLE INPUT ELECTRONIC ENTHALPY ECONOMIZERS- - - - -

MOTORIZED OUTDOOR AIR INTAKE DAMPER - - - - -

ROOF CURBS - - - - -

SIDE DUCT FLANGES - - - - -

BAROMETRIC RELIEF DAMPER - - - - -

HIGH STATIC DRIVE - - - - -

ENTHALPY ACCESSORY CONTROL KIT (DUAL) - - - - -

BURGLAR BARS - - - - -

WOOD SKID - - - - -

DIRTY FILTER SWITCH - - - - -

AIR PROVING SWITCH - - - - -

CO2 SENSOR - - - - -

COIL GUARD - - - - -

SMOKE DETECTOR (RETURN) - - - - -

SMOKE DETECTOR (SUPPLY) - - - - -

COIL GUARDS - - - - -

HAIL GUARDS - - - - -

WALL MOUNT TEMPERATURE SENSOR (Intelli-Comfort™) - - - - -

WALL MOUNT TEMPERATURE SENSOR WITH OVERRIDE (Intelli-Comfort™) - - - - -

WALL MOUNT TEMPERATURE SENSOR WITH OVERRIDE & SET POINT ADJ. (Intelli-Comfort™) - - - - -

HUMIDITY SENSOR (Intelli-Comfort™) - - - - -

1. UNITS WITH ELECTRIC HEAT HAVE A SINGLE POWER SUPPLY. REFER TO PRODUCT DATA ON THE LEFT SIDE FOR ELECTRICAL DATA.

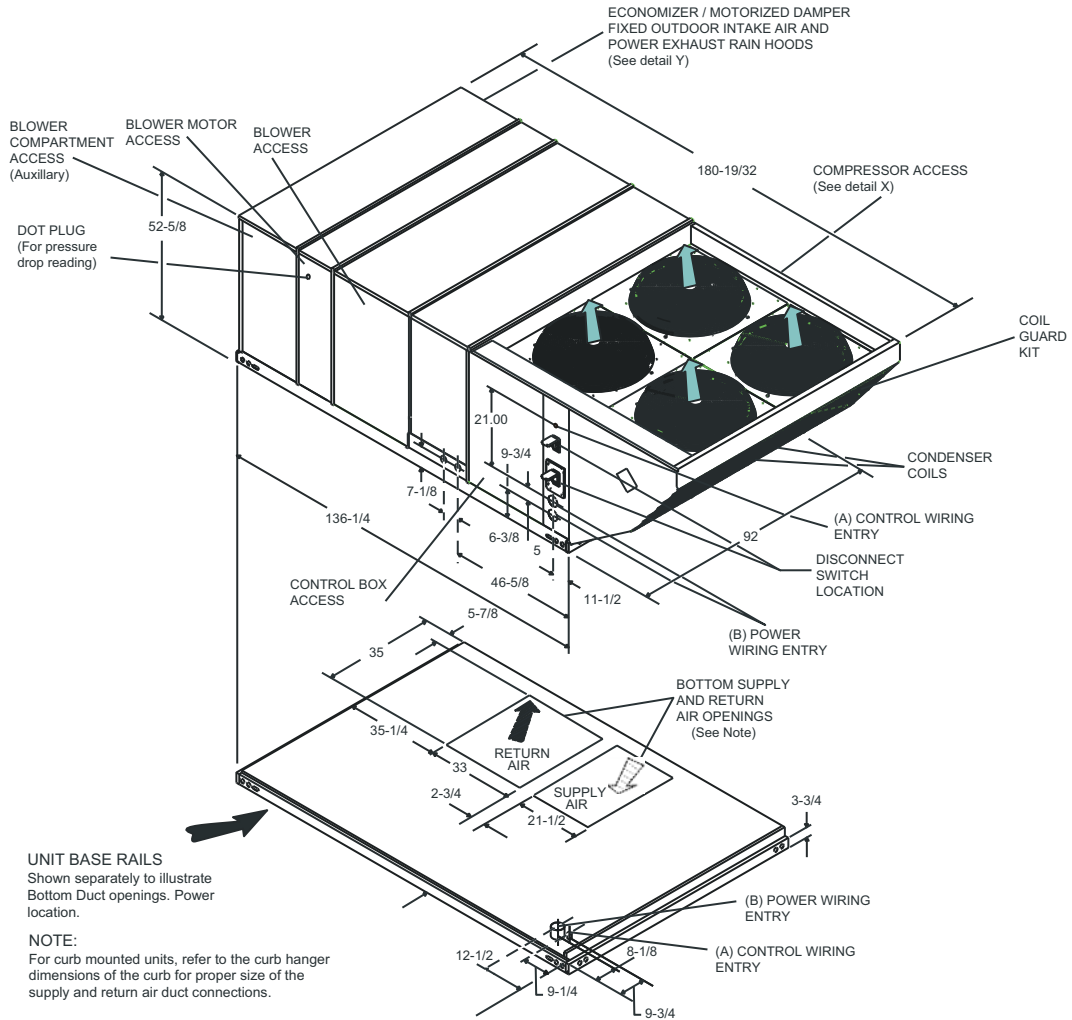

UTILITIES ENTRY DATA

| HOLE | OPENING SIZE (DIA.) | USED FOR | |
|------|---------------------|----------------|--------|
| | | | |
| A | 1-1/8" KO | Control Wiring | Side |
| | 3/4" NPS (Fem.) | | Bottom |
| B | 3-5/8" KO | Power Wiring | Side |
| | 3" NPS (Fem.) | | Bottom |

NOTE: All entry holes should be field sealed to prevent rain water entry into the building.

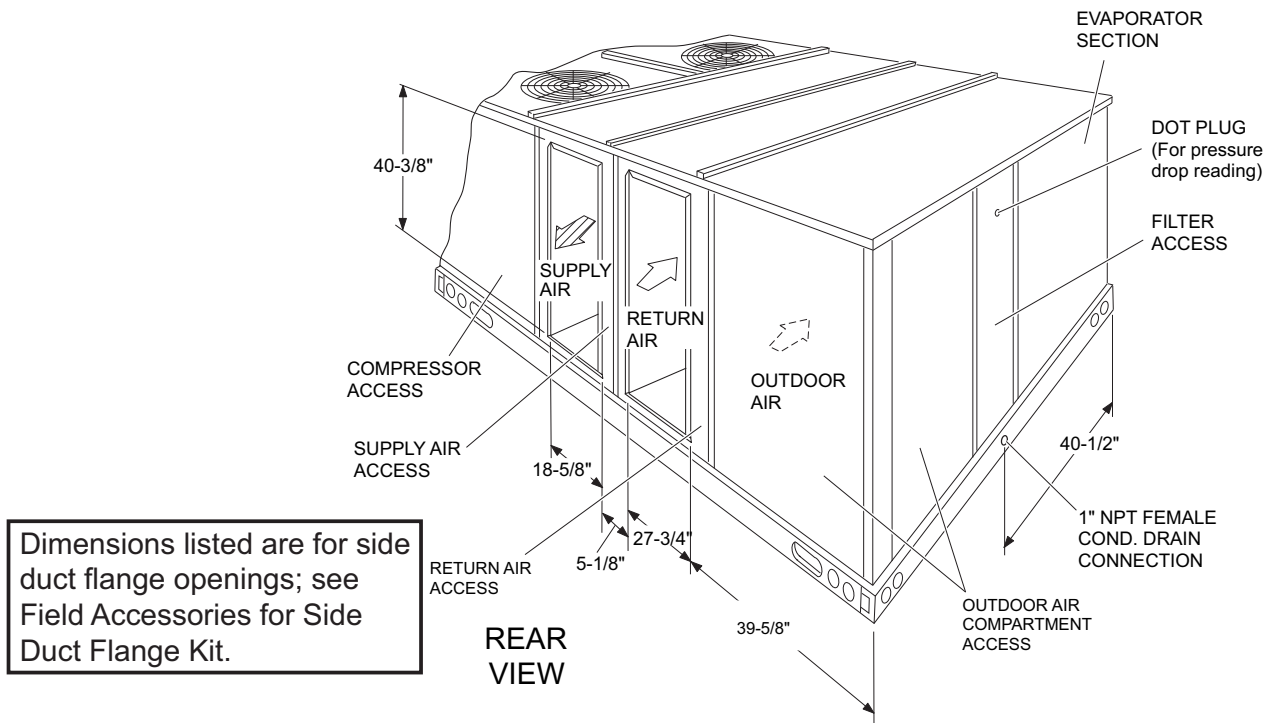

Dimensions listed are for side duct flange openings; see Field Accessories for Side Duct Flange Kit.

| LOCATION | CLEARANCE |
|---------------------------|--|
| Front | 36" |
| Rear | 24" (Less Economizer) 49" (With Economizer) |
| Left Side (Filter Access) | 24" (Less Economizer) 36" (With Economizer) ³ |
| Right Side (Cond. Coil) | 36" |
| Below Unit ¹ | 0" |
| Above Unit ² | 72" With 36" Maximum Horizontal Overhang (For Condenser Air Discharge) |

1. Units may be installed on combustible floors made from wood or class A, B, or C roof covering material.
2. Units must be installed outdoors. Overhanging structures or shrubs should not obstruct condenser air discharge outlet.
3. If economizer is factory installed, the unassembled rain hood must be removed from its ride along position in front of evaporator coil, or in the outdoor air compartment, prior to final installation.

NOTE: Units and ductwork are approved for zero clearance to combustible material when equipped with electric heaters.

UNITS WITH RAIN HOODS

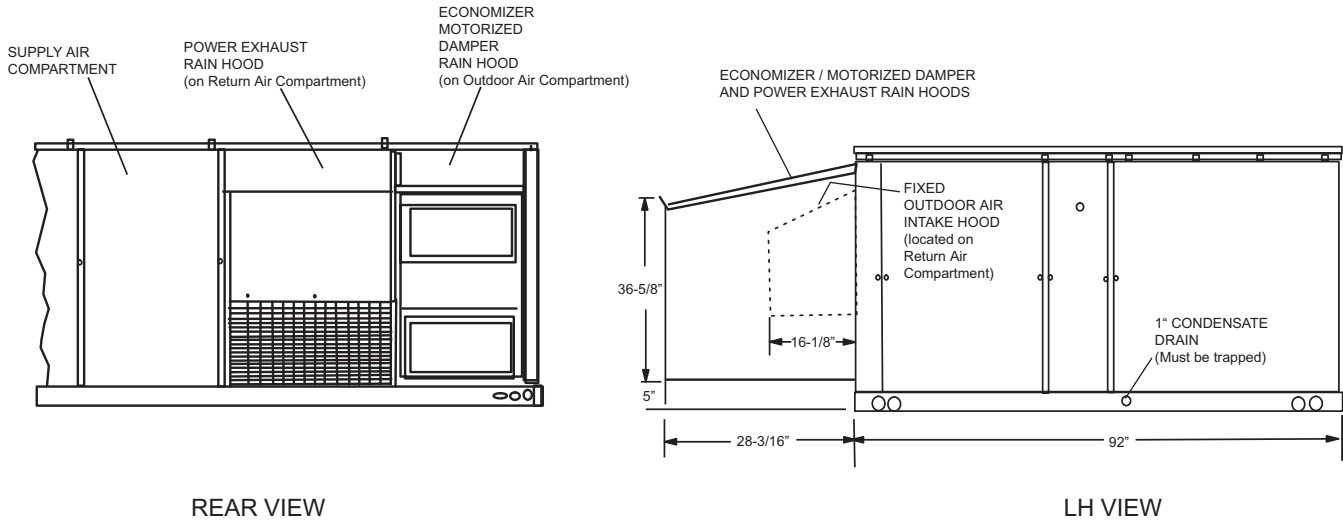

DETAIL "Y"
UNIT WITH RAIN HOODS

NOTES

REFER TO UNIT TECHNICAL GUIDE FOR THE LIST OF STANDARD FEATURES

ATTACHED NOT ATTACHED

Subject to change without notice. Printed in U.S.A.
Copyright © 2008 by Johnson Controls, Inc. All rights reserved.

260193-LSD-D-0508
Supersedes: 260193-LSD-C-0707

Johnson Controls Unitary Products
5005 York Drive
Norman, OK 73069