

ACCESSORY KIT INSTALLATION INSTRUCTION

AIR PROVING SWITCH (APS)

2AP0401

For Use With Simplicity™ INTELLI-Comfort™ and ModLINC

GENERAL

The following instruction provides all the necessary information to install the Air Proving Switch Kit.

The Kit includes the following:

- 1 ea. Air Proving Switch
- 2 ea. Pressure Port Connector
- 1 ea. 90"-1/4" Clear Tubing
- 2 ea. Drill Screw #10-16
- 2 ea. Speednut

INSTALLATION

Determine into which unit the kit is to be installed.

- 3-6 Ton with Simplicity™ INTELLI-Comfort™ with and without ModLINC
- 6.5-12.5 Ton with Simplicity™ INTELLI-Comfort™ with and without ModLINC
- 15-20 Ton with Simplicity™ INTELLI-Comfort™ with and without ModLINC

3-6 TON WITH Simplicity™ INTELLI-Comfort™ WITH AND WITHOUT ModLINC

1. Disconnect all electrical power to the unit.
2. Remove the blower section access panel.
3. Mount the Air Proving switch on the back of the unit control box and secure with two #10-16 screws and speed nuts.
4. Approximately in the middle of the blower housing, drill a .152" diameter hole (#24 Drill) for the blower low pressure port tube connector. See Figure 1. On the positive side of the blower, drill a .152" diameter hole (#24 Drill) to locate the high pressure port tube connector. Place the hole approximately 3" from the bottom of the blower and 3" to the left of the partition panel. See Figure 2.
5. Use a 5/16" socket to screw in the pressure port tube connectors.
6. Cut the required length of 1/4" clear tubing to connect the blower pressure port to the "Low" pressure side of the air proving switch.
7. Connect the 1/4" clear tubing to the blower "Low" pressure port and to the "Low" pressure port on the air proving switch.
8. Connect the remainder of 1/4" clear tubing to the blower "High" pressure port and to the "High or Unmarked" pressure port on the air proving switch.

9. Connect the wires from the factory installed harness to the Air Proving Switch, per the wiring diagram provided with the original unit.
10. Figure 1 shows complete installation in the 3-6 Ton cabinets.

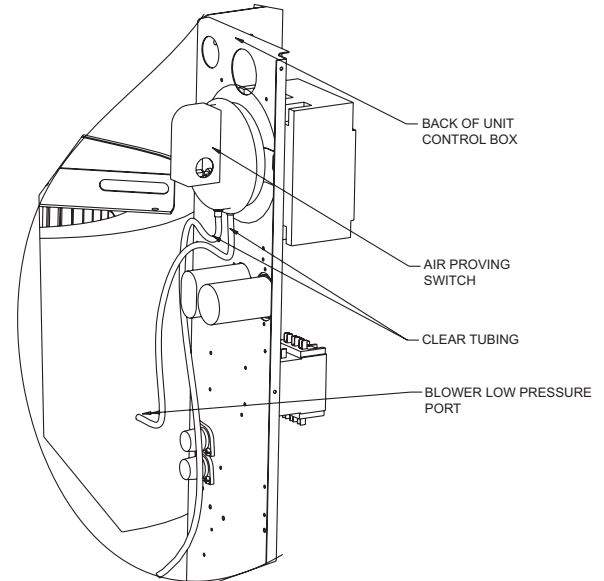

FIGURE 1: APS for 3-6 Ton Cabinets

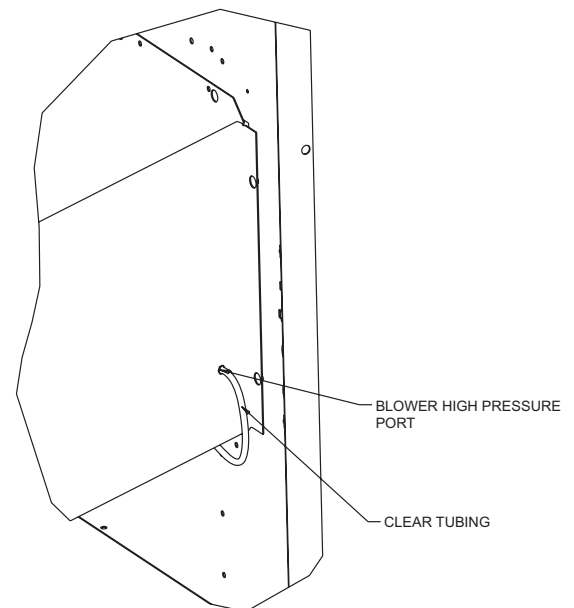

FIGURE 2: APS Hole Placement for 3-6 Ton Cabinets

6.5 - 12.5 TON WITH Simplicity™ INTELLI-Comfort™ WITH AND WITHOUT ModLINC

1. Disconnect all electrical power to the unit.
2. Remove the blower section access panel.
3. Mount the Air Proving Switch on the motor mount plate and secure with two #10-16 drill screws. (Figure 3 shows the approximate location and orientation) Switch must be mounted vertically with ports pointing down.
4. Approximately 2" below the bottom of the motor mount plate drill a .152" diameter hole (#24 Drill) into the blower housing for the blower pressure port tube connector.

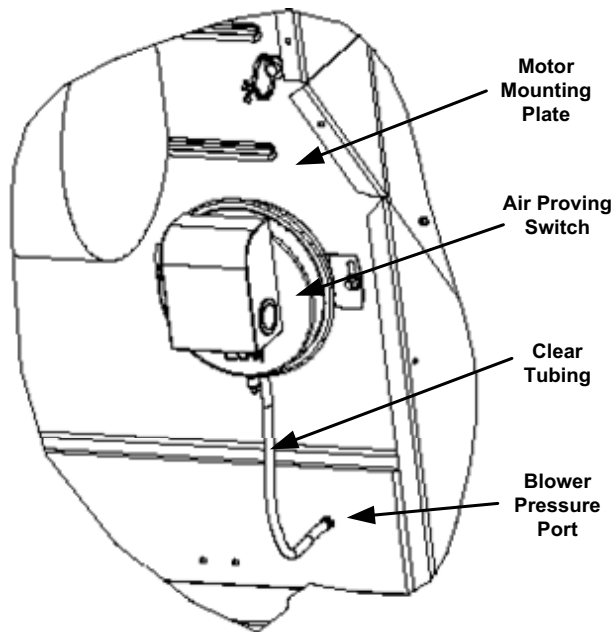

FIGURE 3: APS Location for 6.5 - 12.5 Ton Cabinets

5. Use a 5/16" socket to screw in the pressure port tube connector.
6. Cut the required length of 1/4" clear tubing to connect the blower pressure port to the "High or Unmarked" pressure side of the air proving switch.
7. Connect the 1/4" clear tubing to the blower pressure port and to the "High or Unmarked" pressure side of the air proving switch.
8. Leave the "Low" pressure port on the air-proving switch open.
9. Connect the wires from the factory installed harness to the Air Proving Switch, per the wiring diagram provided with the original unit.
10. Figure 3 shows complete installation in the 6.5-12.5 Ton cabinets.

15-25 TON WITH Simplicity™ INTELLI-Comfort™ WITH AND WITHOUT MODLINC

1. Disconnect all electrical power to the unit.
2. Remove the blower and heat section access panels.
3. Mount the Air Proving switch on the blower and secure with two #10-16 drill screws. (Figure 4 shows the approximate location and orientation) Switch must be mounted vertically with ports pointing down.
4. Approximately 2" below the Air Proving Switch drill a .152" diameter hole (#24 Drill) for the blower pressure port connector. In the upper part of the gas/electric heat section, drill a .152" diameter hole (#24 Drill) to locate a pressure tap. Place the hole approximately 11" inches to the right of the evaporator partition panel and 6" inches up from the flue box. (See Figure 4.)

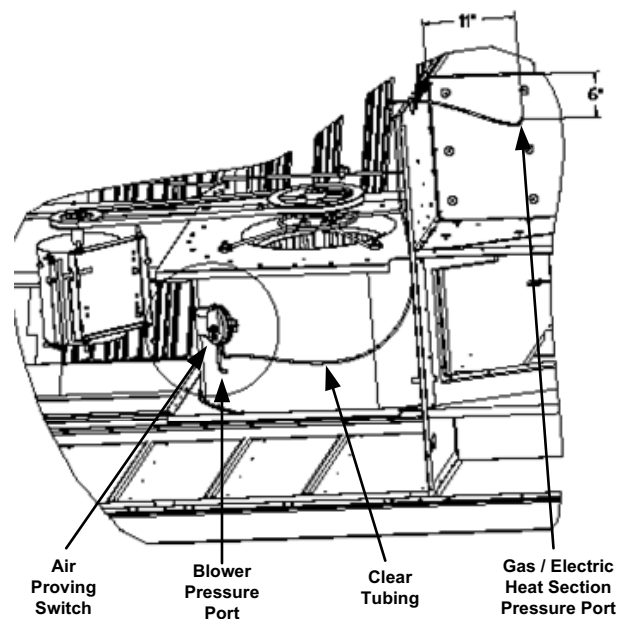

FIGURE 4: APS Location for 15 - 25 Ton Cabinets

5. Use a 5/16" socket to install the connection ports in the blower and in the gas/electric heat section.
6. Cut the required length of 1/4" clear tubing to connect the blower pressure port to the "Low" pressure side of the air proving switch.
7. Connect blower pressure port to the "Low" pressure side of the air proving switch.
8. Connect the remainder of 1/4" clear tubing to the "High or Unmarked" pressure side of the air proving switch.
9. Route the remainder of the 1/4" clear tubing along the wires through the square cut in the upper right front of the blower housing between the evaporator partition panel and the upper front right corner of the blower assembly.

10. Next, route the clear tubing through the second liquid line opening in the evaporator partition panel, underneath the liquid line. It may help to use a screwdriver or similar means to compress the insulation around the liquid line, in order to more easily route the tubing through the opening.
11. Connect the "High or Unmarked" pressure side of the air-proving switch to the pressure tap installed in the gas/ electric heat section.
12. Connect the wires from the factory installed harness to the Air Proving Switch, per the wiring diagram provided with the original unit.
13. Figure 4 shows complete installation in the 15-25 Ton cabinets.

