

# SUBMITTAL DATA SHEET



**SINGLE PACKAGE HEAT PUMP  
MODELS: BA-03, -04, -05 & -A6**

JOB NAME:		LOCATION:		
PURCHASER:		ORDER NO:		
ENGINEER:				
SUBMITTED TO:	FOR:	REF:	APPROVAL:	CONSTRUCTION:
SUBMITTED BY:		DATE:		
UNIT DESIGNATION:		SCHEDULE NO.	MODEL NO.	

## FACTORY INSTALLED OPTIONS

**COOLING PERFORMANCE**

TOTAL CAPACITY----- MBH

SENSIBLE CAPACITY ----- MBH

OUTDOOR DESIGN TMP. \_\_\_\_\_ °F DB/WB

TOTAL SUPPLY AIR ----- CFM

TEMP. OF AIR ENTERING

EVAPORATOR COIL ----- °F

POWER INPUT REQ. ----- KW  
(LESS BLOWER MOTOR)

**HEATING PERFORMANCE**

CAPACITY

    @ 47°F----- MBH

    @ 17°F----- MBH

COEFFICIENT OF PERFORMANCE

    @ 47°F----- MBH

    @ 17°F----- MBH

(RESISTANCE HEAT - SEE REVERSE SIDE)

**SUPPLY AIR BLOWER PERFORMANCE**

TOTAL SUPPLY AIR ----- CFM

EXT. STATIC PRESS. ----- IWG

BLOWER SPEED----- RPM

POWER OUTPUT REQ. ----- BHP

MOTOR RATING ----- HP

POWER INPUT REQ. ----- KW

**ELECTRICAL DATA**

POWER SUPPLY-----

TOTAL UNIT AMPACITY ----- AMPS

MAX. OVERCURRENT DEVICE

\_\_\_ FUSE \_\_\_ BREAKER ----- AMPS

**TOTAL UNIT WEIGHT**

INCLUDING FACTORY- INSTALLED  
OPTIONS----- LBS

- SINGLE INPUT ELECTRONIC ENTHALPY ECONOMIZERS -----
- MOTORIZED OUTDOOR AIR INTAKE DAMPER-----
- PHENOLIC COATED EVAPORATOR COILS-----
- PHENOLIC COATED CONDENSER COILS -----
- ELECTRIC HEATERS -----
- FILTER (2" PLEATED)-----
- POWERED CONVENIENCE OUTLET-----
- NON-POWERED CONVENIENCE OUTLET -----
- DISCONNECT SWITCH-----
- BAS - (BUILDING AUTOMATION SYSTEMS) -----
- Simplicity® Intelli-Comfort™ -----
- Honeywell™ -----
- Novar® -----
- Johnson -----
- CPC -----
- SMOKE DETECTOR (RETURN)-----
- SMOKE DETECTOR (SUPPLY) -----
- COIL GUARD -----
- STAINLESS STEEL DRAIN PAN -----
- BAS READY ECONOMIZER (2-10 V.D.C. ACTUATOR WITHOUT  
A CONTROLLER) -----
- AIR PROVING SWITCH-----
- PHASE MONITOR-----
- BELT DRIVE -----
- BELT DRIVE (HIGH STATIC) -----
- DIRECT DRIVE -----
- DIRTY FILTER SWITCH -----
- HINGED FILTER DOOR/"TOOLLESS" BLOWER AND ACCESS  
PANELS (NOT HINGED) -----

## FIELD INSTALLED ACCESSORIES

- SINGLE INPUT ELECTRONIC ENTHALPY ECONOMIZERS -----
- ENTHALPY ACCESSORY CONTROL KIT (DUAL)-----
- MOTORIZED OUTDOOR AIR INTAKE DAMPER-----
- ROOF CURBS -----
- BAROMETRIC RELIEF DAMPER -----
- BURGLAR BARS-----
- CO<sub>2</sub> SENSOR, UNIT MOUNT-----
- CO<sub>2</sub> SENSOR, SPACE MOUNT -----
- DIRTY FILTER SWITCH -----
- AIR PROVING SWITCH-----
- POWER EXHAUST -----
- ELECTRIC HEAT -----
- COIL GUARDS -----
- HAIL GUARDS -----
- WALL MOUNT TEMPERATURE SENSOR (Intelli-Comfort™) -----
- WALL MOUNT TEMPERATURE SENSOR WITH  
OVERRIDE (Intelli-Comfort™) -----
- WALL MOUNT TEMPERATURE SENSOR WITH OVERRIDE  
& SET POINT ADJ. (Intelli-Comfort™) -----
- HUMIDITY SENSOR (Intelli-Comfort™)-----

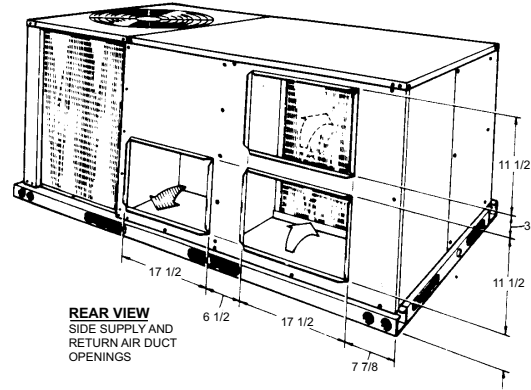
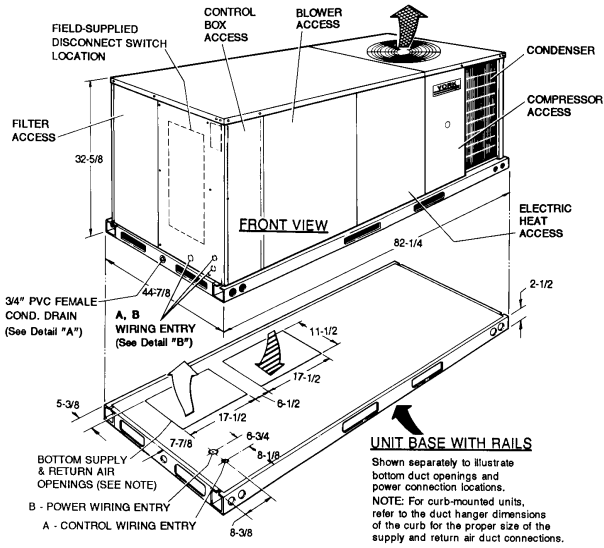

**UTILITIES ENTRY DATA**

HOLE	KNOCKOUT SIZE (DIA.)	USED FOR
A	7/8"	Control Wiring (Side or Bottom)
B	2"	Power Wiring (Side or Bottom)

**UNIT BASE WITH RAILS**  
 Shown separately to illustrate bottom duct openings and power connection locations.  
 NOTE: For curb-mounted units, refer to the duct hanger dimensions of the curb for the proper size of the supply and return air duct connections.

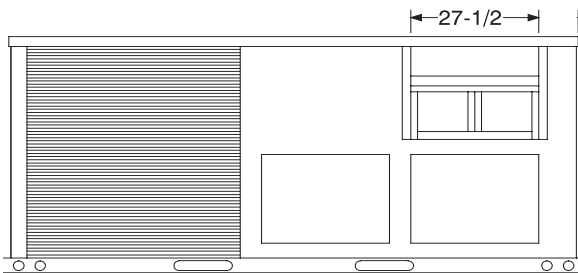
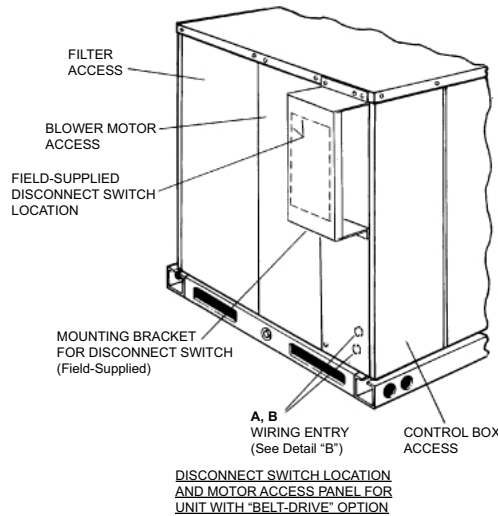

REAR VIEW

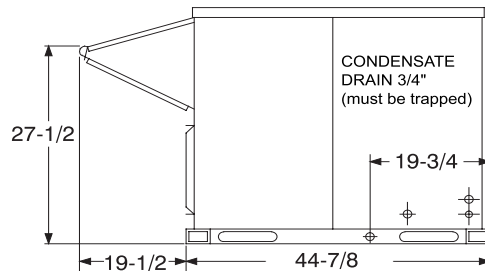

L.H. END VIEW

**DETAIL "A"  
 UNIT WITH ECONOMIZER RAINHOOD**

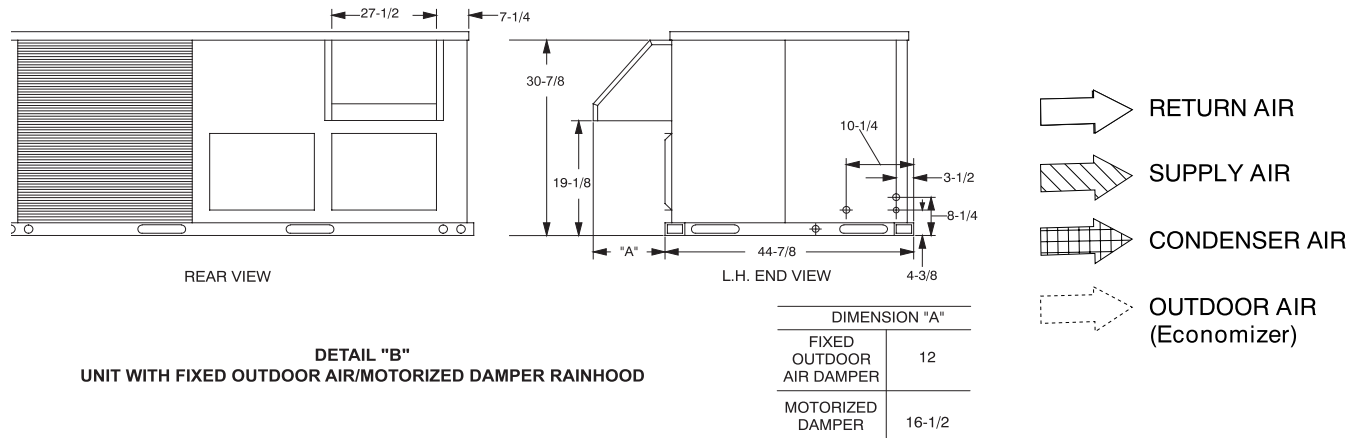

**MINIMUM CLEARANCES**

LOCATION	CLEARANCE
Front	24" (Cooling/Electric Heat)
Rear	12" (Less Economizer) 36" (With Economizer or Fixed Air/Motorized Damper)
Left Side (Filter Access)	24" (Less Economizer) 36" (With Economizer)
Right Side (Cond. Coil)	24"
Below Unit <sup>1</sup>	0"
Above Unit <sup>2</sup>	72" (For Condenser Air Discharge)

1. Units may be installed on combustible floors made from wood or class A, B, or C roof covering material.
2. Units must be installed outdoors. Overhanging structures or shrubs should not obstruct condenser air discharge outlet.

**NOTE:** Units and ductwork are approved for zero clearance to combustible materials when equipped with electric heaters.

**NOTE:** All entry holes should be field sealed to prevent rain water entry into building.

# NOTES

**REFER TO TECHNICAL GUIDE FOR THE LIST OF STANDARD FEATURES**

**ATTACHED**  **NOT ATTACHED**

Subject to change without notice. Printed in U.S.A.  
Copyright © 2008 by Johnson Controls, Inc. All rights reserved.

256387-LSD-C-0408  
Supersedes: 256387-LSD-B-0507

---

**Johnson Controls Unitary Products**  
**5005 York Drive**  
**Norman, OK 73069**