

SUBMITTAL DATA SHEET



SPLIT SYSTEM 4-PIPE HEAT PUMP EVAPORATOR BLOWER 15 TONS - MODELS: F*HP180

| | | | | |
|-------------------|------|--------------|-----------|---------------|
| JOB NAME: | | LOCATION: | | |
| PURCHASER: | | ORDER NO: | | |
| ENGINEER: | | | | |
| SUBMITTED TO: | FOR: | REF: | APPROVAL: | CONSTRUCTION: |
| SUBMITTED BY: | | DATE: | | |
| UNIT DESIGNATION: | | SCHEDULE NO. | | MODEL NO. |

PRODUCT DATA

Cooling Performance

Total Capacity MBH
 Sensible Capacity MBH
 Evaporator Pressure
 at Saturation PSI
 Evaporator Temperature
 at Saturation °F
 Total Supply Air CFM
 Temp. of Air Entering
 Evaporator Coil..... / °F DB/WB

Heating Performance

Refer to field-installed accessories on reverse side

Supply Air Blower Performance

Total Supply Air CFM
 Total Resistance External To Unit IWG
 Blower Speed RPM
 PWR Output Req. BHP
 Motor Rating HP
 PWR Input Req. kW

Electrical Data

Power Supply AMPS
 Total Unit Ampacity .. AMPS
 Min. Wire Size AWG
 (Copper Conductors)
 Max. Fuse Size Dual Element AMPS

Unit Weight

Total Operating Weight LBS
 (Including field-installed accessories)

Matching Condensing Unit Data

Model Number _____
 Submittal Form Number _____

DIMENSIONS - INCHES

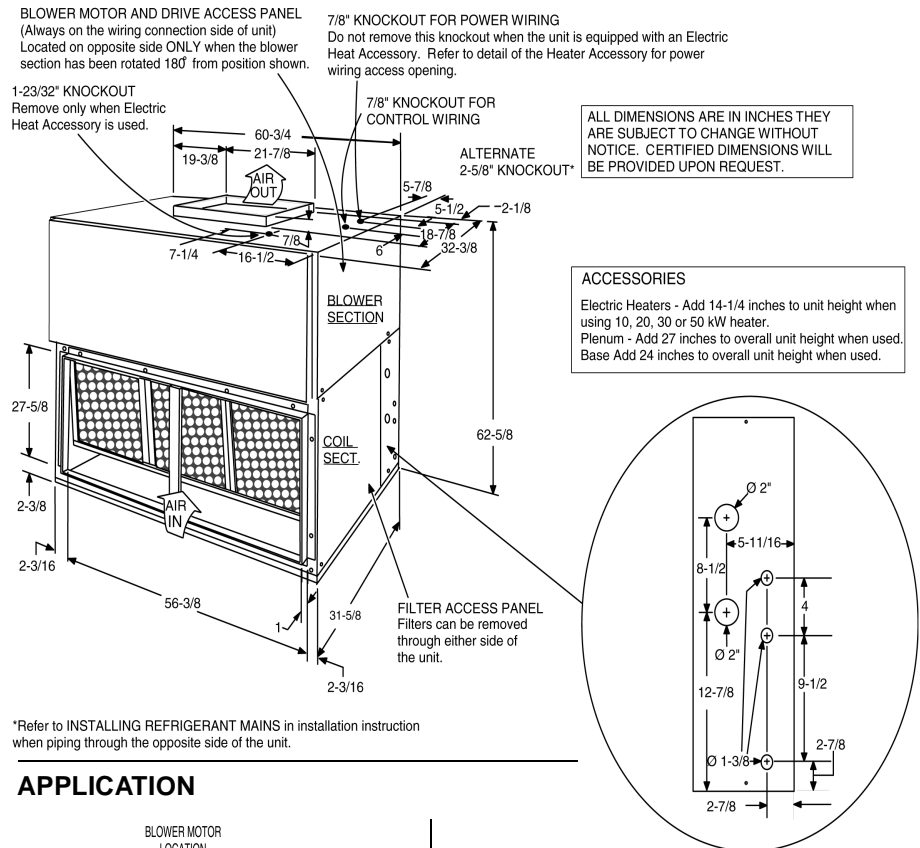

*Refer to INSTALLING REFRIGERANT MAINS in installation instruction when piping through the opposite side of the unit.

APPLICATION

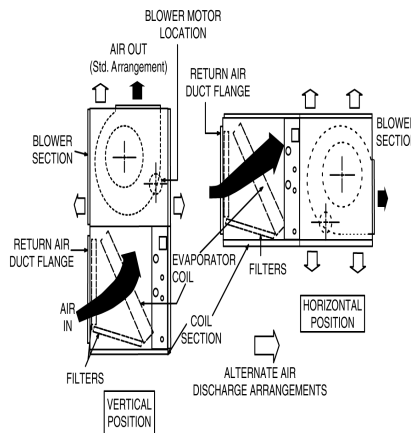

NOTE: CERTAIN BLOWER POSITIONS ARE NOT RECOMMENDED. BECAUSE THE BLOWER MOTOR SHOULD NOT BE MOUNTED UPSIDE DOWN.

MINIMUM CLEARANCES

- Side with RETURN AIR opening 24"¹
- Side with SUPPLY AIR opening 24"¹
- Side with PIPING CONNECTION 61"²
- Side opposite PIPING CONNECTION 26"³
- Bottom 4

¹ Overall dimension of the unit will vary if an electric heater, a supply air plenum or a base is used.
² This dimension is required for removal of the coil. Only 26" is required for normal servicing.
³ If the coil has to be removed, this dimension is required to loosen screws that secure the coil to the unit frame. This dimension will also be required for blower motor access if the piping connections are made on the opposite side of the unit.
⁴ Allow enough clearance to trap the condensate drain line.

BASIC UNIT SUSPENSION WEIGHTS (LBS.)

| Susp'n Point | With 2 HP Motor | With Heater Access | With Plenum Access | With Heater & Plenum Access |
|--------------|-----------------|--------------------|--------------------|-----------------------------|
| A | 95 | 95 | 85 | 85 |
| B | 120 | 120 | 100 | 100 |
| C | 95 | 115 | 165 | 185 |
| D | 115 | 140 | 185 | 205 |
| Total Wt. | 425 | 470 | 535 | 575 |

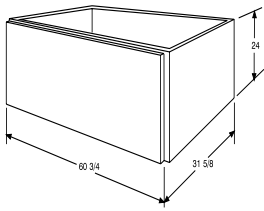

BASE

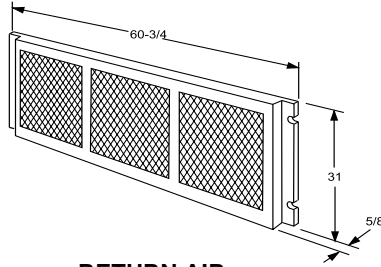

RETURN AIR GRILLE

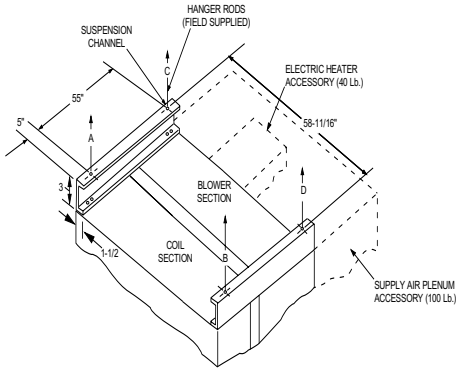

SUSPENSION ACCESSORY ARRANGEMENT 15 TON

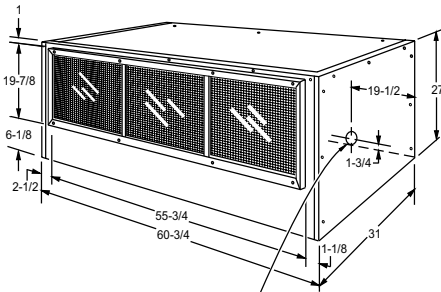

SUPPLY AIR PLENUM

2-1/2 KNOCKOUT FOR POWER WIRING WHEN ELECTRIC HEATER IS USED

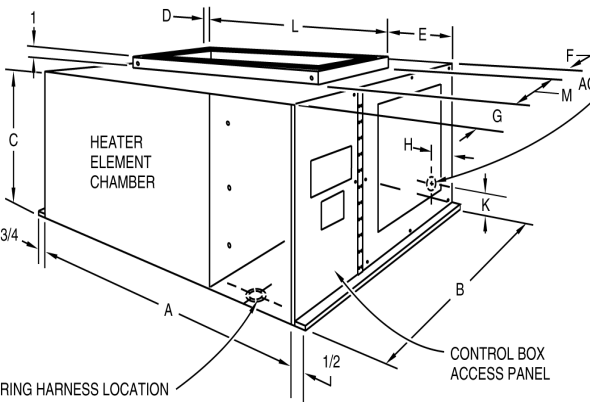

WIRING HARNESS LOCATION

This opening in the bottom of the heater control box is used for the wiring harness that connects the heater accessory to the basic unit. It is provided with a squeeze connector for securing the wiring harness, and its location corresponds to the location of the 1-23/32 inch knockout in the top panel of the basic unit.

10KW THRU 30KW - Add a 1-1/4 inch conduit fitting to the 1-23/32 inch hole for wire sizes up through #1 AWG. Remove the knockout ring and add a 1-1/2 inch conduit fitting to the 1-31/32 inch hole for wire sizes up through #0 AWG.

50 KW - Add a 1-1/4 inch conduit fitting to the 1-23/32 inch hole for wire sizes up through #1 AWG. Remove the knockout ring and add a two-inches conduit fitting to the 2-1/2" hole for wire sizes up through #000 AWG. Used on FEH180 only.

ELECTRIC HEATER DIMENSIONS

| Heater Model | Nom. kW | Heater Dimensions (inches) | | | | | | | | | | | | |
|-----------------|---------|----------------------------|--------|--------|-------|-------|-----|-------|-------|-------|--------|--------|--|--|
| | | A | B | C | D | E | F | G | H | K | L | M | | |
| 2HB04501025, 46 | 10 | | | | | | | | | | | | | |
| 2HB04502005, 46 | 20 | 27-1/4 | 25-1/4 | 14-1/4 | 1 | 4 | 1/2 | 5-1/2 | 1-1/2 | 1-1/2 | 22-1/4 | 19-1/4 | | |
| 2HB04503025, 46 | 30 | | | | | | | | | | | | | |
| 2HB04505025, 46 | 50 | 29-7/8 | 26-3/8 | 21-3/4 | 2-3/8 | 5-1/4 | 3/4 | 6-3/4 | 2-1/4 | 2-1/2 | 22-1/4 | 19-1/4 | | |

FIELD-INSTALLED ACCESSORIES

- SUPPLY AIR PLENUM (1SP0452)
- RETURN AIR GRILLE(1RG0452).....
- BASE (1BS0452) (Vertical Application Only)
- SUSPENSION PACKAGE(1HH0451)
- (Horizontal Application Only)
- ELECTRIC HEATER*
- Model Number..... _____
- Capacity (@ _____ Volts)..... _____ MBH
- Power Input Requirement..... _____ kW
- (Less Blower Motor)

* Units with electric heat have a single source power supply. Refer to Product Data on front side for electric data