

INSTALLATION MANUAL

VARIABLE SPEED SINGLE PIECE MODULAR AIR HANDLERS

MODELS: F2FV060 / F3FV060(T)

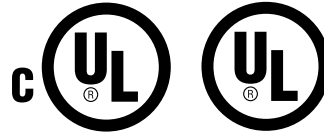

TABLE OF CONTENTS

SAFETY	1	COIL METERING DEVICES	5
SPECIFIC SAFETY RULES AND PRECAUTIONS	2	REFRIGERANT LINE CONNECTION	6
SAFETY REQUIREMENTS	2	ELECTRIC HEATERS & OPERATING CONTROLS	6
GENERAL INFORMATION	2	LOW VOLTAGE CONTROL CONNECTION	7
INSPECTION	2	LINE POWER CONNECTIONS	7
LIMITATIONS	2	BLOWER SPEED SELECTION	8
CLEARANCES	2	DRAIN CONNECTIONS	12
LOCATION	2	MAINTENANCE	12
HORIZONTAL DRAIN PAN CONVERSION	3	COIL CLEANING	12
DUCT CONNECTORS	5	LUBRICATION	12
AIR FILTERS	5	CONDENSATE DRAINS	12
SUSPENSION KITS	5		

LIST OF FIGURES

Plenum Clearances	3	Control Board	7
Typical Installation	3	Electric Heaters in Horizontal Configuration - Right Hand Air Flow ..	7
Filter Access & Drain Pan Conversion / Coil Baffle	4	Line Power Connections	7
Dimensions & Duct Sizes	4	CFM Selection Board Detail	8
Typical Horizontal Installation	5	Control Box	8
TXV Bulb Installation	5	Cooling Models with Electric Heat Wiring	10
Bulb Location	6	Two-Stage Cooling Wiring	11
Orifice Installation	6	Heat Pump Wiring	11

LIST OF TABLES

Dimensions	4	Electrical Data - Cooling Only	9
Installed Orifice or TXV Sizes	5	Electrical Data - (for Single Source Power Supply) -	
CFM / Tap Selection	8	Copper Wire 208/230-1-60	10
Physical and Electrical Data	9	Electrical Data - (for Single Source Power Supply) -	
Conversion Table	9	Copper Wire 208/230-3-60	10
Electrical Data - 1 Ø - 208/230-1-60	9	Electrical Data - (for Multi-Source Power Supply) -	
Electrical Data - 3 Ø - 208/230-3-60	9	Copper Wire 208/230-1-60	10

SAFETY



This is a safety alert symbol. When you see this symbol on labels or in manuals, be alert to the potential for personal injury.

Understand and pay particular attention to the signal words **DANGER**, **WARNING**, or **CAUTION**.

DANGER indicates an **imminently** hazardous situation, which, if not avoided, **will result in death or serious injury**.

WARNING indicates a **potentially** hazardous situation, which, if not avoided, **could result in death or serious injury**.

CAUTION indicates a potentially hazardous situation, which, if not avoided **may result in minor or moderate injury**. It is also used to alert against unsafe practices and hazards involving only property damage.

WARNING

Improper installation may create a condition where the operation of the product could cause personal injury or property damage.

Improper installation, adjustment, alteration, service or maintenance can cause injury or property damage. Refer to this manual for assistance or for additional information, consult a qualified contractor, installer or service agency.

CAUTION

This product must be installed in strict compliance with the installation instructions and any applicable local, state, and national codes including, but not limited to building, electrical, and mechanical codes.

SPECIFIC SAFETY RULES AND PRECAUTIONS

▲WARNING

FIRE OR ELECTRICAL HAZARD

Failure to follow the safety warnings exactly could result in serious injury, death or property damage.

A fire or electrical hazard may result causing property damage, personal injury or loss of life.

1. Install this air handler only in a location and position as specified in SECTION I of these instructions.
2. Always install the air handler to operate within the air handler's intended maximum outlet air temperature. Only connect the air handler to a duct system which has an external static pressure within the allowable range, as specified on the air handler rating plate.
3. When a air handler is installed so that supply ducts carry air circulated by the air handler to areas outside the space containing the air handler, the return air shall also be handled by duct(s) sealed to the air handler casing and terminating outside the space containing the air handler.
4. The air handler is not to be used for temporary heating of buildings or structures under construction.
5. The size of the unit should be based on an acceptable heat loss calculation for the structure. ACCA, Manual J or other approved methods may be used.

SAFETY REQUIREMENTS

- This air handler should be installed in accordance with all national and local building/safety codes and requirements, local plumbing or wastewater codes, and other applicable codes.
- Refer to the unit rating plate for the air handler model number, and then see the dimensions page of this instruction for supply air plenum dimensions in Figure 1. The plenum must be installed according to the instructions.
- Provide clearances from combustible materials as listed under Clearances to Combustibles.
- Provide clearances for servicing ensuring that service access is allowed for both the burners and blower.
- **Failure to carefully read and follow all instructions in this manual can result in air handler malfunction, death, personal injury and/or property damage.**
- Check the rating plate and power supply to be sure that the electrical characteristics match.
- Air handler shall be installed so the electrical components are protected from water.
- Installing and servicing heating equipment can be hazardous due to the electrical components. Only trained and qualified personnel should install, repair, or service heating equipment. Untrained service personnel can perform basic maintenance functions such as cleaning and replacing the air filters. When working on heating equipment, observe precautions in the manuals and on the labels attached to the unit and other safety precautions that may apply.
- These instructions cover minimum requirements and conform to existing national standards and safety codes. In some instances these instructions exceed certain local codes and ordinances, especially those who have not kept up with changing residential and non-HUD modular home construction practices. These instructions are required as a minimum for a safe installation.

GENERAL INFORMATION

This Single Piece Air Handler provides the flexibility for installation in any upflow or horizontal application. These versatile models may be used for cooling or heat pump operation with or without electric heat. The variable-speed (ECM) motors provide a selection of air volume to match any application.

BRAND LABEL (available from Distribution) apply to center of the blower access panel.

The unit can be positioned for bottom return air in the upflow position, and right or left return in the horizontal position.

Top and side power wiring and control wiring, accessible screw terminals for control wiring, easy to install drain connections and electric heaters all combine to make the installation easy, and minimize installation cost.

INSPECTION

As soon as a unit is received, it should be inspected for possible damage during transit. If damage is evident, the extent of the damage should be noted on the carrier's freight bill. A separate request for inspection by the carrier's agent should be made in writing. Also, before installation the unit should be checked for screws or bolts, which may have loosened in transit. There are no shipping or spacer brackets which need to be removed.

Also check to be sure all accessories such as heater kits, suspension kits, and coils are available. Installation of these accessories or field conversion of the unit should be accomplished before setting the unit in place or connecting any wiring, electric heat, ducts or piping.

LIMITATIONS

These units must be wired and installed in accordance with all national and local safety codes.

Voltage limits are as follows:

Air Handler Voltage	Voltage code	¹ Normal Operating Voltage Range
208/230-1-60	06	187-253

1. Rated in accordance with ARI Standard 110, utilization range "A".

Airflow must be within the minimum and maximum limits approved for electric heat, evaporator coils and outdoor units.

Entering Air Temperature Limits			
Wet Bulb Temp. °F		Dry Bulb Temp. °F	
Min.	Max.	Min.	Max.
57	72	65	95

CLEARANCES

Clearance must be provided for:

1. Refrigerant piping and connections - minimum 12" recommended.
2. Maintenance and servicing access - minimum 36" from front of unit recommended for blower motor / coil replacement.
3. Condensate drain line.
4. Filter removal - minimum 36" recommended.

LOCATION

Location is usually predetermined. Check with owner's or dealer's installation plans. If location has not been decided, consider the following in choosing a suitable location:

1. Select a location with adequate structural support, space for service access, clearance for air return and supply duct connections.
2. Use hanging brackets to wall mount unit as shown below.
3. Normal operating sound levels may be objectionable if the air handler is placed directly over some rooms such as bedrooms, study, etc.

4. Precautions should be taken to locate the unit and ductwork so that supply air does not short circuit to the return air.
5. Select a location that will permit installation of condensate line to an open drain.

NOTE: When the coil is installed in a draw-thru application, it is recommended to trap the primary and secondary drain line. If the secondary drain line is not used, it must be capped.

The coil is provided with a secondary drain. It should be piped to a location that will give the occupant a visual warning that the primary drain is clogged. If the secondary drain is not used it must be capped.

6. When an evaporator coil is installed in an attic or above a finished ceiling, an auxiliary drain pan should be provided under the coil as is specified by most local building codes.
7. Proper electrical supply must be available.
8. Clearances must also be taken into consideration, and provided for as follows:
 - A. Refrigerant piping and connections are located in the front.
 - B. Maintenance and servicing through the front or access side of unit with both sides and rear of unit having zero inch clearance.
 - C. Condensate drain lines are connected in the front (clear of filter).
 - D. Filter removal.

- E. When no electric heat is used, the unit as well as all duct work and plenum are designed for zero clearance to combustible materials.

CAUTION

If electric heat is used, a minimum clearance of 1" must be maintained on all sides of the supply air duct and/or plenum continuously for up to 3' (See Figure 1).

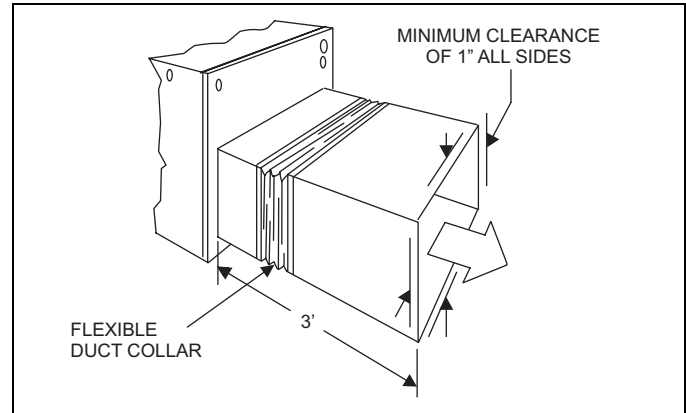

FIGURE 1: Plenum Clearances

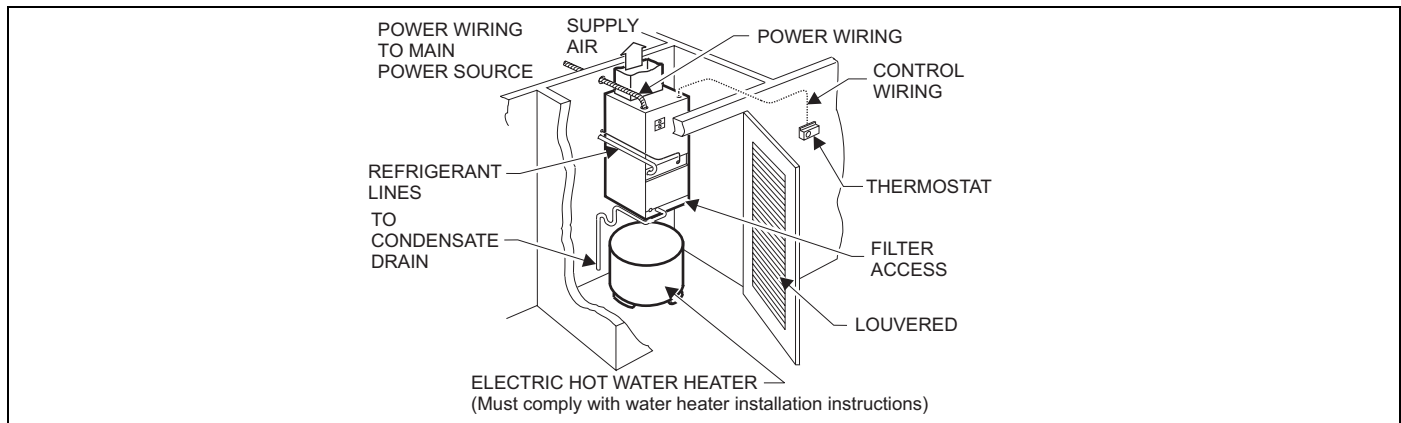

FIGURE 2: Typical Installation

HORIZONTAL DRAIN PAN CONVERSION

These air handler units are supplied ready to be installed in a right hand horizontal position. If unit requires left hand positioning, the unit must have the pan installed in the correct position.

1. Remove blower access, coil access, and center access panels.

NOTE: Conversion must be made before brazing the refrigerant connections to the coil.

2. See Figure 3, remove two screws from horizontal drain pan, to remove pan from position "4A" if factory installed.
3. Position horizontal pan, as required in either "A" or "B" position, locking it into the vertical drain pan as shown.
4. Horizontal drain pans have 4 plugged drains. Remove plugs from connections being used.

NOTE: If this step is overlooked, it can lead to a water problem later.

5. Use removed plug to plug primary of upflow drain pan.
6. Attach horizontal pan with 2 screws removed in step no. 2 or supplied with the unit. Ensure that the drain pan is lying flat against the insulation of the cabinet.
7. Horizontal drain cutout in the center access panel should be removed by using a utility knife (if not previously cut out).

CAUTION

DO NOT TRY TO KNOCK OUT PANEL OPENING FOR SECONDARY DRAIN PAN. SEE ITEM 7.

8. Re-position and replace access panels.

CAUTION

Models F(2,3)FV060 have a coil baffle and support bracket factory installed for right hand horizontal application (refer to Figure 3C). For left hand applications the coil support bracket must be moved to the right side of the coil, and the coil baffle must be rotated to avoid water blow-off.

To rotate baffle, remove the coil assembly from the unit (remove front two screws holding the coil support bracket and the two screws holding the drain pan). Remove four screws in coil baffle and remove the coil baffle and rotate ends.

Resecure the baffle and reinstall the coil assembly ensuring that the rear of the drain pan is secured under the back flange of the unit. Reinstall the coil support bracket on the right side of the coil.

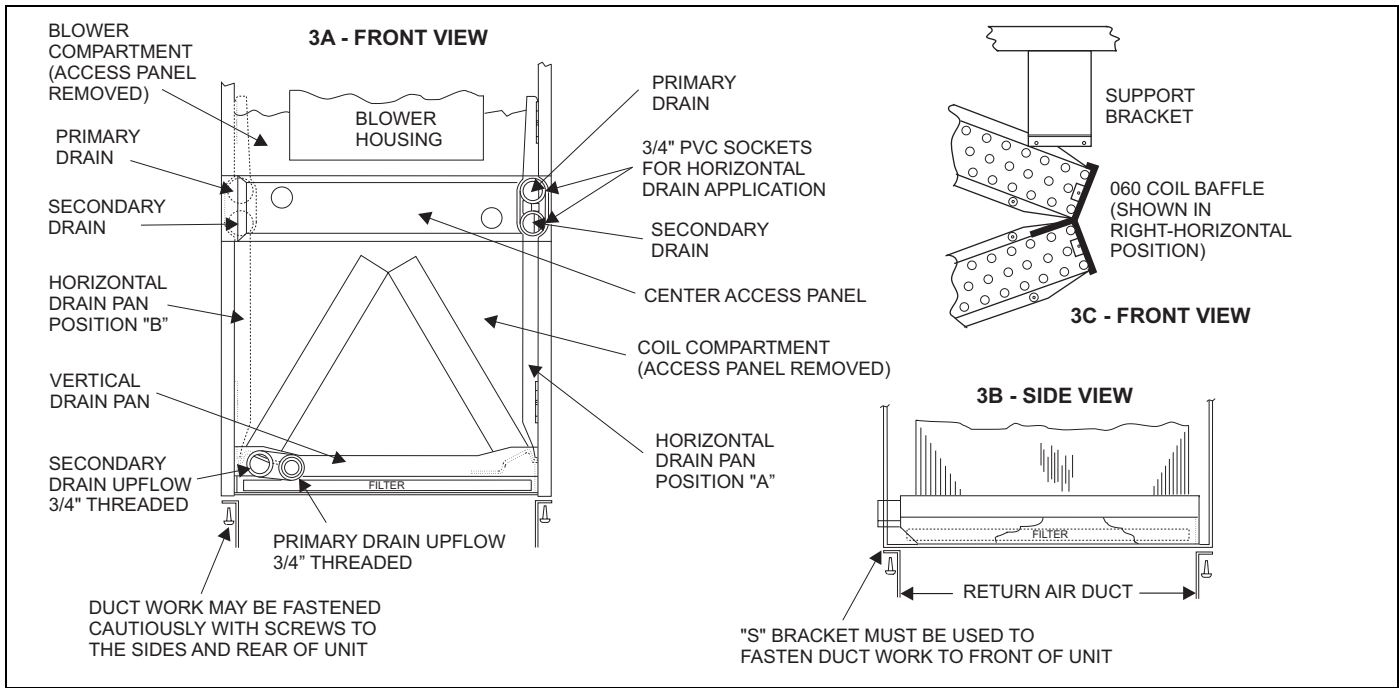

FIGURE 3: Filter Access & Drain Pan Conversion / Coil Baffle

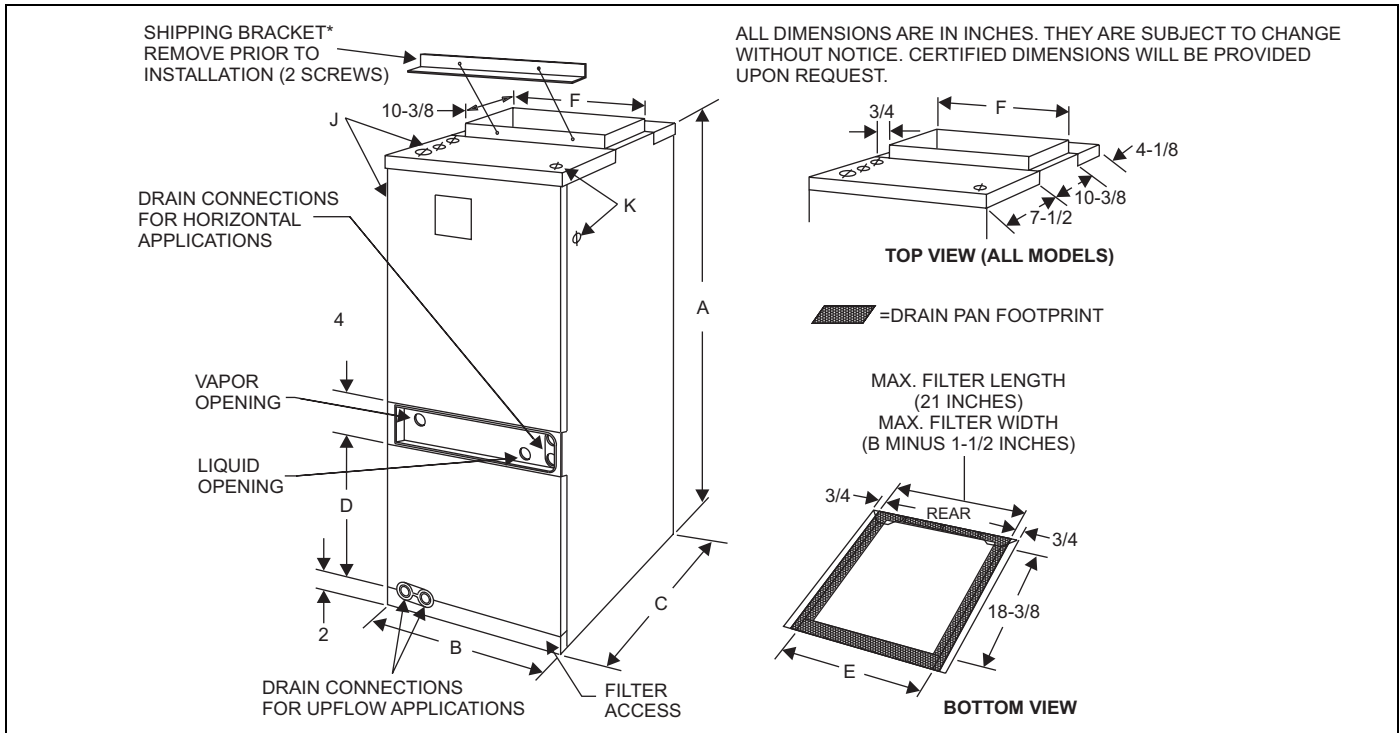

FIGURE 4: Dimensions & Duct Sizes

TABLE 1: Dimensions

MODEL F2FV / F3FV(T)	Dimensions						Wiring K.O.'s*		Refrigerant Connections Line Size	
	A	B	C	D	E	F	J	K		
	Height	Width	Depth				Power	Control	Liquid	Vapor
060	50-3/4	24	22	17-3/8	20-7/8	22-1/2	7/8 (1/2) 1-3/8 (1), 1-23/32 (1-1/4)	7/8 (1/2)	3/8	7/8

DUCT CONNECTORS

▲ WARNING

Use 1/2" screws to connect ductwork to bottom of unit. Longer screws will pierce the drain pan and cause leakage. If pilot holes are drilled, drill only through field duct and unit bottom flange.

NOTE: The electric heat accessory should be installed before the supply air duct is attached to the supply air openings. Refer to the electric heater kit instructions for proper installation.

Air supply and return may be handled in one of several ways best suited to the installation. See Figure 4 for dimensions for duct inlet and outlet connections.

The vast majority of problems encountered with combination heating and cooling systems can be linked to improperly designed or installed duct systems. It is therefore highly important to the success of an installation that the duct system be properly designed and installed.

Use flexible duct collars to minimize the transmission of vibration/noise into the conditioned space. If electric heat is used, non-flammable material must be used.

Where return air duct is short, or where sound may be a problem, sound absorbing glass fiber should be used inside the duct. Insulation of duct work is a must where it runs through an unheated space during the heating season or through an uncooled space during the cooling season. The use of a vapor barrier is recommended to prevent absorption of moisture from the surrounding air into the insulation.

The supply air duct should be properly sized by use of a transition to match unit opening. All ducts should be suspended using flexible hangers and never fastened directly to the structure. This unit is not designed for non-ducted (freeblow) applications. Size outlet plenum or transition to discharge opening sizes shown in Figure 4.

Duct work should be fabricated and installed in accordance with local and/or national codes. This includes the standards of the National Fire Protection Association for Installation of Air-Conditioning and Ventilating Systems, NFPA No. 90B.

AIR FILTERS

Air filters must be field supplied. A 1" filter access rack has been built into the unit. See Figure 4. Remove filter access cover shown. Install proper size filter. Standard 1" size permanent or throw away filter may be used, or, permanent washable filters are available using model number: 1PF603BK only. See Table 4 for filter size.

▲ CAUTION

Equipment should never be operated without filters.

SUSPENSION KITS

A suspension kit is available. Models 1BH0601 (unit sizes 018-060) is designed specifically for the units contained in this instruction (upflow application only). For installation of these accessory kits, see the instructions packed with the kit.

For suspension of these units in horizontal applications, it is recommended to use angle steel support brackets with threaded rods, supporting the units from the bottom, at the locations shown in Figure 5.

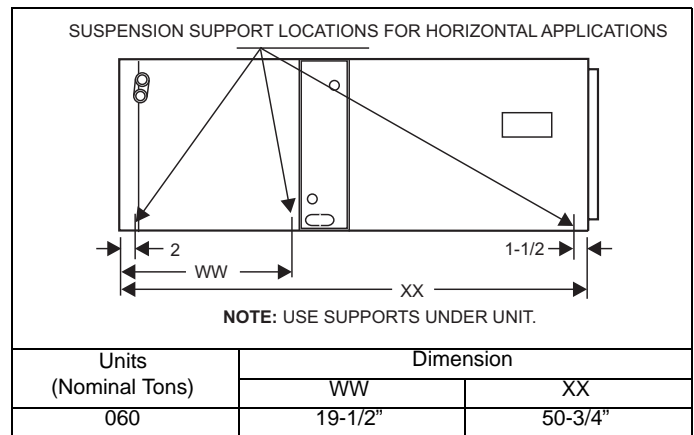

FIGURE 5: Typical Horizontal Installation

COIL METERING DEVICES

The coil in this Air Handler unit will have a metering device installed at the factory.

If the model number is of the following format:

F3FVH06T - The coil will have a Thermal Expansion Valve (TXV) installed. Please refer to the TXV Metering Device section for installation notes.

If the model number is of the following model series:

F2FV - The coil will have an orifice installed in the distributor housing. Please refer to the Orifice Metering Device section for selection & installation notes.

TABLE 2: Installed Orifice or TXV Sizes

Indoor Coil Model	Metering Device
F2FV060	Orifice - 90
F3FV060(T)	TXV 0703

TXV Metering Device

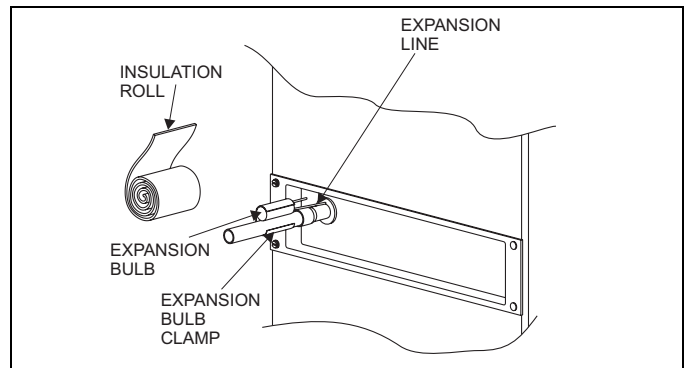

FIGURE 6: TXV Bulb Installation

Please refer to Table 2 to verify which TXV is installed in this Air Handler unit and that this AHU is a valid system match for the AC or HP unit installed.

The TXV is fully brazed into the coil assembly of this Air Handler unit at the factory. The temperature sensing bulb will need to be attached to the coil suction header line after the line set is brazed to the coil.

- Make sure the TXV bulb is outside of the Air Handler cabinet. Excess tubing should remain inside the cabinet.
- Take caution not to apply high temperatures to the TXV assembly or equalizer line while brazing.
- Attach field line sets and braze to coil connections. Replace access panels & secure.
- Secure the TXV bulb to the suction line with the clamp provided. Choose a horizontal location as close to the cabinet as possible, but not directly on the brazed connection joint. Refer to Figure 7.
- The bulb should be in direct contact with the coil suction line along the length of the bulb.
- If the suction line is 3/4" diameter - position the bulb near the top of the copper tube as shown. If the tube is 7/8" diameter - position the bulb near the bottom of the tube. Refer to Figure 7.
- Wrap the clamp, bulb & line securely with insulation provided.

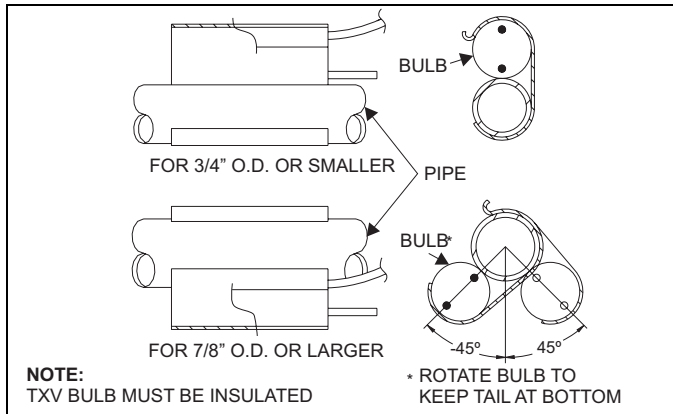

FIGURE 7: Bulb Location

Orifice Metering Device

All non-TXV coils will have an orifice installed in the fitting between the liquid line connection and distributor. See Figure 8. The factory installed orifice is identified on the unit data plate. Also it is listed in Table 2.

The orifice that is shipped with the coil is based on the "most sold" combination, but it may have to be changed, depending on the capacity and efficiency of the outdoor unit, elevation differences of the indoor and outdoor sections, and/or long total line lengths. An additional orifice is shipped with the outdoor unit in the literature packet for most requirements. Other sizes must be ordered from the parts department if required.

Orifice Installation

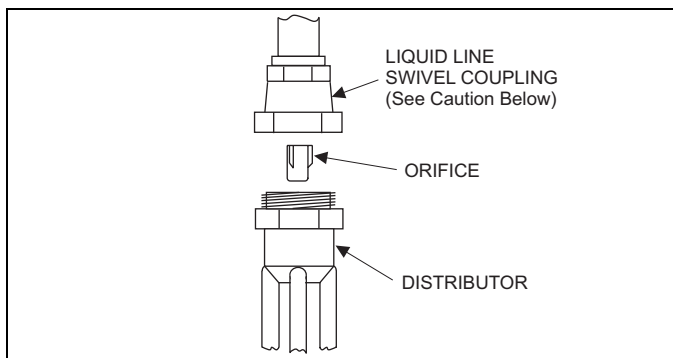

FIGURE 8: Orifice Installation

A standard orifice is pre-installed in the unit and is marked on the unit data plate. Refer to the outdoor unit instruction and application data to determine the proper orifice required for your particular system combination and piping conditions.

If the orifice sizes match, nothing further is required and the refrigerant lines may be connected per the outdoor unit instruction. However, if another orifice should be used, change the orifice in the coil with the following procedure:

WARNING

Coil is under 30 PSIG inert gas pressure. Relieve pressure from schrader valve on liquid line side.

CAUTION

This fitting is a right-hand thread, turn counter-clockwise to remove.

1. Remove the liquid line fitting using 3/4" wrenches, and remove the pre-installed orifice with a small diameter wire or paper clip.
2. Remove the new orifice from the packet and verify that it is the correct number required. Install this orifice with the rounded end toward the coil and the flat end outward per Figure 8.
3. Thread the liquid line fitting back in place on the coil. Tighten the fitting hand tight and turn an additional 1/8 turn to seal.

CAUTION

Use 3/4" wrenches to turn fittings. Using pliers will cause internal damage to the fitting.

- NOTE:** This procedure should be done within 2 minutes to keep air and contaminants from entering the coil. If the orifice cannot be replaced and the coil resealed within 2 minutes, then it should be temporarily closed to air using masking tape (short term delay) or plugging/ capping (long term delay). There is no need to purge the coil if this procedure is done within the time limit.
4. Mark the data plate with the orifice installed.

REFRIGERANT LINE CONNECTION

NOTE: Confirm the orifice size before connecting lines.

See the outdoor unit installation instructions for the procedure to install field supplied tubing for systems with sweat fittings.

Stub adapters are available to adapt sweat connections to quick connections.

Connect lines as follows:

NOTE: Route the refrigerant lines to the coil in a manner that will not obstruct service access to the coil, air handling system or filter.

1. Suction line connections are made outside the center access panel. Cut off the suction line as close to the end as possible. Center access panel is recessed to assure sufficient room for brazing or it can be removed and slid over the suction line during brazing.
2. Braze the suction line. Re-attach the center access panel, if it had been removed.
3. Cut the liquid line at the groove in the bell, removing the schrader fitting.
4. Braze the liquid line.
5. Install supplied grommets on both the suction and liquid lines to complete the air seal.

Lines should be sound isolated by using the appropriate hangers or strapping.

When field supplied lines are used be sure to insulate the suction line only.

ELECTRIC HEATERS & OPERATING CONTROLS

The low voltage transformer and fan / heater control, are standard on all models. See Figure 9. The air handlers are shipped pre-wired to operate as cooling only applications. To complete the installation for cooling only, install the 6-pin jumper plug to the control board to bypass the heater limit controls. This jumper plug is secured to the duct cover near the 4-pin power plug harness. Failure to install the plug will cause the blower to run continuously. (See Figure 9).

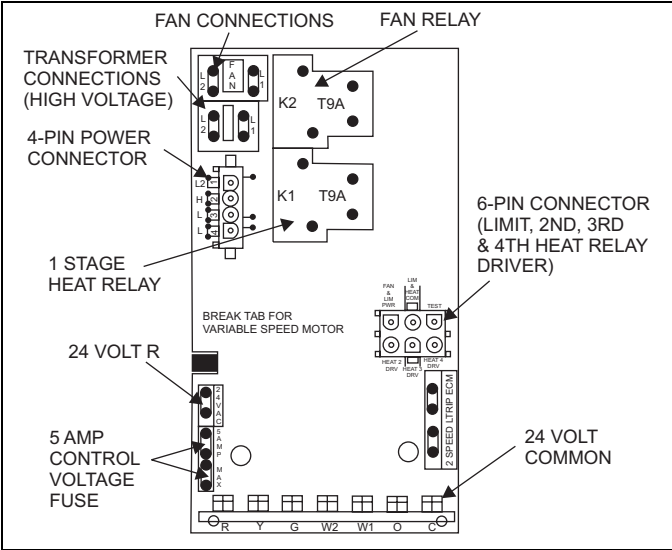

FIGURE 9: Control Board

Mark the unit nameplate with the appropriate heater selection on the space provided or NONE to indicate cooling only. To operate these units with electric heat, it is necessary to field install an electric heater kit (2HK). See Electric Heater Kit Accessory Installation instructions for proper installation procedure. Prior to installing electric heat, it is necessary to perform the following procedure:

1. Remove the 4-pin power plug from the control board (See Figure 9).

NOTE: This pin must not be used when electric heaters are installed.

2. Remove the four (4) screws from the duct cover and remove the duct cover from the air handler.

Right-hand Airflow Application Only - Models with Circuit Breakers - See Figure 10

If unit is to be installed for right hand air flow, the circuit breakers in the heat kit will need to be removed and rotated 180°, so the OFF position will be down when the cabinet is positioned on the right side. This is an NEC requirement. **Do One Set Of Breakers At A Time - to make sure wires are reconnected properly.** Loosen terminal screws on the wires and gently pull the wires back from the breaker. Remove screws securing the breaker plate and rotate 180°, then secure the breaker plate and reconnect the wires to the breaker. Proper torque for terminal screws is 35 in/lbs.

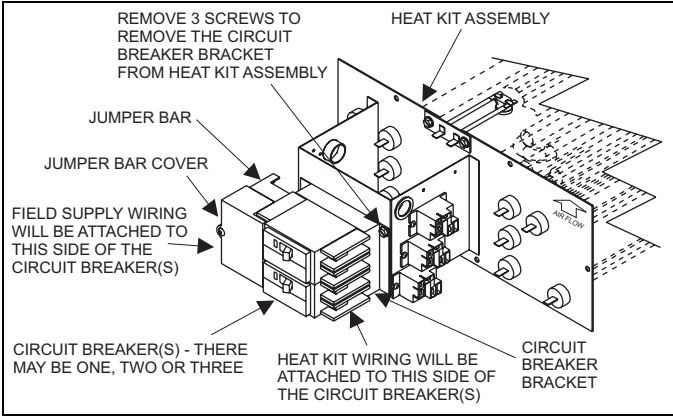

FIGURE 10: Electric Heaters in Horizontal Configuration - Right Hand Air Flow

LOW VOLTAGE CONTROL CONNECTION

The 24 volt power supply is provided by an internally wired low voltage transformer which is standard on all models. However, if the unit is connected to a 208 volt power supply the low voltage transformer must be rewired to the 208 volt tap. See the unit wiring label.

Field supplied low voltage wiring can exit the unit on the top right hand corner or the right hand side panel (See Figure 4, item K).

Install a 7/8" plastic bushing in the selected hole and keep low voltage wiring as short as possible inside the control box.

The field wiring is to be connected at the screw terminals of the control board. Refer to Figures 14, 15 & 16.

NOTE: All wiring must comply with local and national electrical code requirements. Read and heed all unit caution labels.

NOTE: It is possible to vary the amount of electric heat turned on during the defrost cycle of a heat pump. Standard wiring will only bring on 5 KW of electric heat during defrost. See Table 6 and Figures 14, 15 and 16 for alternate staging.

LINE POWER CONNECTIONS

Power may be brought into the unit through the supply air end of the unit (top when unit is vertical) or the left side panel. Use the hole appropriate to the unit's orientation in each installation to bring conduit from the disconnect. The power lead conduit should be terminated at the electrical control box. Refer to Tables 8, 9 & 11 for wire requirements. Also see Figure 11.

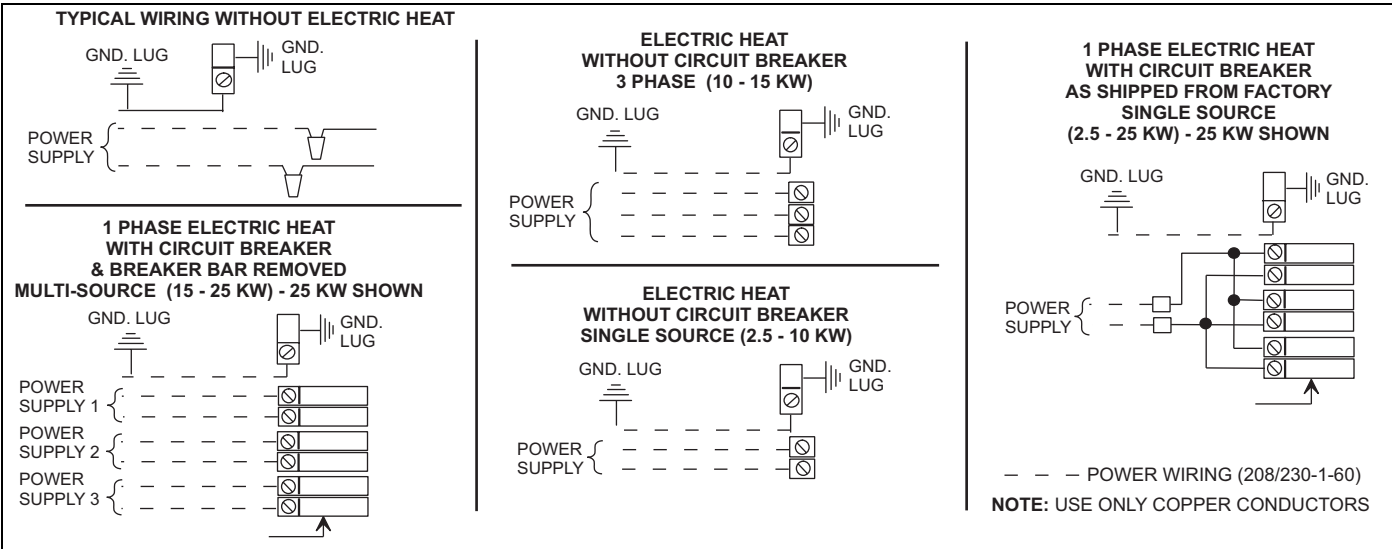

FIGURE 11: Line Power Connections

BLOWER SPEED SELECTION

TABLE 3: CFM / Tap Selection

HIGH SPEED COOLING AND HEAT PUMP CFM		
MODEL	JUMPER SETTING	
F(2,3)FV060	"COOL TAP"	"ADJ TAP"
2100	"A"	"B"
1980	"B"	"B"
1860	"A"	"A"
1750	"B"	"A"
1675	"A"	"C"
1605	"C"	"B"
1575	"B"	"C"
1510	"D"	"B"
1420	"C"	"A"
1335	"D"	"A"
1280	"C"	"C"
1200	"D"	"C"
ELECTRIC HEAT CFM		
MODEL	TAP Selections	
F(2,3)FV060	"HEAT"	
1860	"A"	
1750	"B"	
1420	"C"	
1335	"D"	
DELAY PROFILE		
"DELAY" TAP	UNIT TYPE	
Jumper at "A"	N/A	
Jumper at "B"	Two Stage Condenser	
Jumper at "C"	System with TXV or with Solenoid Valve	
Jumper at "D"	System without TXV or without Solenoid Valve	

NOTE:

- Both the "COOL" and the "ADJ" tap must be set for the cooling CFM.
- Fan only CFM = 63% of high speed cooling.
- Low speed cooling used only with two stage outdoor units. (Speed is preset to 65% of high speed).
- Dehumidification speed is 85% of cooling speed.
- When operating in both heat pump and electric heat modes, the CFM will be whichever is greater.
- CFM indicator light flashes once for every 100 CFM. (i.e.: 12 Flashes is 1200 CFM)

All variable speed air handlers (F(2,3)FV) are designed to deliver constant CFM regardless of the external static pressure (ESP) in the ductwork. Therefore, if too many supply registers are closed, a filter becomes clogged, or there is a restriction in the ductwork, the motor will automatically operate at a higher speed to compensate for the higher ESP. This may result in a higher operating sound level.

All CFM's are shown at 0.5" w.c. external static pressure. These units have variable speed motors that automatically adjust to provide constant CFM from 0.0" to 0.6" w.c. static pressure. From 0.6" to 1.0" static pressure, CFM is reduced by 2% per 0.1" increase in static. Operation on duct systems with greater than 1.0" w.c. external static pressure is not recommended.

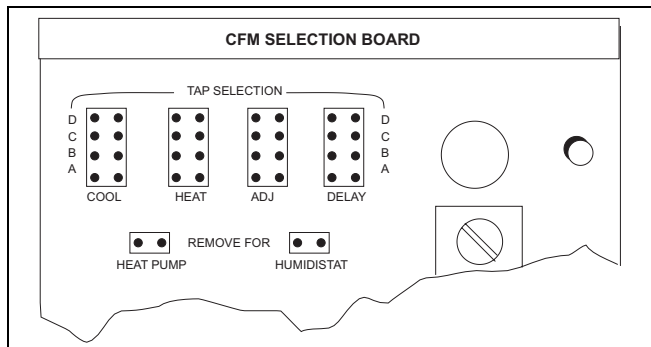

FIGURE 12: CFM Selection Board Detail

To Set Cooling CFM:

Refer to the outdoor unit technical guide for the recommended airflow with the matching evaporator coil. Refer to the label in the bag attached to the blower housing or Table 3 for the possible high speed cooling and heat pump CFM selections.

Find the recommended system airflow in the Table 6 & 7 for the installed Air Handler model.

Select the "COOL" CFM you need from Table 3. Set "COOL" and "ADJ" Jumpers on the CFM selection board as indicated in Table 3.

To Set Heat Pump CFM:

The heat pump CFM setting is the same as the cooling CFM. No additional CFM setting is required, however, you must remove the jumper at the bottom of the connector board labeled "Remove for Heat Pump" for heat pump operation (See Figure 12).

To Set Electric Heat CFM:

The blower speed required for the Electric Heat is different than cooling. Refer to the label in the bag attached to the blower housing or Table 3 for the possible CFM selections. Refer to Tables 6 or 7 for the minimum required CFM for the electric heater installed. Find the desired airflow in Table 3. Set the "Heat" Jumper on the CFM selection board to tap shown.

CAUTION

DO NOT change the "ADJ" tap position on the CFM selection board as this will change your cooling CFM previously selected.

To Set Delay Profile:

Every variable speed air handler has multiple "blower off delay" profiles to optimize system performance and efficiency. Refer to Table 3 or the label in the bag attached to the blower housing for the type of system installed. Set the "DELAY" jumper tap position horizontally on the CFM selection board for the appropriate setting.

Fan Only CFM:

When the connection is made from "R" to "G", the fan only mode is activated. In this mode, the blower will deliver 63% of the cooling system CFM. This connection is factory set from the manufacturer and cannot be field adjusted.

To Install Humidistat Accessory:

If the system is used with a humidistat accessory, connect the field wires to screw terminals "R" and "Hum" on the CFM selection board (See Figures 14, 15 & 16).

IMPORTANT: Remove the jumper at the bottom of the connector board marked "Remove for Humidistat" for humidistat operation.

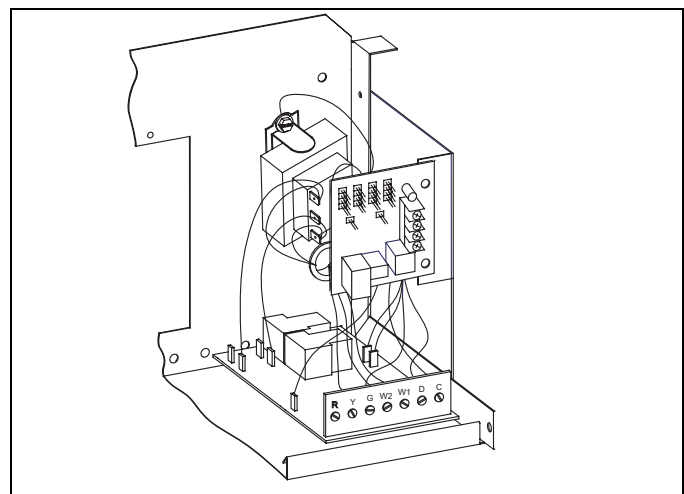

FIGURE 13: Control Box

TABLE 4: Physical and Electrical Data

Models F2FV / F3FV(T)		060
Blower - Diameter x Width		11 x 10
Motor	HP	1.0
	Nominal RPM	1200
Voltage		208 / 230
Amps	Full Load	7.8 / 7.0
	Locked Rotor	-
Filter ¹	Type	Disposable or Permanent
	Size	22 x 20 x 1
	Permanent Type Kit	1PF603BK
Shipping / Operating Weight (lbs.) - FP		160

TABLE 5: Conversion Table

KW & MBH Conversions - for Total Power Input Requirement					
FOR	208V	OPERATION MULTIPLY	240V	TABULATED KW & MBH BY	.751
	230V		240V		.918

TABLE 6: Electrical Data - 1 Ø - 208/230-1-60¹

Models	Heater Model	Max. Static & Min. CFM		Total Heat ²				KW Staging**					
				KW		MBH		W1 Only		W2 Only		W1 + W2	
		Static	Tap	208V	240V	208V	240V	208V	240V	208V	240V	208V	240V
F2FV060H06 F3FV060H06T	2HK*6500806B	0.5	1335	5.6	7.5	19.1	25.6	3.8	5.0	5.6	7.5	5.6	7.5
	2HK*6501006B			7.5	10.0	25.6	34.1	3.8	5.0	7.5	10.0	7.5	10.0
	2HK16501506B			11.3	15.0	38.6	51.2	3.8	5.0	7.5	10.0	11.3	15.0
	2HK16502006B			15.0	20.0	51.2	68.3	3.8	5.0	7.5	10.0	15.0	20.0
	2HK16502506B			18.8	25.0	64.2	85.3	3.8	5.0	11.3	15.0	18.8	25.0

1. Heat amps shown at 240V represents maximum heater rating.

2. See conversion Table 5.

* May be 0 (no breaker) or 1 (with breaker).

** If first stage heat or 66 is connected to W1, otherwise refer to this table.

TABLE 7: Electrical Data - 3 Ø - 208/230-3-60¹

Models	Heater Model	Max. Static & Min. CFM		Total Heat ²				KW Staging**					
				KW		MBH		W1 Only		W2 Only		W1 + W2	
		Static	Tap	208V	240V	208V	240V	208V	240V	208V	240V	208V	240V
F2FV060H06 F3FV060H06T	2HK06501025B	0.5	1335	7.5	10.0	25.6	34.1	3.8	5.0	7.5	10.0	7.5	10.0
	2HK06501525B			11.3	15.0	38.8	51.2	3.8	5.0	7.5	10.0	11.3	15.0

1. Heat amps shown at 240V represents maximum heater rating.

2. See conversion Table 5.

* May be 0 (no breaker) or 1 (with breaker).

** If first stage heat or 66 is connected to W1, otherwise refer to this table.

TABLE 8: Electrical Data - Cooling Only

MODEL	Minimum Circuit Ampacity		ALL VOLTAGES	
	06		Max. O.C.P. ¹ Amps/Type	75°C Wire Size - AWG
	208V	240V		
F2FV060H06 F3FV060H06T	9.7	8.8	15	14

1. OCP = Over Current Protection device, must be HACR type Circuit Breaker or Time Delay fuse.

TABLE 9: Electrical Data - (for Single Source Power Supply) - Copper Wire 208/230-1-60

Model	Heater Model ¹	Heater Amps 240V	Field Wiring					
			Min. Circuit Ampacity		Max. O.C.P. ² Amps/Type		75°C Wire Size - AWG	
			208V	240V	208V	240V	208V	240V
F2FV060H06 F3FV060H06T	2HK*6500806B	31.3	43.8	47.8	45	50	8	8
	2HK*6501006B	41.7	55.2	60.8	60	70	6	4
	2HK16501506B	62.5	78.0	86.9	80	90	4	3
	2HK16502006B	83.3	100.3	112.9	110	125	2	1
	2HK16502506B	104.2	123.1	139.0	125	150	1	1/0

1. May be 0 or 1 (No Breaker or Breaker)
2. O.C.P. = Over-Current Protection device, must be HACR type Circuit Breaker or Time Delay fuse.

TABLE 10: Electrical Data - (for Single Source Power Supply) - Copper Wire 208/230-3-60

Model	Heater Model ¹	Field Wiring					
		Min. Circuit Ampacity		Max. O.C.P. ² Amps/Type		75°C Wire Size - AWG	
		208V	240V	208V	240V	208V	240V
F2FV060H06 F3FV060H06T	2HK06501025B	48.6	52.9	50	60	8	6
	2HK06501525B	48.6	52.9	50	60	8	6

1. May be 0 or 1 (No Breaker or Breaker)
2. O.C.P. = Over-Current Protection device, must be HACR type Circuit Breaker or Time Delay fuse.

TABLE 11: Electrical Data - (for Multi-Source Power Supply) - Copper Wire 208/230-1-60

Model	Heater Model	Min. Circuit Ampacity			Max. O.C.P. ¹ Amps/Type			75°C Wire Size - AWG		
		Circuit			Circuit			Circuit		
		1st	2nd	3rd	1st	2nd	3rd	1st	2nd	3rd
		208/240V	208/240V	208/240V	208/240V	208/240V	208/240V	208/240V	208/240V	208/240V
F2FV060H06 F3FV060H06T	2HK16501506B	33.0/34.8	45.1/52.1	-	35/35	50/60	-	8/8	8/6	-
	2HK16502006B	55.2/60.8	45.1/52.1	-	60/70	50/60	-	6/4	8/6	-
	2HK16502506B	33.2/34.8	45.1/52.1	45.1/52.1	35/35	50/60	50/60	8/8	8/6	8/6

1. O.C.P. = Over Current Protection device, must be HACR type Circuit Breaker or Time Delay fuse..

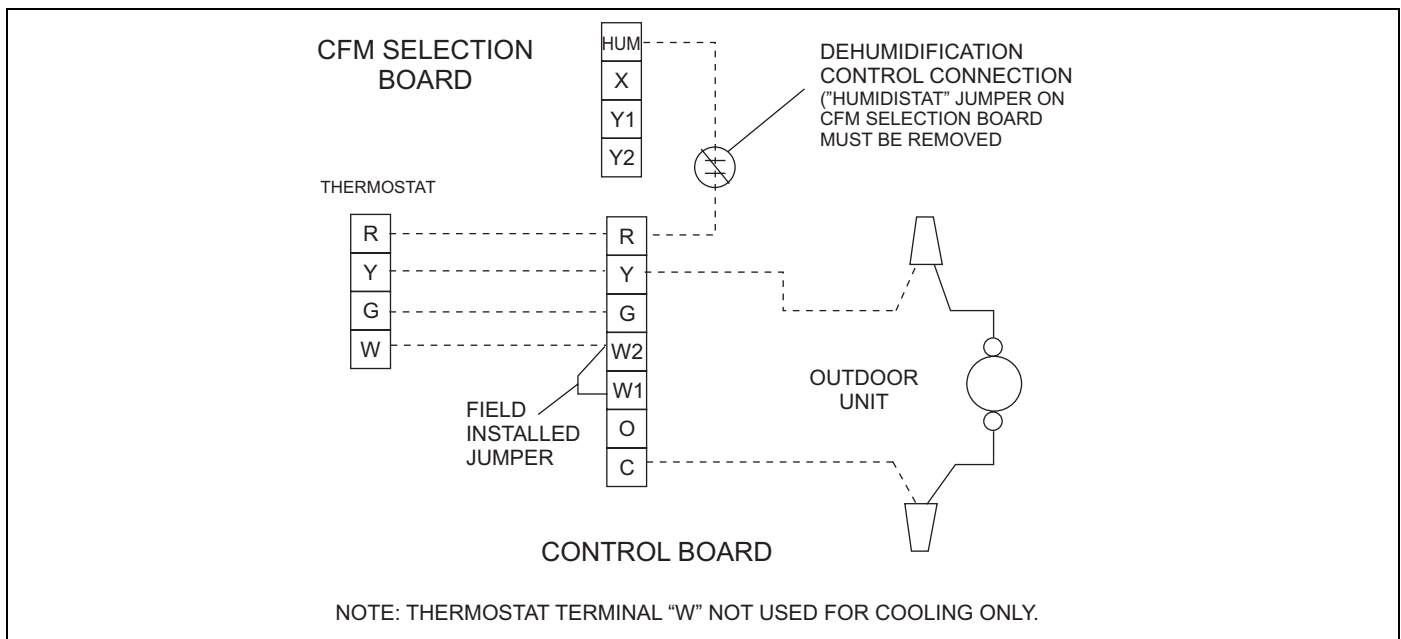

FIGURE 14: Cooling Models with Electric Heat Wiring

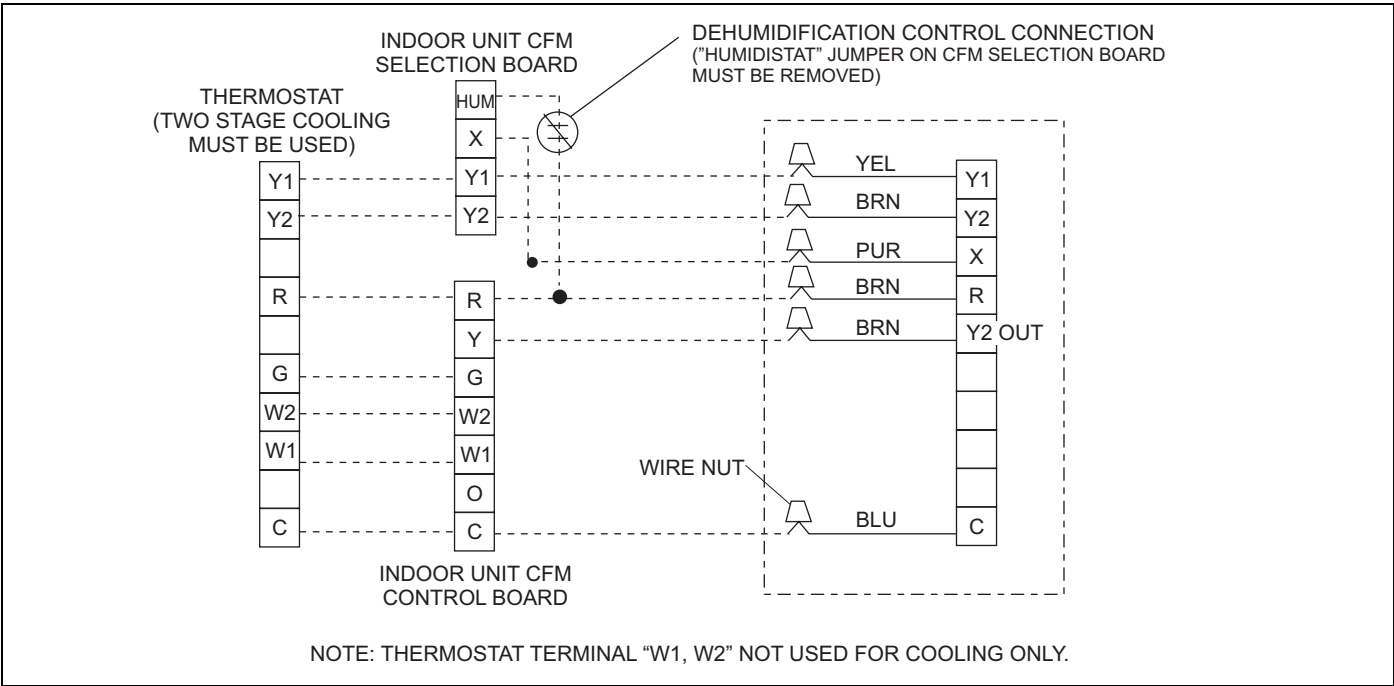

FIGURE 15: Two-Stage Cooling Wiring

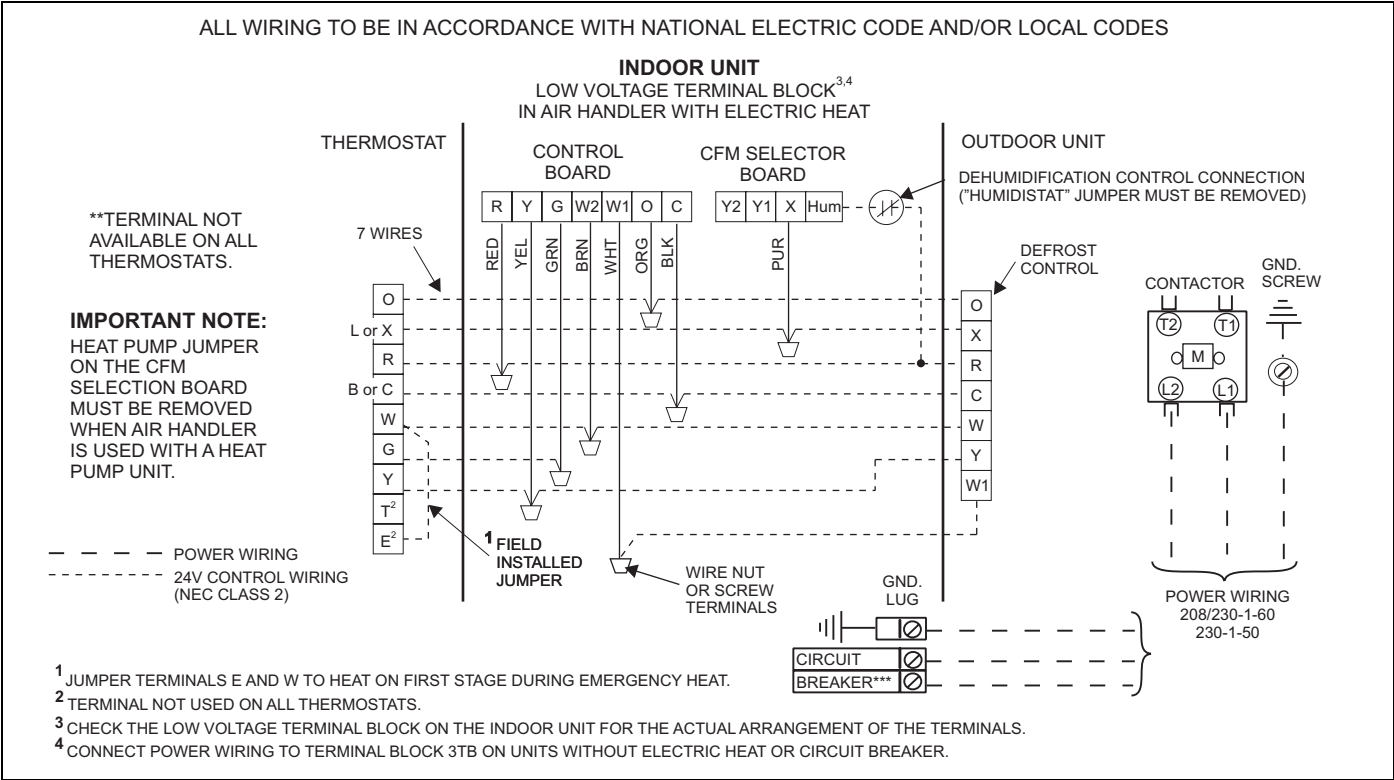

FIGURE 16: Heat Pump Wiring

DRAIN CONNECTIONS

All drain lines should be trapped a minimum of three inches, should be pitched away from unit drain pan and should be no smaller than the coil drain connection.

CAUTION

Threaded drain connection should be hand-tightened, plus no more than 1/16 turn.

CAUTION

Horizontal drain cutout in the center access panel should be removed by using a utility knife. DO NOT TRY TO KNOCK OUT.

Route the drain line so that it does not interfere with accessibility to the coil, air handling system or filter and will not be exposed to freezing temperatures. See Figures 2, 3 and 4.

NOTE: When the coil is installed in an attic or above a finished ceiling, an auxiliary drain pan should be provided under the coil as is specified by most local building codes.

Coils should be installed level or pitched slightly toward the drain end. Suggested pitch should not exceed 1/4 inch per foot of coil.

The coil is provided with a secondary drain that should be trapped and piped to a location that will give the occupant a visual warning that the primary drain is clogged. If the secondary drain is not used it must be capped.

The drain pan connections are designed to ASTM Standard D 2466 Schedule 40. Use 3/4" PVC or steel threaded pipe. Since the drains are not subject to any pressure it is not necessary to use Schedule 40 pipe for drain lines.

It is recommended that all drain connections be sealed with teflon tape or equivalent.

MAINTENANCE

Filters must be cleaned or replaced when they become dirty. Inspect at least once per month. The frequency of cleaning depends upon the hours of operation and the local atmospheric conditions. Clean filters keep unit efficiency high.

COIL CLEANING

If the coil needs to be cleaned or replaced, it should be washed with Calgon coilclean (mix one part Coilclean to seven parts water). Allow solution to remain on coil for 30 minutes before rinsing with clean water. Solution should not be permitted to come in contact with painted surfaces.

LUBRICATION

The bearings of the blower motor are permanently lubricated.

CONDENSATE DRAINS

During the cooling season check the condensate drain lines to be sure that condensate is flowing from the primary drain but not from the secondary drain. If condensate ever flows from the secondary drain the unit should be promptly shut off and the condensate pan and drains cleaned to insure a free flowing primary drain.

TROUBLESHOOTING GUIDE

PROBLEM	POSSIBLE CAUSE
Blower Runs all of the time	<ol style="list-style-type: none"> 1. No heat units do not have 6-pin connector installed. 2. Limit open or not connected. 3. Blower OFF delay (approx. 1 min). 4. Thermostat fan switch in "ON" position.
Blown Fuse	<ol style="list-style-type: none"> 1. Low voltage short to C or ground from R, Y, G, W, or O.
No 24V	<ol style="list-style-type: none"> 1. 4-pin connector loose. 2. Loose wire from control to transformer (24V and 230V). 3. Blown fuse on control board.
No 2nd stage heat	<ol style="list-style-type: none"> 1. Check 6-pin connector and connections to panel mount relays. 2. Verify that both W₁ & W₂ are connected at the terminal strip.
No Heat or Limited Heating	<ol style="list-style-type: none"> 1. Check filter. 2. Closed registers. 3. Restricted airflow (supply registers or return registers) 4. Check blower motor operation. 5. If the safety limit opens 4 times, the control will not permit the heating element to operate for 1 hour.