

# ACCESSORY KIT INSTALLATION INSTRUCTIONS

## OUTDOOR THERMOSTAT 3024-6881/D and 3024-7881/D FOR USE IN THE FOLLOWING MODELS: X3 HEAT PUMPS

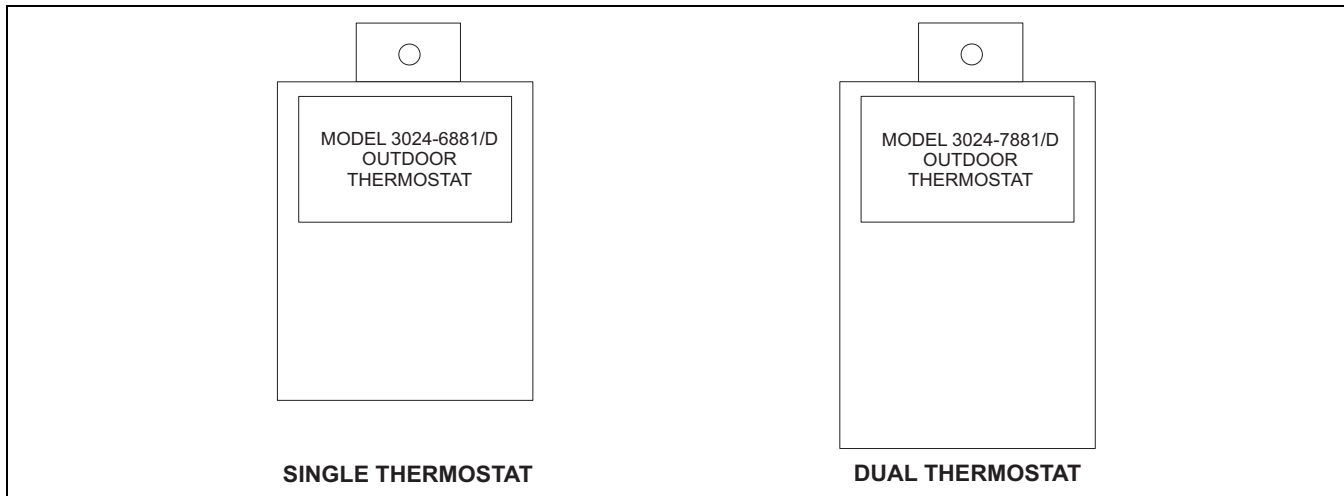

**IMPORTANT** - These instructions are intended for the use of qualified individuals specially trained and experienced in installation of this type of equipment and related system components.

### **WARNING**

*Improper installation may damage equipment, can create a shock hazard, and will void the warranty.*

**NOTE:** The words “Shall” or “Must” indicate a requirement which is essential to satisfactory and safe product performance.

The words “Should” or “May” indicate a recommendation or advice which is not essential and not required but which may be useful or helpful.

Installation and service personnel are required by some states to be licensed.

Persons not qualified shall not install this equipment or interpret these instructions.

### APPLICATION

The single thermostat is used with systems having 5 - 10 KW electric heat. The dual thermostat is used with systems having 15KW or, more electric heat. The function of the outdoor thermostat accessory is to prevent the use of unneeded auxiliary electric heat when the heat pump capacity is sufficient to meet the home heating requirement, thus saving energy and utility costs. Note that the auxiliary electric heat operates in response to the second stage of the wall thermostat, and that the outdoor thermostat(s) is wired in series with the second stage. When adjusted to the correct setting(s), the outdoor thermostat(s) prevents the operation of the auxiliary electric heat at temperatures above the setting(s).

Through the contacts of the emergency heat relay, located in the outdoor thermostat accessory, the outdoor thermostat(s) are by-passed, placing the control of the electric heat solely in response of the wall thermostat's second stage.

**The emergency heat relay is energized by one of the following occurrences:**

- The system switch of the wall thermostat is placed in the “emergency heat” position.
- The system's compressor is locked out due to a high temperature or a high pressure limit tripping action.

The setting(s) of the outdoor thermostat(s) is described in a later section of these instructions.

### INSTALLATION

### **WARNING**

**SHOCK HAZARD** - *Disconnect electric power to equipment before installation to prevent equipment damage and possible personal injury.*

### LOCATION

This accessory is designed to be installed in an outdoor environment. However, constant shade is the determining factor in selecting a location for the outdoor thermostat. Radiant heat from direct rays of the sun could affect the operation of the thermostat.

There may be some heat pump models that provide an attachment location for the outdoor thermostat, most models do not. Careful selection should be used in locating the outdoor thermostat. The electric cable provided is long enough to allow the thermostat to be mounted on a nearby structure.

**WIRING**

Route the electrical cable through the low voltage hole provided in the outdoor heat pump.

Connect the cable wiring per the wiring diagram that pertains to the application as listed below.

Use Figure 1 for typical residential installation with single stage outdoor thermostat.

Use Figure 2 for typical residential installation with dual stage outdoor thermostat.

Use Figure 3 for typical manufactured housing installation with single stage outdoor thermostat.

Use Figure 4 for typical manufactured housing installation with dual stage outdoor thermostat.

Use Figure 5 for packaged heat pump with single stage outdoor thermostat.

Use Figure 6 for packaged heat pump with dual stage outdoor thermostat.

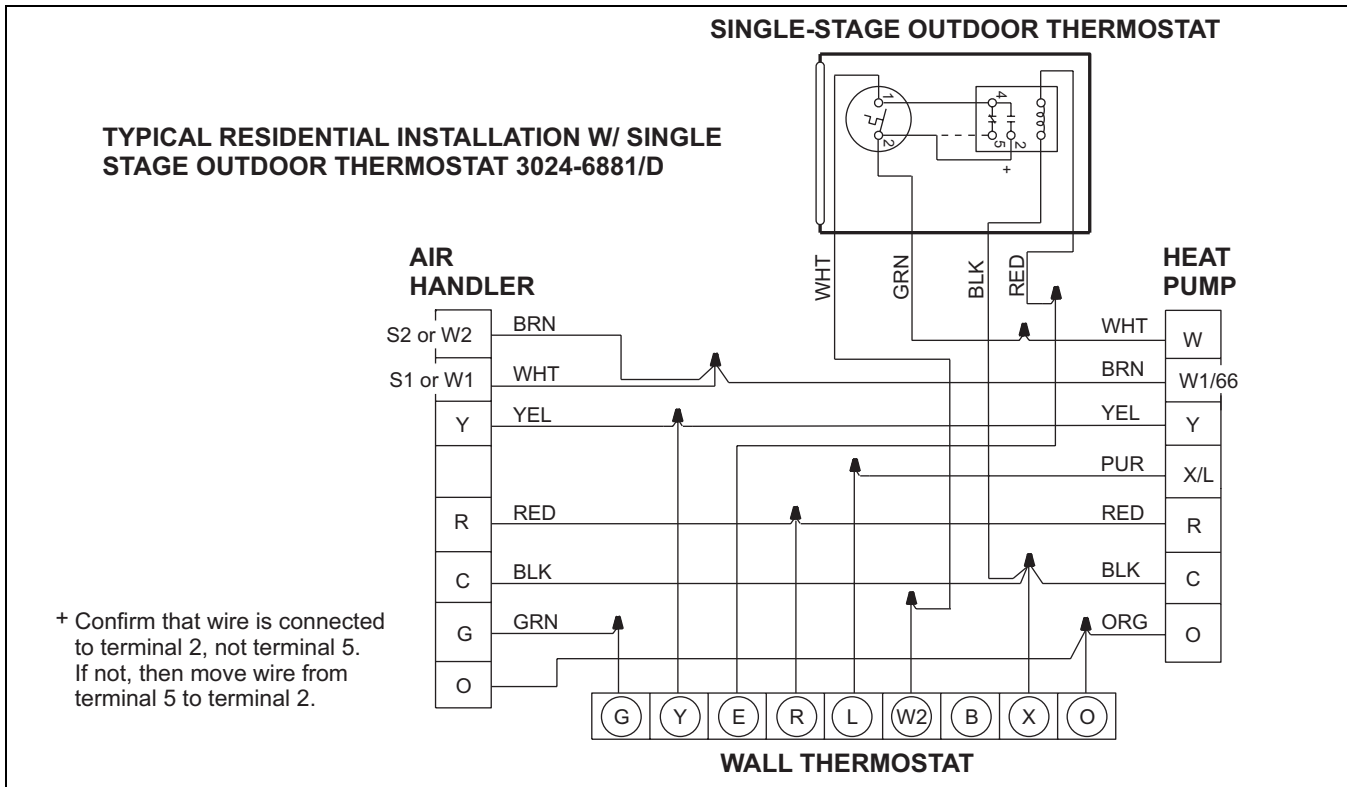

**FIGURE 1:** Wiring Connections for Typical Residential Installation with Single Stage Outdoor Thermostat

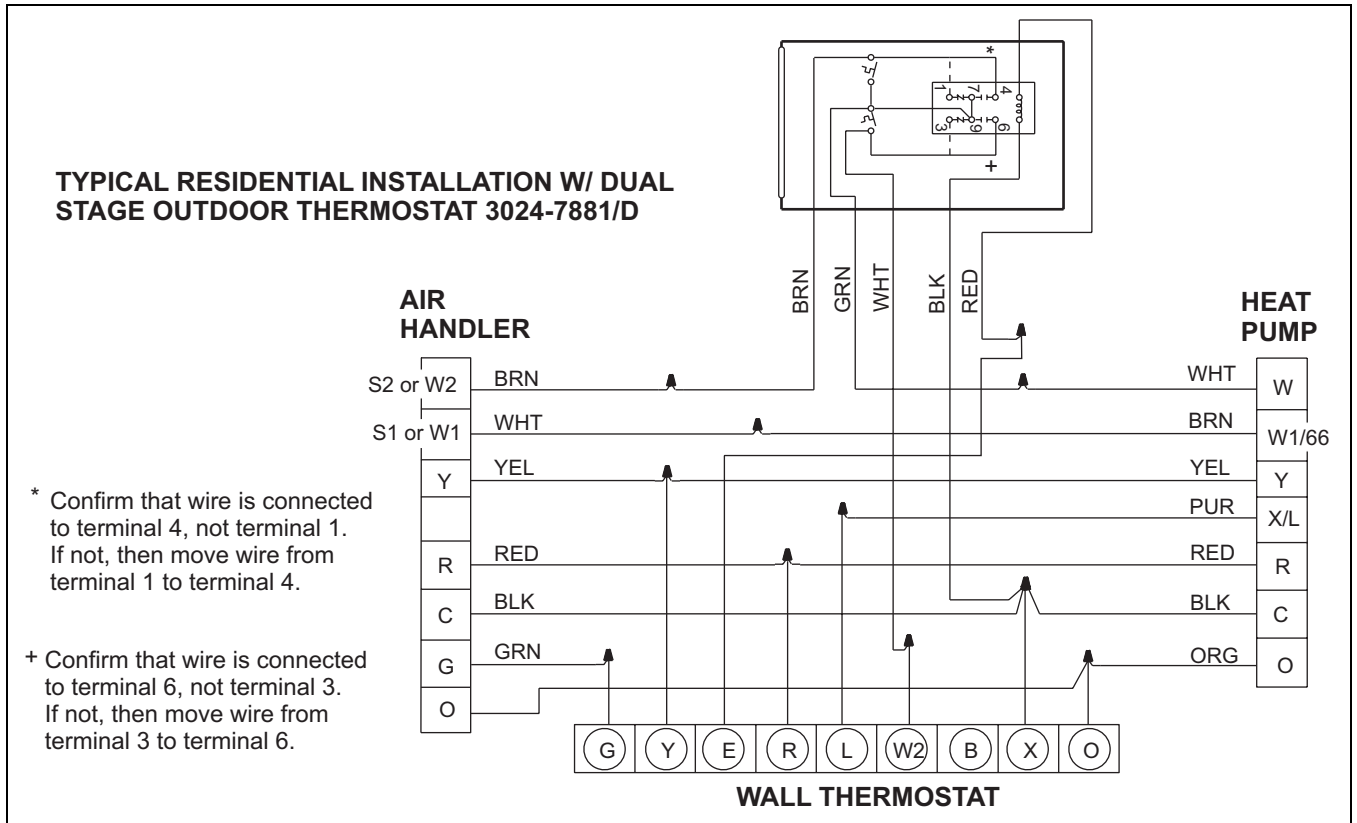

**FIGURE 2:** Wiring Connections for Typical Residential Installation with Dual Stage Outdoor Thermostat

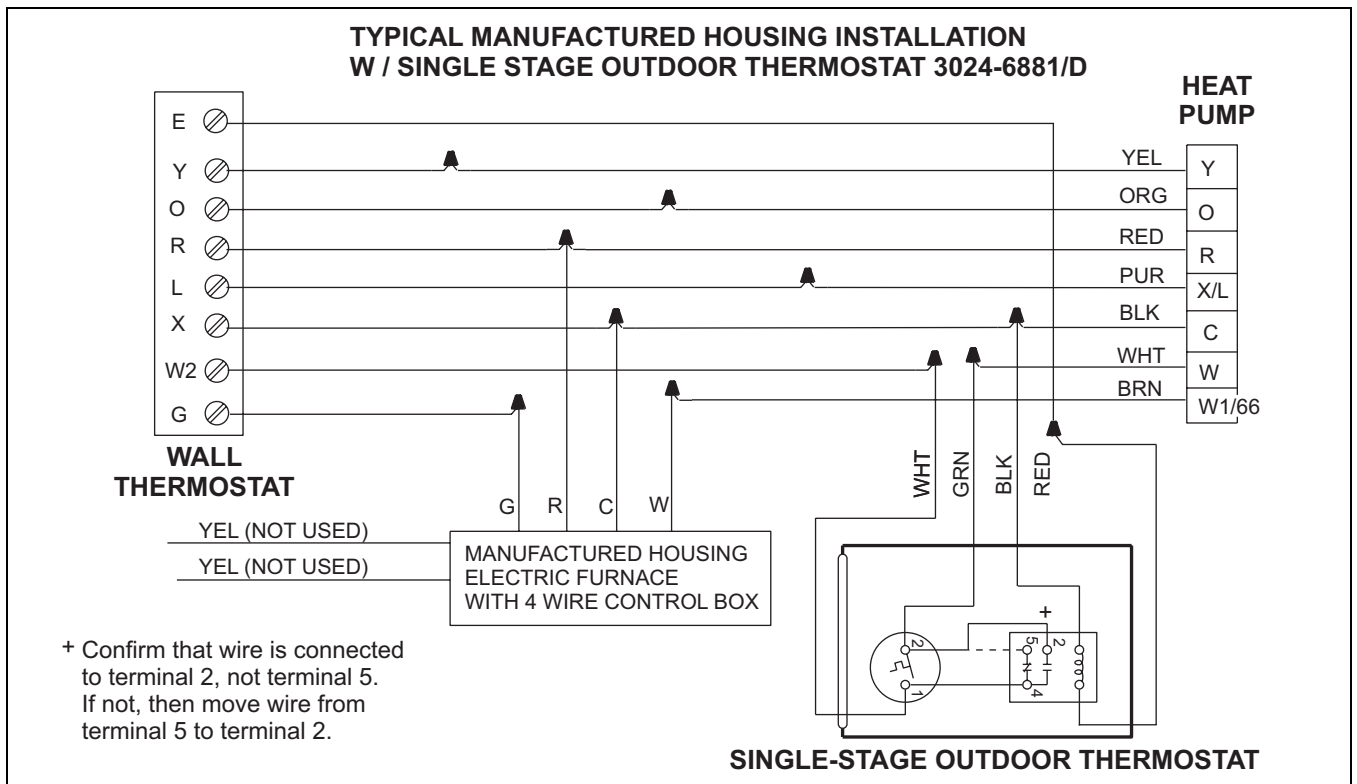

**FIGURE 3:** Wiring Connections for Typical Manufactured Housing Installation with Single Stage Outdoor Thermostat

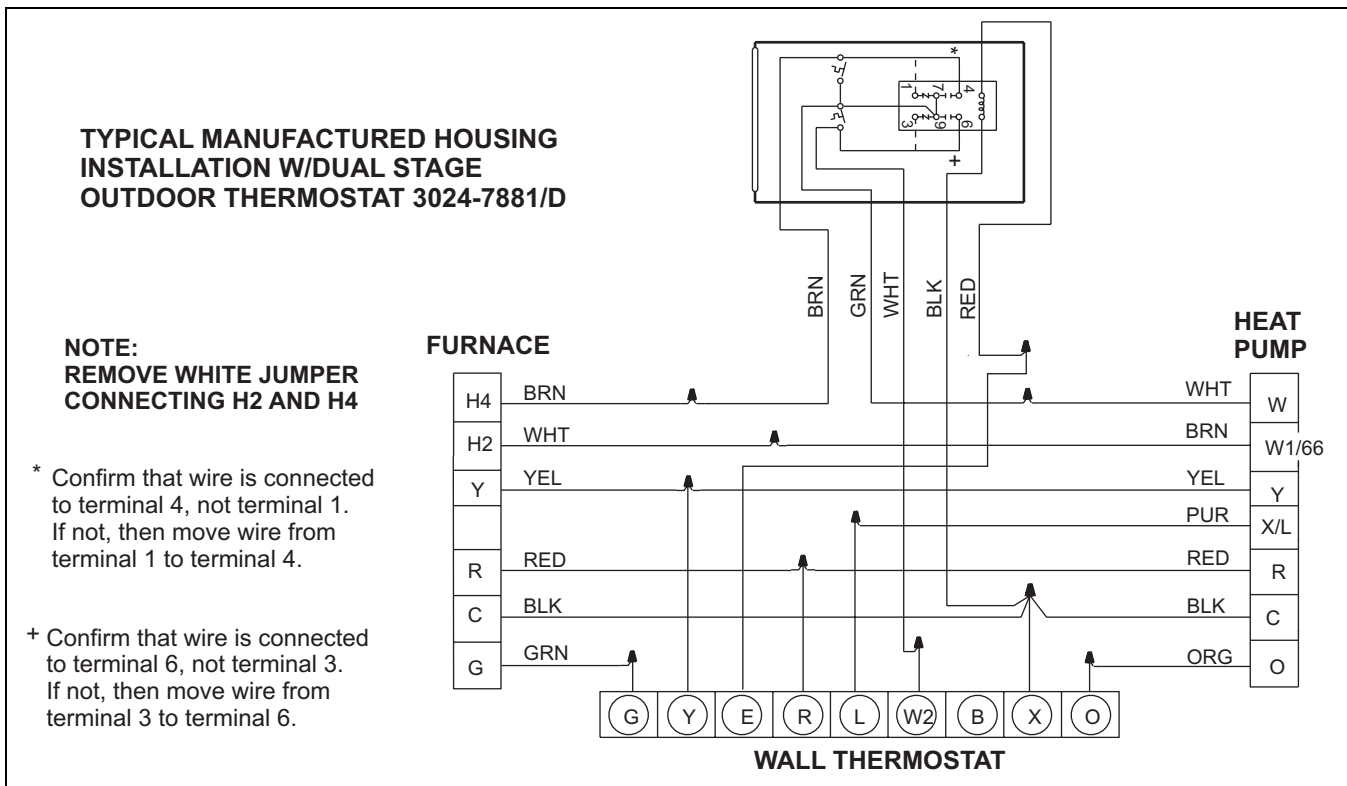

**FIGURE 4:** Wiring Connections for Typical Manufactured Housing Installation with Dual Stage Outdoor Thermostat

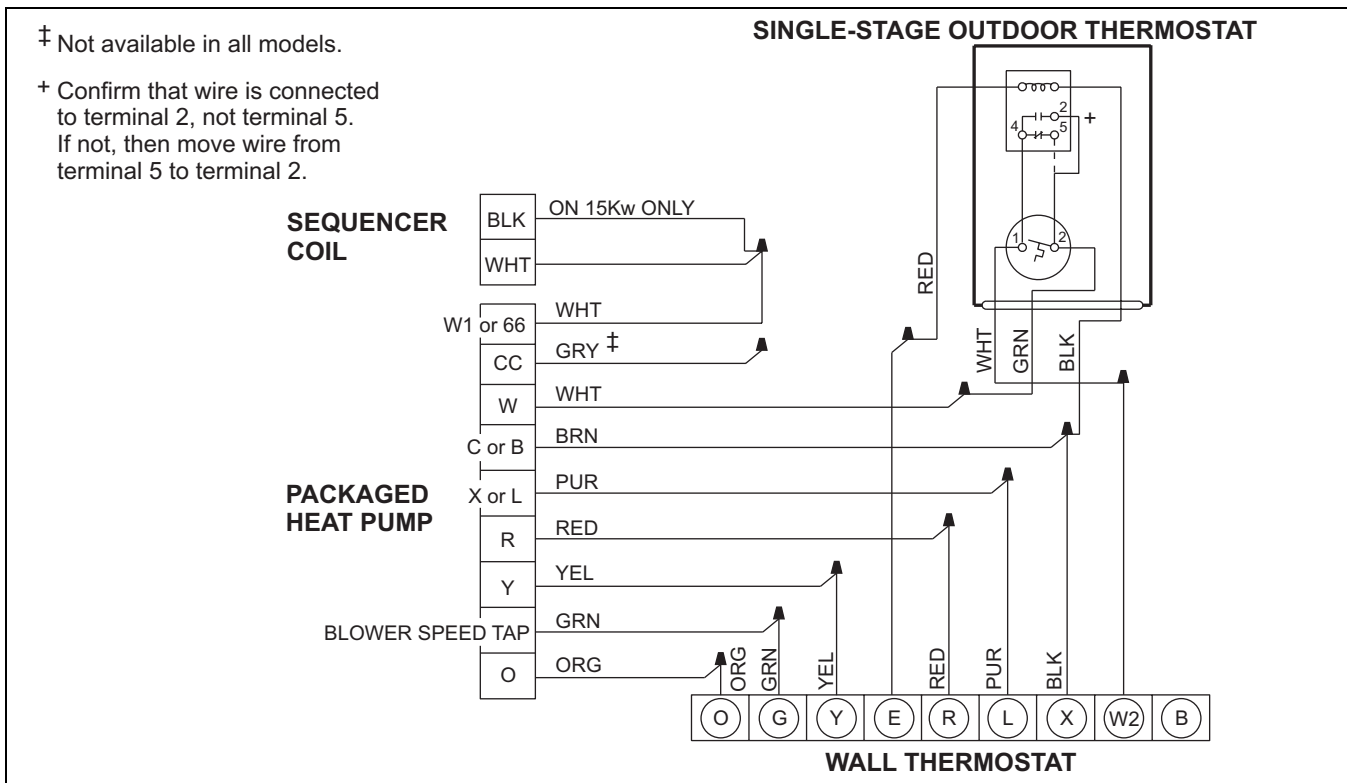

**FIGURE 5:** Wiring Connections for JP/PHP Packaged Heat Pump with Single Stage Outdoor Thermostat

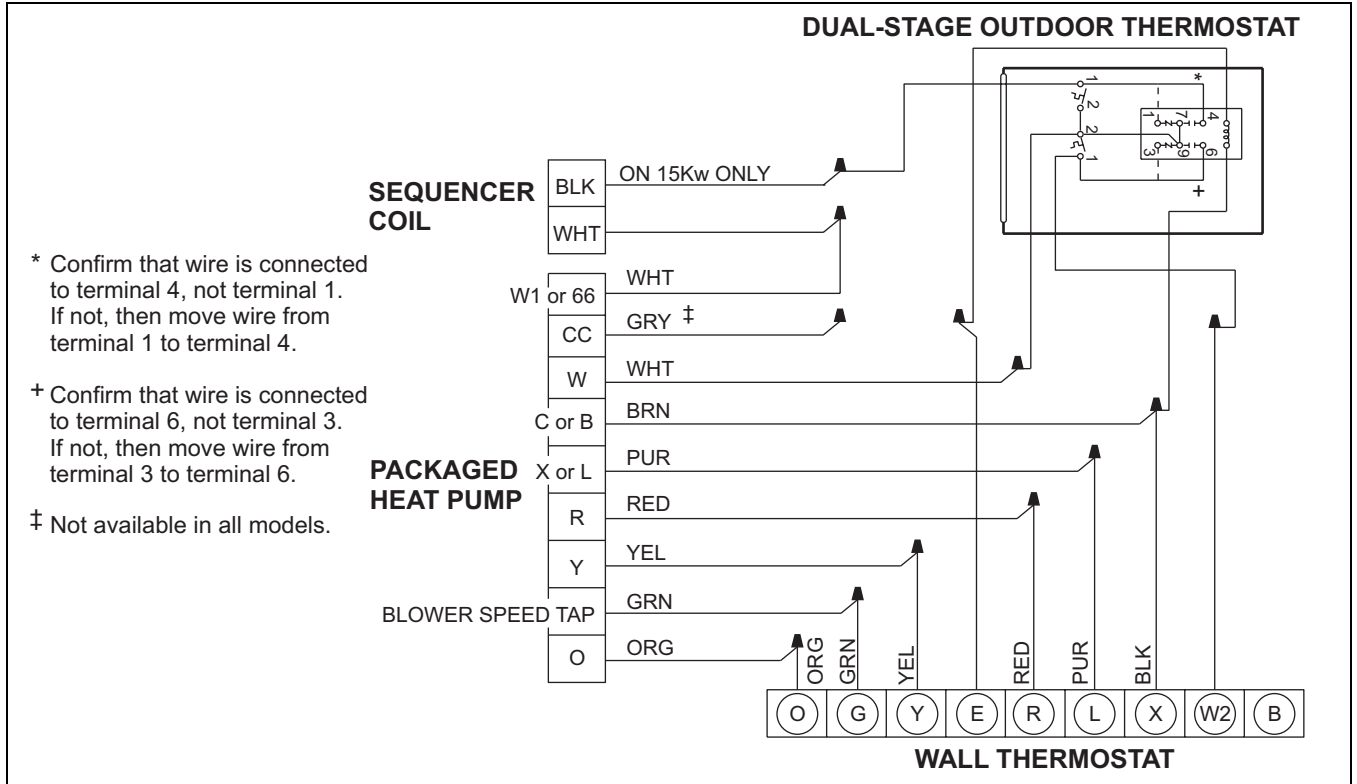

**FIGURE 6:** Wiring Connections for JP/PHP Packaged Heat Pump with Dual Stage Outdoor Thermostat

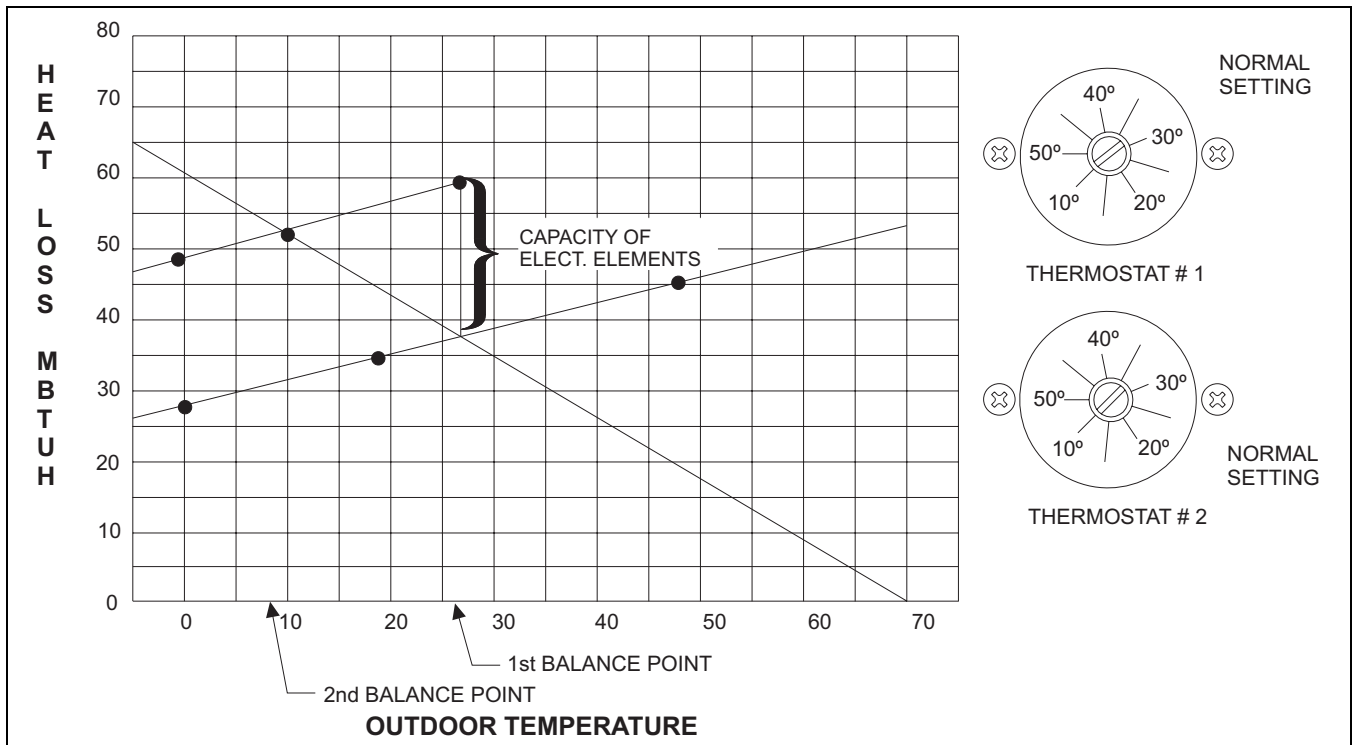

**FIGURE 7:** Balance Point Determination Chart

## OUTDOOR THERMOSTAT(S) BALANCE POINT TEMPERATURE ADJUSTMENT FOR THE HOME

### Determine the first balance point:

Before setting the outdoor thermostat, a heat loss calculation must be made of the home. The heat loss of a home is assumed to be linear and inversely proportionate to the outdoor temperature. As the outdoor temperature drops, the heat loss of the home increases. Conversely the heat pump capacity is reduced as the outdoor temperature drops. At some outdoor temperature, the heat pump capacity will balance with the home's heat loss. In other words, at that point, the heat loss of the home will be identical to the amount of heat produced by the heat pump.

In order to determine the exact balance point, it is necessary to chart the heat loss against the capacity of the heat pump. See the heat pump Tabular Data Sheet for capacity information at various outdoor temperatures. Chart the capacities of the heat pump at the corresponding outdoor temperatures on a graph and connect the points. See Figure 7. The vertical axis represents BTU's (in thousands) and the horizontal axis represents outdoor temperature.

For the purpose of this example, let us assume that the calculated heat loss of the home is 50,800 BTU's per hour at an outdoor design temperature of + 10° F. Moving up the vertical axis, at 10° F, locate the number of BTU's per hour heat loss and mark that point on the graph. Placing a straight edge on this point, and aligning with the 70° F (the normal indoor comfort condition) in the lower right-hand corner, connect these two points with a straight line. Locate the point at which the heat loss crosses the capacity curve of the heat pump. This intersection is the balance point temperature for the example application. This is the only balance point needed for applying the single thermostat model and is the first balance point when applying the dual thermostat model.

### Determining the second balance point:

On the vertical axis at the first balance point, add 22,000 BTU's which is the capacity of the electrical heating elements, and mark this point. This represents the combined capacity of the heat pump and the electric elements. From this point draw a line parallel to the heat pump capacity curve. Where this new line intersects the heat loss line is the second balance point.

### Remove the outdoor thermostat cover, and set thermostat(s):

It is advisable to set the thermostat(s) 3 degrees above the determined balance point(s) so that the thermostat(s) are closed before the wall thermostat's second stage calls for heat. The outdoor thermostats are factory set at 30 degrees (for the single thermostat model and #1 thermostat on the dual thermostat model.) and 20 degrees (for the #2 thermostat on the dual thermostat model.) For this example, adjust the #1 thermostat by aligning the screw slot on 32 degrees, adjust the #2 thermostat so that the screw slot aligns with 10 degrees. Replace cover.

## NOTES

---

## NOTES

Subject to change without notice. Printed in U.S.A.  
Copyright © by York International Corp. 2007. All rights reserved.

18624-UAI-G-0707  
Supersedes: 18624-UAI-F-0506

---

**Unitary  
Product  
Group**

**5005  
York  
Drive**

**Norman  
OK  
73069**