

ACCESSORY KIT INSTALLATION MANUAL

THERMAL EXPANSION VALVE KITS

**FOR R-22 1TV0701, 1TV0702, 1TV0703 1TV0704, 1TV0705 AND 1TV0706
FOR R-410A 1TV0901, 1TV0902, 1TV0903, 1TV0904, 1TV0905, AND 1TV0906
FOR MODELS G2FD, G1NA, G1HD, G1FA, G1HA, G1UA AND F2RC/RP/FP/FC**

GENERAL

This thermal expansion valve (with internal check valve) is to be used with outdoor units having hard start capability. This kit may also be used to provide overall system performance improvement. The kit can be applied to G2FD, G1NA, G1HD, G1FA, G1HA and G1UA indoor coils and F2RC/RP/FP/FC, both for heat pump and cooling applications.

The kit consists of a bolt-on thermal expansion valve, 2.5 feet of thermal insulation, bulb straps or bulb clamp and this instruction.

When a TXV kit is installed on systems using reciprocating compressors, a hard start kit must be installed. Hard start kits are not necessary on units using scroll compressors.

Refer to Tabular Data sheet for specific model TXV/match-up.

- 1TV0700 series TXV kits are R-22 AC and HP.
- 1TV0900 series TXV kits are for R-410A AC and HP.

INSTALLATION

To install the thermal expansion valve, use the following steps.

1. Relieve the holding charge by depressing the Schrader valve located in the end of the liquid line of the coil.

WARNING

ID coil is under 30 psig pressure.

2. After holding charge is completely discharged, loosen and remove the liquid line fitting from the orifice distributor assembly. Note that the fitting has right hand threads.
3. Remove the orifice from the distributor body using a small diameter wire or paper clip. Orifice is not to be used when the TXV assembly is installed.
4. After orifice is removed, install the thermal expansion valve to the orifice distributor assembly with supplied fittings. Orient the TXV as shown in Figure 1. Hand tighten and turn an additional 1/8 turn to seal. Do not overtighten fittings.

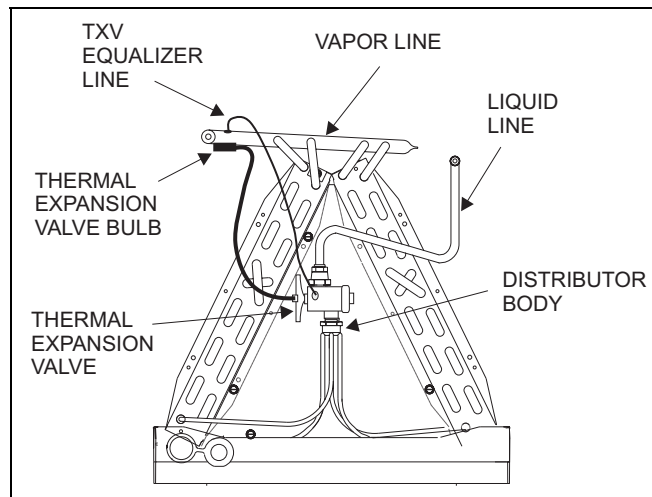

FIGURE 1: Kit Installation in System (Single Piece Air Handler Installation Shown)

5. Reinstall the liquid line to the top of the thermal expansion valve. Hand modify the liquid line to align with casing opening.
6. Install the TXV equalizer line into the vapor line as follows:
 - a. Select a location on the vapor line for insertion of the equalizer line which will not interfere with TXV bulb placement.
 - b. Use an awl to punch through the vapor line and insert the awl to a depth to achieve a 1/8" diameter hole.
7. Install TXV equalizer line in 1/8" hole previously made in vapor line. Equalizer line can be bottomed out in vapor line as end of equalizer line is cut on 45 degree angle to prevent blockage. Braze equalizer line making sure that tube opening is not brazed closed.

CAUTION

Dry nitrogen should always be supplied through the tubing while it is being brazed, because the temperature is high enough to cause oxidation of the copper unless an inert atmosphere is provided. The flow of dry nitrogen should continue until the joint has cooled. Always use a pressure regulator and safety valve to insure that only low pressure dry nitrogen is introduced into the tubing. Only a small flow is necessary to displace air and prevent oxidation.

All connections to be brazed are copper-to-copper and should be brazed with a phosphorous-copper alloy material such as Silfos-5 or equivalent. DO NOT use soft solder.

Nitrogen can be introduced through the Schrader access (located at the OD unit connection of the refrigerant line). The Schrader core can be removed before connecting the source of nitrogen, but should be reinstalled prior to the evacuation and charging of the refrigerant lines and ID coil.

8. Leak check refrigerant lines and indoor coil connections. If leak free, remove leak check charge, reinstall any Schrader cores that were removed and evacuate refrigerant lines and ID coil. Evacuate through the Schrader access valves of the liquid and vapor service valves on OD unit.

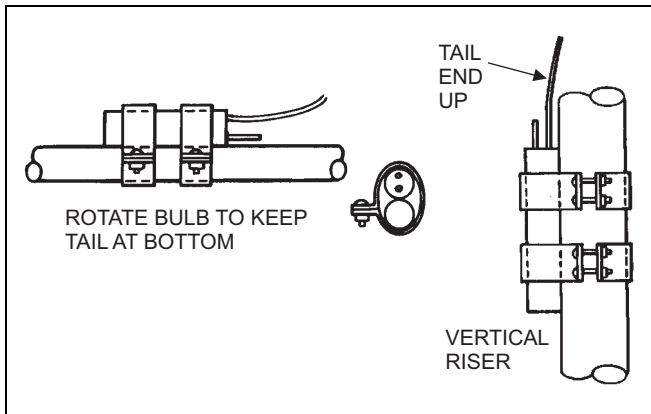

FIGURE 2: Correct Bulb Locations

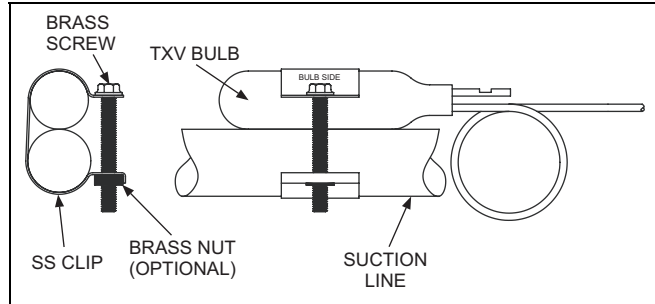

FIGURE 3: Clamp Attachment for 1TV0705 & 1TV0706

9. Install the TXV bulb to the vapor line near the equalizer line, using the bulb clamp(s) furnished with the TXV assembly. Ensure the bulb is making maximum contact. See Figure 2 for proper bulb location. See Figure 3 for clamp assembly on 1TV0705 and 1TV0706.

CAUTION

In all cases, mount the TXV bulb after vapor line is brazed and has had sufficient time to cool.

- a. Bulb should be installed on a horizontal run of the vapor line if possible. The bulb should be installed on top of the line.
 - b. If bulb installation is made on a vertical run, the bulb should be located at least 16 inches from any bend, and on the tubing sides opposite the plane of the bend. The bulb should be positioned with the bulb tail at the top, so that the bulb acts as a reservoir.
 - c. Bulb should be insulated using thermal insulation provided to protect it from the effect of the surrounding ambient temperature.
10. After the interconnecting refrigerant lines, TXV assembly and ID coil have been evacuated, the liquid and vapor line valves at the OD unit can be opened to release the refrigerant charge into the complete system. The proper procedure for opening these valves is covered in the OD unit installation instructions.
 11. The OD unit factory refrigerant charge includes the charge for 15 feet of interconnecting vapor and liquid lines. If interconnecting lines are longer than 15 feet, additional charge must be added for the length. The OD unit installation instructions list the charge required per foot of liquid/vapor lines. Also, some indoor coil matches may require additional charge. This charge is also listed in the OD unit installation instruction. The additional charge should be introduced into the system by means of a calibrated charging cylinder or other means of accurately weighing the refrigerant.