

INSTALLATION INSTRUCTION

LOW AMBIENT CONTROL REPLACEMENT KIT MODEL 2LA04700824

GENERAL

This kit is designed to regulate condenser head pressure at low ambients by varying the amount of airflow through the condenser. It helps ensure sufficient pressure differential across the expansion device and prevents downtime.

▲WARNING

Improper installation, adjustment service, or maintenance can cause injury or property damage; therefore, only a qualified installer or qualified service personnel should perform this conversion.

INSPECTION

The following list details the parts included in this kit. Inspect the kit to ensure that all listed parts are included.

TABLE 1: CONTENTS OF KIT

ITEM	QTY	PART NO.	DESCRIPTION
1	1	448542	Low Ambient Control - LAC (Includes mounting screws, tape and temperature probe)
2	1	10766	Kit Instruction Form
3	1	AB020BLU7171700	Wire, 700/BLU [from LAC (600 VAC or 120/240 VAC)]
4	1	AB022BLK7171701	Wire, 701/BLK [from LAC (Line 2) to M1 (T1)]
5	1	AB020YEL7171808	Wire, 808/YEL [from LAC (24V) to M1 (COIL A)]
6	1	AB022BRN7157809	Wire, 809/BRN [from LAC (24V) to M1 (COIL B)]
7	1	10828	Wiring Diagrams (208/230-1-60 supply voltage)
8	1	10829	Wiring Diagrams (230-3-60 supply voltage)
9	1	10830	Wiring Diagrams (460/575-3-60 supply voltage)

TOOLS REQUIRED FOR INSTALLATION

The following list details the tools needed to install this kit. These tools are not supplied with this kit and must be supplied at time of installation.

TABLE 2: REQUIRED TOOLS

ITEM	QTY.	DESCRIPTION
1	1	Hex Nut Driver, 5/16"
2	1	Phillips Head Screw Driver, #2
3	1	Slip Joint Pliers

INSTALLATION

Install the timer accessory as follows:

▲WARNING

Make sure both the gas and electric power are shut-off. Failure to disconnect the electric power could result in electrical shock or severe injury from the outdoor fan.

1. Disconnect all electrical power to the unit.
2. Use the 5/16 inch nut driver to remove the control access panel and the condenser panel from the front of the unit.
3. Use the #2 phillips head screw driver and the 4 screws provided with the low ambient control and attach the control in the control compartment to the right hand side partition in the holes provided. See Figure 1.

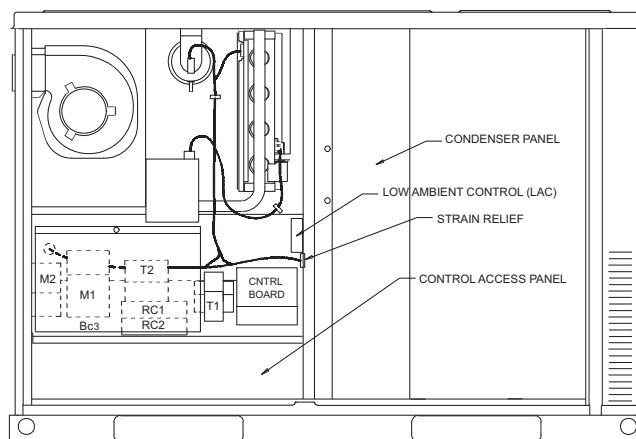

FIGURE 1 - FRONT VIEW OF UNIT

4. Based on the unit voltage, select the proper wiring diagram and attach it to the inside of the control access panel. See the contents of kit table to select the correct wiring diagram.
5. Wire the control as follows (Refer to the wiring diagram as needed);
 - a. Remove the BLK condenser fan motor wire from M1 (T1) and connect to LAC (Motor 2).
 - b. Connect the 701/BLK wire from LAC (Line 2) to M1 (T1).
 - c. Connect the 808/YEL wire from LAC (24V) to M1 (COIL A).
 - d. Connect the 809/BRN wire from LAC (24V) to M1 (COIL B).
 - e. When applying this kit to a unit with 230 volt, connect the 700/BLU wire from LAC (120/240 VAC) to M1 (T2). When applying this kit to a unit with 460 or 575 volt, connect the 700/BLU wire from LAC (600 VAC) to M1 (T2).
6. Connect the temperature probe leads across probe S1 on LAC.

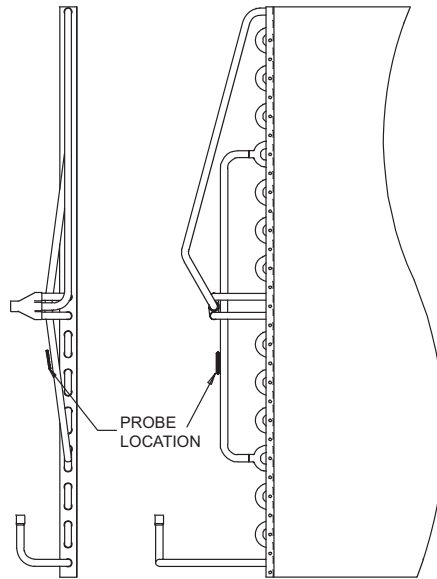
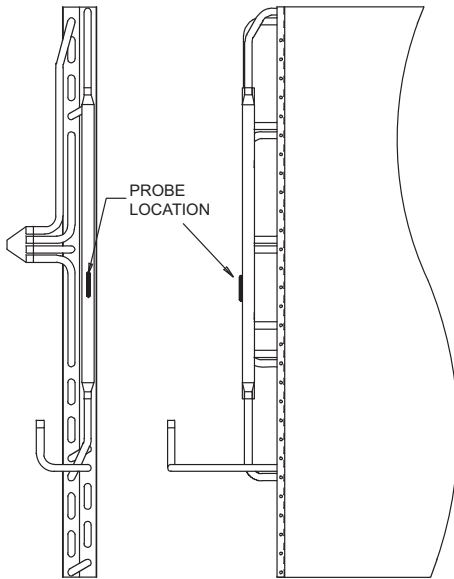

FIGURE 2 - PROBE LOCATION

7. In order to provide protection from high voltage, install an insulated quick connect terminal on the unused terminal (3 or 4) on the control.
8. Route the probe through the control box partition and into the condensing section. The slip joint pliers may be used to remove and re-install the strain relief.
9. Place the temperature probe on the intermediate header on the condenser coil. See Figure 2.

Peel the strip from the back of the self-vulcanizing tape provided and wrap the tape around the probe from the wire end forward to the end of the probe. Be sure to adequately stretch the tape to ensure weatherproofing. See Figure 3.

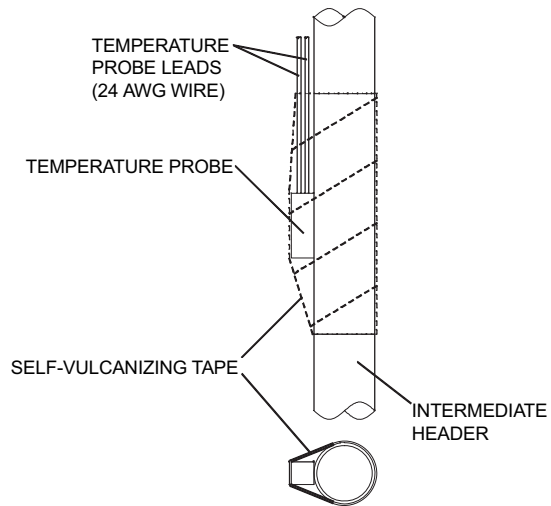

FIGURE 3 - TEMPERATURE PROBE

10. Adjust the "CUT-OUT" knob to the maximum. This prevents the motor RPM from dropping below the minimum for sleeve bearing. See Figure 4.

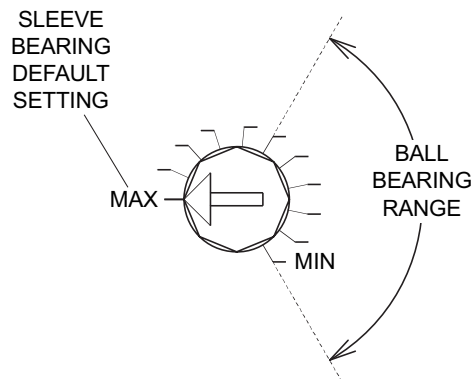

FIGURE 4 - CUT-OUT TEMPERATURE CALIBRATION

11. Adjust the "HARD START" knob to the maximum. This allows full voltage to be applied to the motor for a longer period during start-up. See Figure 5.

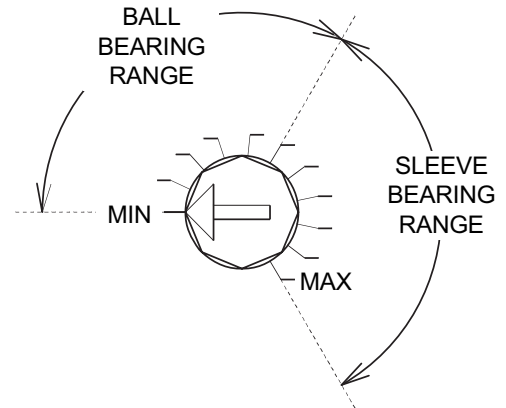

FIGURE 5 - HARD START CALIBRATION

12. Install the control access panel and condenser panel.
13. Restore the gas supply and electric power to the unit and verify proper operation.

