

JOB NAME _____ **LOCATION** _____
PURCHASER _____ **ORDER NO.** _____
ENGINEER _____
SUBMITTED TO _____ **FOR:** Reference Approval Construction
SUBMITTED BY _____ **DATE** _____

UNIT DESIGNATION: Schedule No. _____ **MODEL NO.** _____

PRODUCT DATA

STANDARD FEATURES

COOLING PERFORMANCE

TOTAL CAPACITY MBH
 SENSIBLE CAPACITY MBH
 OUTDOOR DESIGN °F DB/WB
 TOTAL SUPPLY AIR CFM
 TEMPERATURE OF AIR ENTERING
 EVAPORATOR COIL °F DB/WB
 POWER INPUT REQUIREMENT
 (LESS BLOWER MOTOR) KW.

HEATING PERFORMANCE

RESISTANCE HEAT KW
 CAPACITY MBH
 VOLTS

SUPPLY AIR BLOWER PERFORMANCE

TOTAL SUPPLY AIR CFM
 TOTAL RESISTANCE EXTERNAL
 TO UNIT IWG
 BLOWER SPEED (Circle) HI MED LOW
 MOTOR RATING HP
 POWER INPUT REQ. WATT.

ELECTRICAL DATA

POWER SUPPLY / /
 MINIMUM CIRCUIT AMPS AMPS
 MAXIMUM OVERCURRENT DEVICE
 FUSES CIRCUIT BREAKER AMPS.

UNIT WEIGHT (operating)

TOTAL UNIT WEIGHT LBS..

CLEARANCES

Front 12"
 Back 0"
 Left Side (Filter Access) 24"
 Right Side 24"
 Below Unit¹ 0"
 Above Unit² 36"

¹ Units may be installed on combustible floors made from wood or class A, B or C roof covering material.

² Units must be installed outdoors. Overhanging structures or shrubs should not obstruct condenser air discharge outlet.

NOTES;

- A 1" clearance must be provided between any combustible material and the supply air ductwork.
- Unit may be installed on combustible floors made from wood or class A, B or C roof covering material.
- Units must be installed outdoors. Overhanging structures or shrubs should not obstruct condenser air discharge outlet.

- Compact single size cabinet and footprint.
- Bottom and or side electrical utility connections.
- Top discharge condenser air design with flush mounted grille guard .
- Full perimeter, removable base rails with built in rigging and shipping provisions.
- Heavy gauge galvanized steel cabinet with paint finish which has industry leading 750 hour salt spray rating per ASTM-B117 federal test standards.
- Easily field convertible from side to bottom discharge. No other accessory needed.
- Attractive cabinet design with single piece "Water-Shed" top cover and drip edge to deter water collection and increase life.
- Factory installed, attractive protection condenser coil grille.
- High efficient rifled tube with enhanced fin condenser and evaporator coils.
- Foil face insulation which does not emit fibers into airstream.
- Permanently lubricated condenser and evaporator motors.
- Multi speed (3) direct drive high static motor and slide out blower assembly.
- Non corrosive condensate pan internally sloped to meet strict requirements of ASHRAE 62-89 Indoor Air Quality standard.
- Internal compressor protection (temperature and pressure).
- Standard cooling operation down to 45° F (Low ambient kit to 0° F available).
- Refrigerant system strainer.
- Ridged mounted, protected refrigerant access ports externally accessible.
- Both numbered and colored wires.
- All three phase models have built in filter rack with cleanable filters and 75 VA transformer with re-settable circuit breaker.
- 5 year compressor warranty.
- 1 year limited warranty on all other parts.
- 5 year electric heat element warranty.

**SINGLE PACKAGE COOLING UNITS
 (10 SEER)**

1½ THRU 5 TON, MODELS D__PB018 THRU 060

FORM 036-22434-001-A-0203

Supersedes: Nothing



DIMENSIONS - INCHES

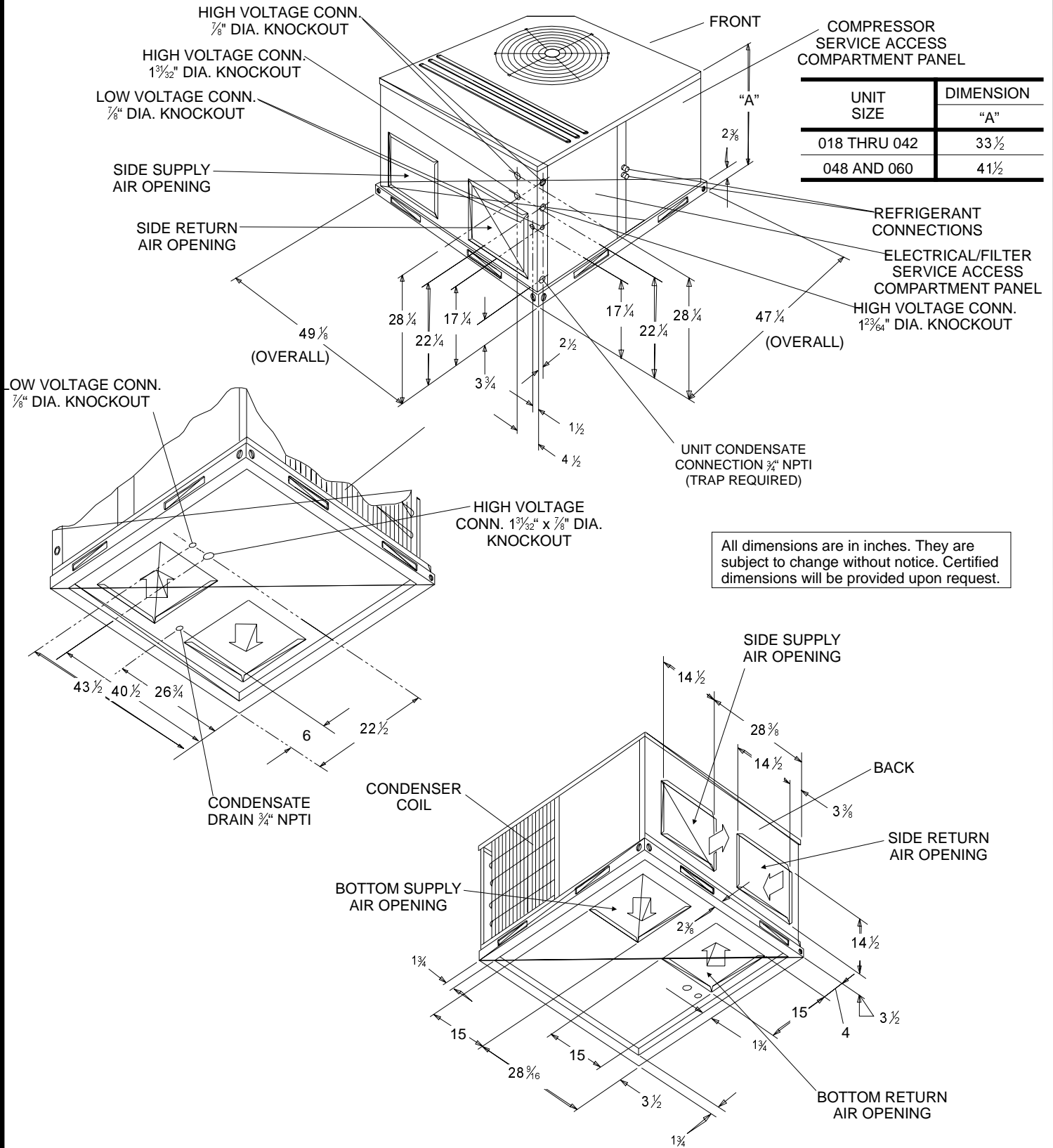

UNIT SIZE	DIMENSION "A"
018 THRU 042	$33\frac{1}{2}$
048 AND 060	$41\frac{1}{2}$

All dimensions are in inches. They are subject to change without notice. Certified dimensions will be provided upon request.

Copyright © 2003 by Unitary Products Group - ALL RIGHTS RESERVED

NOTES: _____

