

ACCESSORY KIT INSTALLATION MANUAL

IGNITION CONTROL P/N S1-33102956000 FOR MODELS: ALL SINGLE-STAGE 115VAC MODELS WITH HSI

GENERAL INFORMATION

This part is a direct replacement for part numbers S1-03109167000, S1-03101933000, S1-03101267000, S1-03101267001, S1-03100662000, S1-03101250000, S1-03101266000, S1-03101284000, S1-03101973000 and S1-03101972000, 265901 & 265902.

Figure 1 shows the basic board layout and Figure 2 shows the general component and safety circuit connections (Refer to the electrical wire diagram for the furnace being serviced for circuit connections specific to that model).

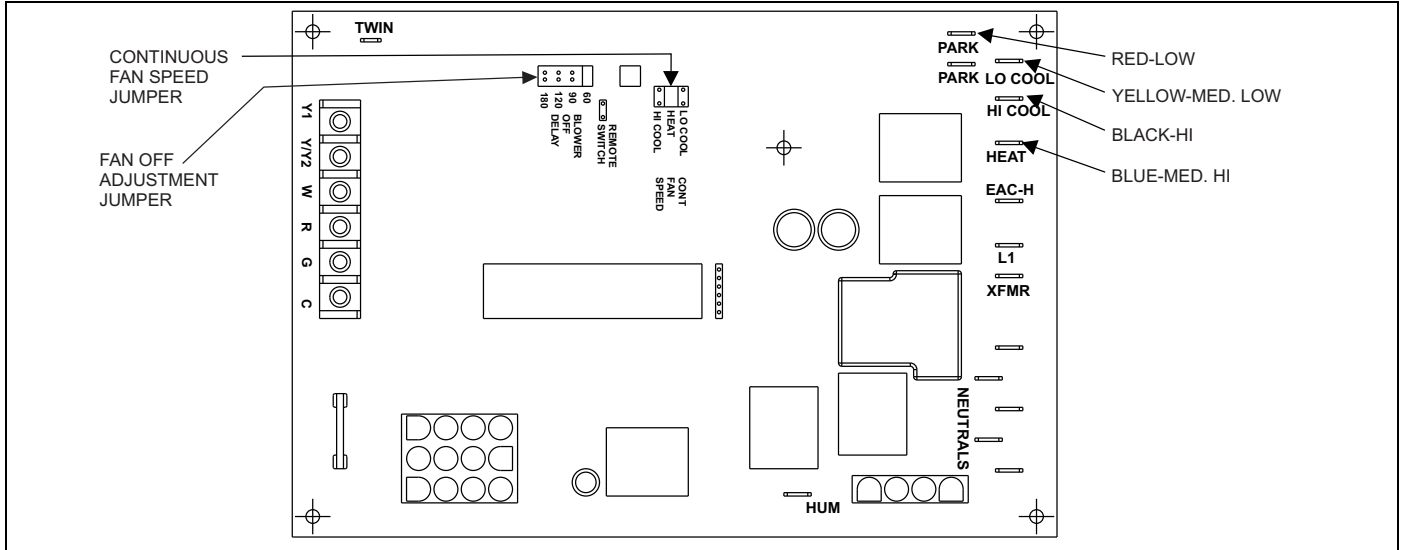

FIGURE 1: Furnace Control Board

INSTALLATION

The required number of steps to remove the failed ignition control and install the new ignition control will vary depending on the furnace model. However the wire connections will remain the same.

Some models (certain upflow 90% models) will require that the sheet metal control box be replaced. The existing door switch and transformer will be re-used.

Some models (BGU Series) will require that new holes be drilled in the existing control box and that the transformer be relocated.

Some models will need new mounting holes to be drilled in the existing panel. Use the drill template on the last page of these instructions as a guide.

WARNING

Disconnect electrical power to the furnace before installing this control. Failure to cut power could result in an electrical shock or equipment damage.

CAUTION

Label all wires prior to disconnection when servicing controls. Wiring errors can cause improper and dangerous furnace operation. Verify proper operation after servicing.

NOTE: All wiring must be in accordance with both the National Electric Code, latest edition, and all local electrical codes.

REMOVAL OF FAILED IGNITION CONTROL

1. Turn off electrical power.
2. Remove furnace vest and blower access panels.
3. Remove electrical box cover, if required.
4. Label all wires prior to disconnection.
5. Disconnect all wires to failed ignition control.
6. Remove screws or pegs fastening ignition control to electrical panel.
7. Fasten hole template, included with this installation instruction, to electrical panel and drill new mounting holes. (If required).

PARTS LIST

1. Ignition control P/N 33109167000
2. Replacement Control Box
3. Installation Instruction Sheet

INSTALLATION OF IGNITION CONTROL

1. Orient the control as close as possible to the orientation of the board being replaced.
2. Align the plastic mounting feet with the mounting holes in the electric panel and press on each corner of the control board to seat the mounting feet.

⚠ CAUTION

Apply only enough pressure to seat the mounting foot or the ignition control may be damaged.

3. Figure 2 shows a typical system wiring diagram, which may vary slightly depending on the furnace model. Use the wiring diagram label on the furnace as your primary guide.
4. Check to see that all wire connections were made properly before applying power.
5. Apply power and test furnace operation.

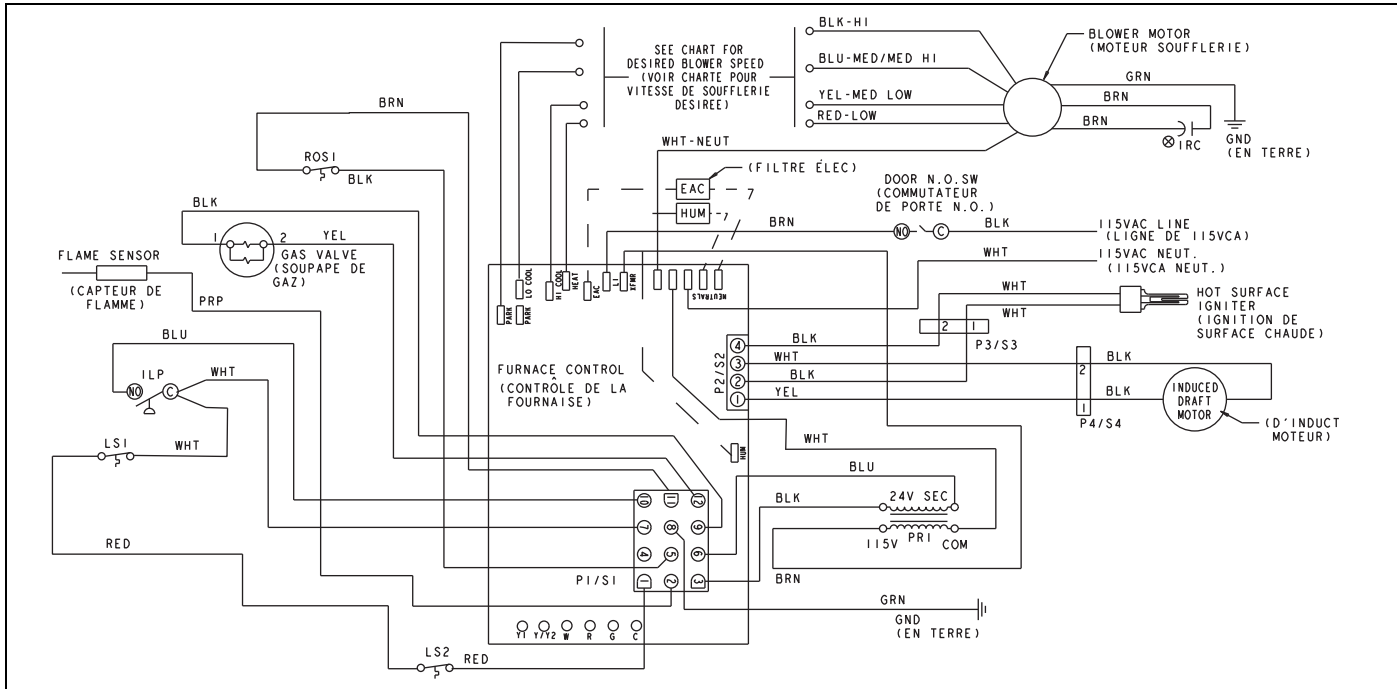

FIGURE 2: Board Layout - Typical System Wiring

FURNACE CONTROL DIAGNOSTICS

The furnace has built-in, self-diagnostic capability. If a system problem occurs, a blinking LED can flash red, green or amber to indicate various conditions.

The control continuously monitors its own operation and the operation of the system. If a failure occurs, the LED will indicate the failure code. If the failure is internal to the control, the light will stay on continuously. In this case, the entire control should be replaced, as the control is not field repairable.

Flash sequence codes 1 through 11 are as follows: LED will turn "on" for 1/4 second and "off" for 1/4 second. This pattern will be repeated the number of times equal to the code. For example, six "on" flashes equals a number 6 fault code. All flash code sequences are broken by a 2 second "off" period.

SLOW GREEN FLASH: Normal operation.

SLOW AMBER FLASH: Normal operation with call for heat.

RAPID RED FLASH: Twinning error, incorrect 24V phasing. Check twinning wiring.

RAPID AMBER FLASH: Flame sense current is below 1.5 microamps. Check and clean flame sensor. Check for proper

gas flow. Verify that current is greater than 1.5 microamps at flame current test pad.

4 AMBER FLASHES: The control is receiving a "Y" signal from the thermostat without a "G" signal, indicating improper thermostat wiring.

1 RED FLASH: This indicates that flame was sensed when there was not a call for heat. The control will turn on both the inducer motor and supply air blower. A gas valve that leaks or is slow closing would typically cause this fault.

2 RED FLASHES: This indicates that the normally open pressure switch contacts are stuck in the closed position. The control confirms these contacts are open at the beginning of each heat cycle. This would indicate a faulty pressure switch or mis-wiring.

3 RED FLASHES: This indicates the normally open pressure switch contact did not close after the inducer was energized. This could be caused by a number of problems: faulty inducer, blocked vent pipe, broken pressure switch hose or faulty pressure switch.

4 RED FLASHES: This indicates that a primary or auxiliary limit switch has opened its normally closed contacts. The control will operate the supply air blower and inducer. This condition may be caused by: dirty filter, improperly sized duct system, incorrect blower speed setting, incorrect firing rate or faulty blower motor. Also, this fault code could be caused by a blown fuse located on the control board.

5 RED FLASHES: This fault is indicated if the normally closed contacts in the rollout switch opens. The rollout control is manually reset. If it has opened, check for proper combustion air, proper inducer operation, and primary heat exchanger failure or burner problem. Be sure to reset the switch and cycle power (24 VAC) to the control after correcting the failure condition. Also, this fault code could be caused by a blown fuse located on the control board.

6 RED FLASHES: This indicates that after the unit was operating, the pressure switch opened 4 times during the call for heat. If the main blower is in a "Delay on" mode, it will complete it, and any subsequent delay off period. The furnace will lock out for one hour and then restart.

7 RED FLASHES: This fault code indicates that the flame could not be established. This no-light condition occurred 3 times (2 retries) during the call for heat before locking out. Low gas pressure, faulty gas valve, dirty or faulty flame sensor, faulty hot surface ignitor or burner problem may cause this. The furnace will lock out for one hour and then restart.

8 RED FLASHES: This fault is indicated if the flame is lost 5 times (4 recycles) during the heating cycle. This could be caused by low gas pressure, dirty or faulty flame sensor or faulty gas valve. The furnace will lock out for one hour and then restart.

9 RED FLASHES: Indicates reversed line voltage polarity or grounding problem. Both heating and cooling operations will be affected. Check polarity at furnace and branch. Check furnace grounding. Check that flame probe is not shorted to chassis.

10 RED FLASHES: Gas flow with no call for heat. Check gas valve and gas valve wiring.

11 RED FLASHES: This indicates that a primary or auxiliary limit switch has opened its normally-closed contacts and has remained open for more than five minutes. This condition is usually caused by a failed blower motor or blower wheel. Cycle power (24 VAC) to the control to reset the hard lockout condition after correcting the failure condition.

12 RED FLASHES: This code indicates an open igniter circuit, which could be a disconnected or loose wire or a cracked or broken igniter.

STEADY ON RED: Control failure. Replace control board.

60-MINUTE AUTOMATIC RESET FROM LOCKOUT: This control includes a "watchdog" type circuit that will reset from a lockout condition after 60 minutes. Operational faults 6,7,8 will be reset. This provides protection to an unoccupied structure if a temporary condition exists causing a furnace malfunction. An example would be a low incoming gas supply pressure preventing unit operation. When the gas pressure is restored, at some point the "watchdog" would restart the unit and provide heat for the house.

If a flame is detected the control flashes the LED for 1/8 of a second and then enters a flame stabilization period.

<p>IGNITION CONTROL</p> <p>Normal flame sense current is approximately 3.7 microamps DC (μa)</p> <p>Low flame signal warning starts at 1.5 microamps. Low flame signal control lockout point is 0.1 microamps DC (μa)</p>
--

DIAGNOSTIC FAULT CODE STORAGE AND RETRIEVAL

The control in this furnace is equipped with memory that will store up to five error codes to allow a service technician to diagnose problems more easily. This memory will be retained even if power to the furnace is lost. **This feature should only be used by a qualified service technician.**

The control stores up to five separate error codes. If more than five error codes have occurred since the last reset, only the five most recent will be retained. The furnace control board has a button, labeled "LAST ERROR" that is used to retrieve error codes. This function will only work if there are no active thermostat signals. So any call for heating, cooling or continuous fan must be terminated before attempting to retrieve error codes.

To retrieve the error codes, push the LAST ERROR button. The LED on the control will then flash the error codes that are in memory, starting with the most recent. There will be a two-second pause between each flash code. After the error codes have all been displayed, the LED will resume the normal slow green flash after a five second pause. To repeat the series of error codes, push the button again.

If there are no error codes in memory, the LED will flash two green flashes. To clear the memory, push the LAST ERROR button and hold it for more than five seconds. The LED will flash three green flashes when the memory has been cleared, then will resume the normal slow green flash after a five-second pause.

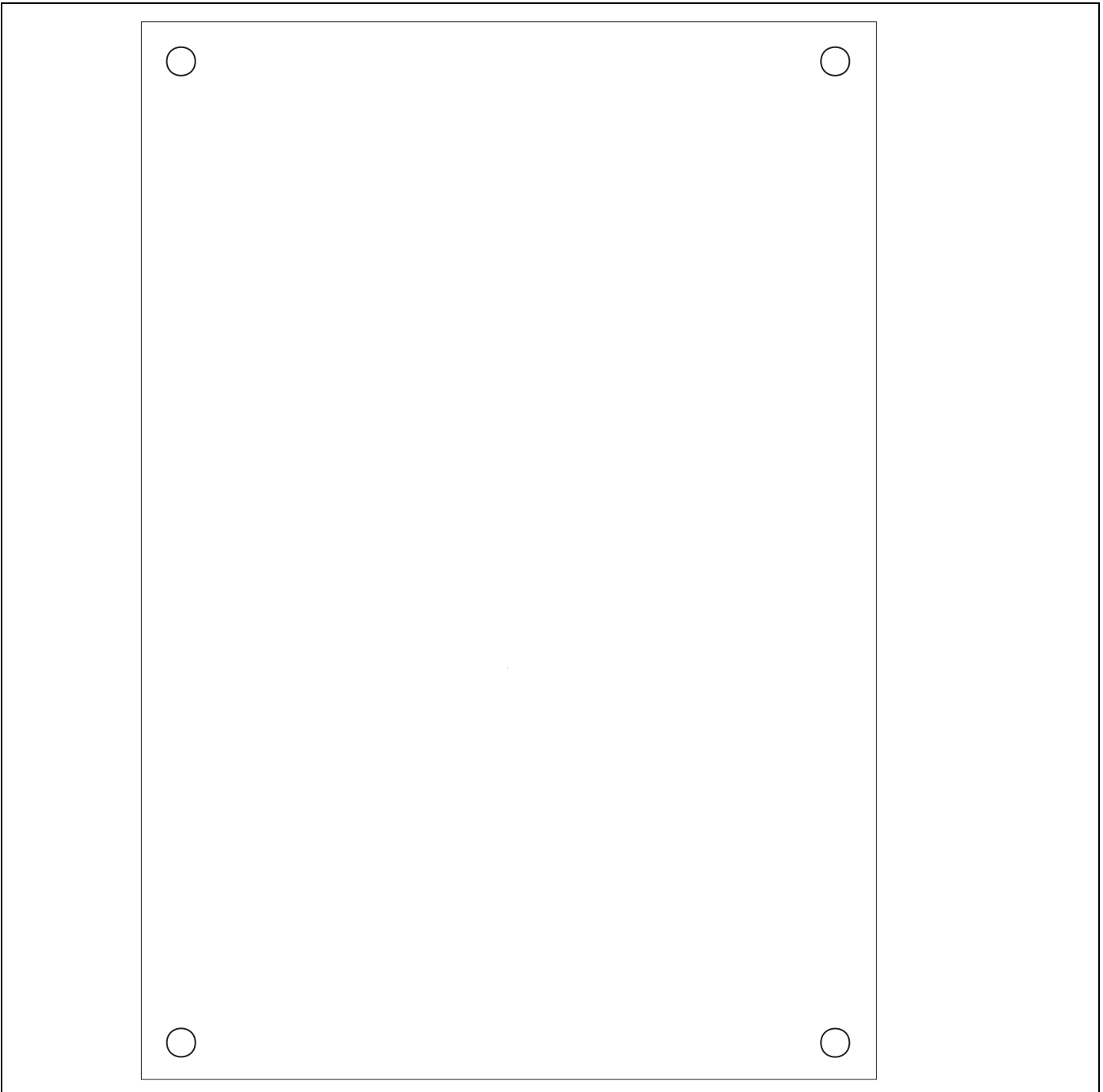

FIGURE 3: Hole Template