

INSTALLATION MANUAL

CONTENTS

GENERAL	4
SAFETY CONSIDERATIONS	4
AGENCY APPROVALS	4
INSPECTION	4
INSTALLATION	6
MAINTENANCE	18

See the following page for a complete Table of Contents.

NOTES, CAUTIONS AND WARNINGS

Installer should pay particular attention to the words: *NOTE*, *CAUTION*, and *WARNING*. *Notes* are intended to clarify or make the installation easier. *Cautions* are given to prevent equipment damage. *Warnings* are given to alert installer that personal injury and/or equipment damage may result if installation procedure is not handled properly.

CAUTION: READ ALL SAFETY GUIDES BEFORE YOU BEGIN TO INSTALL YOUR UNIT.

SAVE THIS MANUAL

SPLIT-SYSTEM HEAT PUMPS INDOOR UNITS

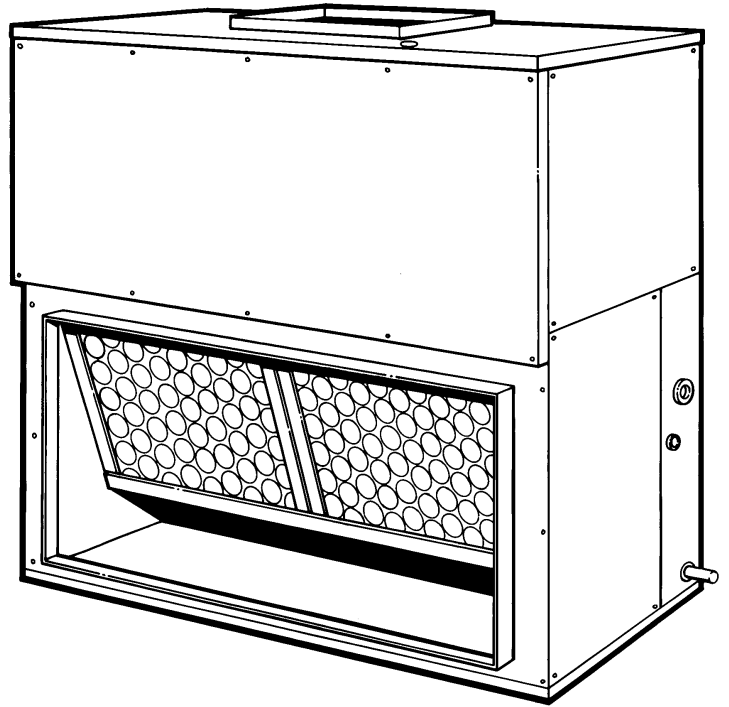

MODEL: FF-07



TABLE OF CONTENTS

NOMENCLATURE	3
GENERAL	4
SAFETY CONSIDERATIONS	4
REFERENCE	4
RENEWAL PARTS	4
AGENCY APPROVALS	4
INSPECTION	4
INSTALLATION	6
LIMITATIONS.....	6
LOCATION.....	6
RIGGING AND HANDLING	6
CLEARANCES.....	7
VERTICAL/HORIZONTAL INSTALLATION.....	7
DUCT CONNECTIONS	8
DRAIN CONNECTION.....	9
REFRIGERANT MAINS.....	9
INSTALLING REFRIGERANT MAINS	10
EXPANSION VALVE BULB	10
POWER AND CONTROL WIRING	10
SUPPLY AIR BLOWER ADJUSTMENT	12
MAINTENANCE	18
INDOOR COIL	18
FILTERS	18
DRAIN PAN	18
LUBRICATION.....	18
BELTS	18

LIST OF FIGURES

<u>Fig. #</u>		<u>Pg. #</u>
1	UNIT SUSPENSION MOUNTING	7
2	VERTICAL AND HORIZONTAL APPLICATION	8
3	SUPPLY AIR DUCT CONNECTIONS.....	8
4	ELECTRIC HEATER ACCESSORY	8
5	SUPPLY AIR PLENUM ACCESSORY	9
6	BASE ACCESSORY	9
7	RETURN AIR GRILLE ACCESSORY	9
8	RECOMMENDED DRAIN PIPING.....	9
9	FIELD WIRING	12
10	TYPICAL MOTOR MOUNTING ASSEMBLY.....	13
11	HOLE LOCATIONS FOR PRESSURE DROP READINGS	14
12	PRESSURE DROP ACROSS A DRY INDOOR COIL VS. SUPPLY AIR CFM.....	14
13	FA090 AIRFLOW CHART	15
14	UNIT DIMENSIONS & CLEARANCES	17

LIST OF TABLES

<u>Tbl. #</u>		<u>Pg. #</u>
1	PHYSICAL DATA.....	5
2	APPLICATION DATA.....	5
3	ELECTRICAL DATA	11
4	ELECTRICAL DATA - UNITS W/ELEC. HEAT ACC. 11	11
5	SUPPLY AIR BLOWER MOTOR PULLEY ADJUSTMENT.....	13
6	SUPPLY AIR BLOWER PERFORMANCE	15
7	ACCESSORY STATIC RESISTANCE (IWG)	16
8	BLOWER MOTOR AND DRIVE DATA	16

NOMENCLATURE**INDOOR SPLIT UPG PRODUCT NOMENCLATURE****F F -07 C 00 S A AA 1 A**

Model #	Model Number Description	Options
F	Product Category	L = Air Handling Unit - Cooling F = Air Handling Unit - Heat Pump
F	Product Identifier	F = R-22 Standard Efficiency 2-Pipe L = R-22 Standard Efficiency 4-Pipe
-07	Nominal Cooling Capacity MBH	-07 = 7-1/2 Ton -10 = 10 Ton -15 = 15 Ton -20 = 20 Ton
C	Heat Type	C = Cooling Only
00	Nominal Heating Capacity	00 = No Heat Installed
A	Airflow Options	A = None
S	Voltage	S = 208/230-460-3-60
A	Factory Options	A = None
AA	Special Options	AA = None
1	Generation	1 = First Generation 2 = Second Generation
A	Product Style	A = Style A B = Style B

***NOT AVAILABLE IN HEAT PUMP**

GENERAL

These completely assembled indoor units include a well-insulated cabinet, a copper tube/aluminum fin coil, throwaway filters, a centrifugal blower, a blower motor, an adjustable V-belt drive, a blower motor contactor and a small holding charge of Refrigerant-22. They also include a filter-drier, an expansion valve and a distributor that are only used during the cooling cycle plus check valves to provide the proper flow of refrigerant through the coil during both the cooling and heating cycles.

Supplemental resistance heaters, a supply air plenum, a return air grille and a base are available as accessories for field installation.

The units are shipped in the vertical position ready for field installation. For horizontal installation, reverse the solid bottom panel and the return air duct flange on the front of the unit.

SAFETY CONSIDERATIONS

Installer should pay particular attention to the words: NOTE, CAUTION and WARNING. Notes are intended to clarify or make the installation easier. Cautions are given to prevent equipment damage. Warnings are given to alert the installer that personal injury and/or equipment damage may result if the installation procedure is not handled properly.

WARNING

Improper installation may create a condition where the operation of the product could cause personal injury or property damage.

Improper installation, adjustment, alteration, service or maintenance can cause injury or property damage. Refer to this manual for assistance or additional information, consult a qualified installer or service agency.

CAUTION

This product must be installed in strict compliance with the enclosed installation instructions and any applicable local, state, and national codes including, but not limited to building, electrical, and mechanical codes.

REFERENCE

Additional information on the design, installation, operation and service of this equipment is available in the following reference forms.

Form 55.70-N1 - General Installation
Form 55.70-N2 - Pre-start & Post-start Check List
Form 55.70-N3 - General Service Information
Form 55.05-NM - Evacuation and Charging

RENEWAL PARTS

Refer to Parts Manual for complete listing of replacement parts on this equipment.

All forms referenced in this instruction may be ordered from:

Standard Register
2101 W. Tecumseh Rd
Norman, Oklahoma 73069
Toll Free Tel: 877-318-9765
Toll Free Fax: 877-319-7920

This instruction covers the installation of the indoor unit. For information on the installation and operation of the matching outdoor unit, refer to PN 035-18547-001.

AGENCY APPROVALS

Design certified by UL as follows:

1. For use as a cooling/heat pump coil, air handler only.
2. For indoor installation only.

INSPECTION

As soon as a unit is received, it should be inspected for possible damage during transit. If damage is evident, the extent of the damage should be noted on the carrier's freight bill. A separate request for inspection by the carrier's agent should be made in writing. See Form 50.15-NM for more information.

TABLE 1: PHYSICAL DATA

		Description	Unit Model FF-07	
Evaporator Coils	Rows Deep x Rows Wide		3 x 32	
	Finned Length - inches		46	
	Face Area - square feet		10.1	
	Tube OD - inches		3/8	
	Fins per inch		13	
Centrifugal Blower (Forward Curve)	Diameter x Width - inches		15 x 15	
Motors ¹	Nominal HP Rating		1-1/2	
Filters (Throwaway)	Quantity Per Unit	16" x 25" x 1	4	
	Face Area - square feet		11.1	
Distributor	One Per Unit		5-3-10-12 ²	
Operating Weight, Lbs. ³	Holding Charge		9.5 oz.	
	Basic Unit		385	
	Accessories			
	Supply Air Plenum		102	
	Return Air Grille		15	
	Hot Water Coil		82	
	Steam Coil		85	
	Base		60	
	Electric Heat:	10 KW		63
		16 KW		66
26 KW		71		
36 KW		74		
Hot Water Coil	Tubes OD, inches		1/2 (Copper)	
	Rows Deep		2	
	Fins Per Inch		12 (Aluminum)	
	Face Area, square feet		6.8	
	Connections (Supply & Return)		1" NPTE	
Steam Coil	Outer Tube OD, inches		1 (Brass)	
	Rows Deep		1	
	Fins Per Inch		8 (Aluminum)	
	Face Area - square feet		6.6	
	Connection	Inlet	1-1/2" NPTE	
Outlet		1-1/2" NPTE		
Electric Heat	Heater Elements	% Nickel	59.2	
		% Chromium	16.0	
		watts/sq. in.	59.0	
	Face Area, square feet		3.0	

1. Refer to Blower Motor and Drive Data for additional blower motor and drive information. All of these 1750 RPM motors have a solid base, a 56 frame, a 1.15 service factor, inherent protection & permanently lubricated ball bearings.
2. The first digit refers to inlet diameter (1/8"), second digit refers to tube diameter (1/16") and the third digit refers to number of tubes and the fourth digit refers to number of distributors.
3. Refer to Figure 1 and Table 3 for distributed weight of Evaporator Blower Unit.

TABLE 2: APPLICATION DATA

Model	Power Supply	Voltage Variation ¹		Supply Air CFM		Entering Air Temperatures, °F			
		Min.	Max.	Min.	Max.	Cooling - wb		Heating - db	
						Min.	Max.	Min.	Max.
FF-07	208/230-3-60	187	252	2400	3600	57	72	50 ²	80
	460-3-60	414	506						

1. Utilization Range "A" in accordance with ARI Standard 110.
2. The system may operate below 50° F for a short period of time when warming up the conditioned space after a long shutdown.

INSTALLATION

LIMITATIONS

These units must be installed in accordance with all national and local safety codes. If no local codes apply, installation must conform with the appropriate national codes. Units are designed to meet National Safety Code Standards. If components are to be added to a unit to meet local codes, they are to be installed at the dealer's and/or the customer's expense. See Table 2 for application data.

LOCATION

These Evaporator Blowers are not designed for outdoor installation. They must be located within the building structure, either inside or outside the conditioned space.

These Evaporator Blower sections allow for vertical or horizontal installation in any area offering proper electrical supply, duct and drain connections.

They may be installed either with ductwork or matching plenum and inlet grille.

The units should be located as close to the condensing units as practical and positioned to minimize bends in the refrigerant piping.

Units being installed vertically or horizontally can be set directly on a floor or platform, or metal or wooden beams can support them.

Units being installed horizontally can be suspended from above. Four 3/8" weld nuts are provided in the unit frame to accommodate hanger rods. Knockouts must be removed from the unit panels to expose these weld

nuts. Refer to Figure 1 for their location and the individual load on each hanger rod.

A field added secondary drain pan may be required in locations where possible condensate overflow could cause damage.

WARNING

Be careful when attaching the hanger rods. Use a washer with a back-up nut on each rod and tighten down against the cabinet so they will not be allowed to turn or slip.

RIGGING AND HANDLING

Be careful when moving the unit. Do not remove any packaging until the unit is near its final location.

The packaging consists of a bottom wooden skid that can be lifted with a fork truck from any direction, a cardboard container that covers the entire unit, and strapping that secures the cardboard container to the bottom skid.

These units can be rigged with slings under the bottom skid.

CAUTION

Spreader bars should be used to prevent the slings from crushing the unit panels and frame.

Before rigging any unit, determine its weight from Table 1. Before rigging a unit for horizontal installation, determine its center of gravity from Figure 1 and make sure that its weight will be distributed equally.

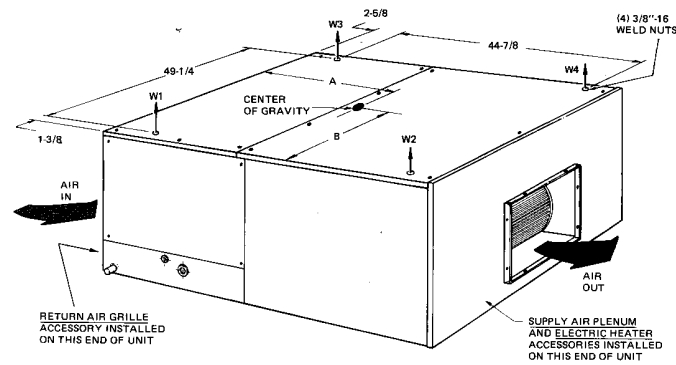

Model	Accessory	Based on a Standard Blower Motor						
		Center of Gravity Dimensions, In.		Weight Distribution, Lbs.				
		A	B	W1	W2	W3	W4	Total
FF-07	Basic Unit Only	24-1/8	23-1/4	112	102	89	82	385
	Unit with Electric Heat	29-1/4	23-3/8	100	150	81	122	453
	Unit with Plenum	33-3/8	23-1/2	85	184	68	150	487
	Unit with Electric Heat and Plenum	36-5/8	23-5/8	74	230	61	190	555

NOTE: Unit weights (with electric heat accessory) are based on an average heater weight of 68 lbs.

FIGURE 1 - UNIT SUSPENSION MOUNTING (Horizontal Application)

CLEARANCES

The clearances listed on the unit dimension drawing (Figure 14) are required for the proper service and operation of the unit.

VERTICAL/HORIZONTAL INSTALLATION

These evaporator blowers are shipped for vertical installation with vertical air discharge as shown in Figure 2(A) but may be converted for horizontal installation as shown in Figure 2(B) by interchanging the solid bottom panel and the return air duct flange.

NOTE: Certain blower positions are not recommended because the blower motor should not be mounted upside down.

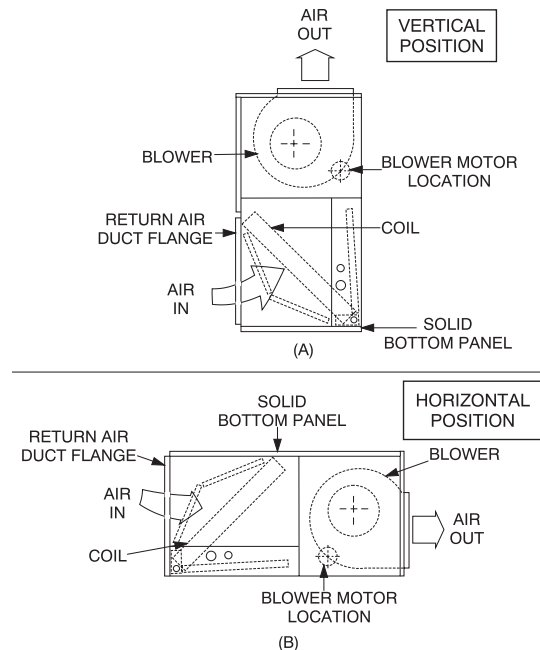

FIGURE 2 - VERTICAL AND HORIZONTAL APPLICATION

DUCT CONNECTIONS

All ducts should be designed and installed in accordance with all national and/or local codes.

Refer to Figure 3 for suggested method of connecting supply air ductwork.

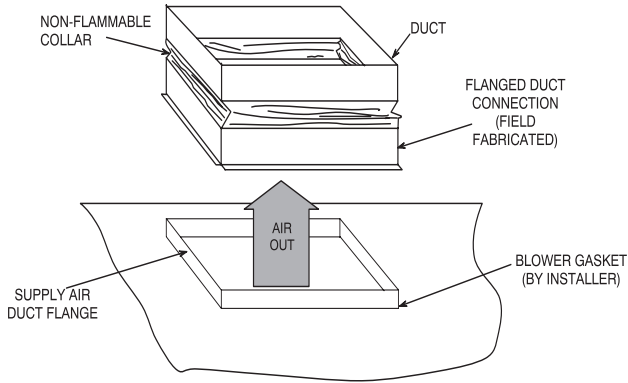

FIGURE 3 - SUPPLY AIR DUCT CONNECTIONS

Ducts should be sized no smaller than the duct flanges on the unit or the electric heater (if used). Refer to the unit dimensions (Figure 14) and the heater detail (Figure 4) for these sizes. Refer to Form 035-16602-001 for installation instructions on the electric heater.

Use flexible fiber glass or plastic cloth collars or other non-flammable material at the unit duct connections to minimize the transmission of noise and vibration.

Insulate all ductwork running through unconditioned areas to prevent moisture condensation and to provide more economical operation.

The return air duct flange is factory-mounted on the front of the unit, but it can be reversed with the solid bottom panel for horizontal applications.

A supply air plenum (Figure 5), a base (Figure 6) and a return air grille (Figure 7) are available as field-installed accessories, and one of the following respective instructions will be packed with each.

- PN 035-16650-001 - Supply Air Plenum
- PN 035-16621-001 - Return Air Grille
- PN 035-16632-001 - Base

The supply air plenum and the return air grille should be used in lieu of ductwork only when a free blow/free return application is practical.

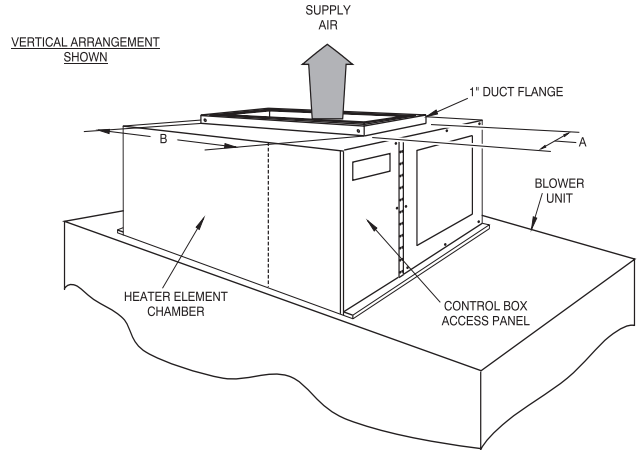
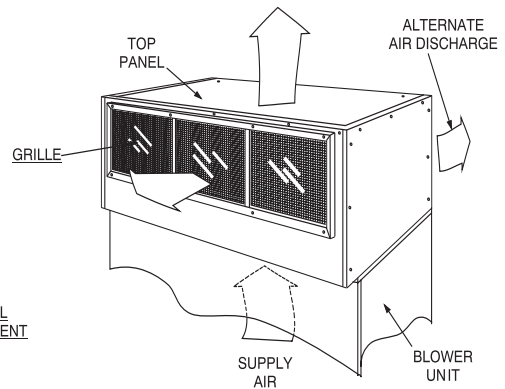

FIGURE 4 - ELECTRIC HEATER ACCESSORY (VERTICAL ARRANGEMENT SHOWN)



Plenum should be field mounted on the supply air end of blower units for either vertical or horizontal application. For rear discharge, rotate plenum 180 degrees. For horizontal discharge on a horizontal unit, the grille panel and the top panel will be arranged differently. Refer to Form 035-16650-001 for installation and assembly instructions.

FIGURE 5 - SUPPLY AIR PLENUM ACCESSORY (VERTICAL ARRANGEMENT SHOWN)

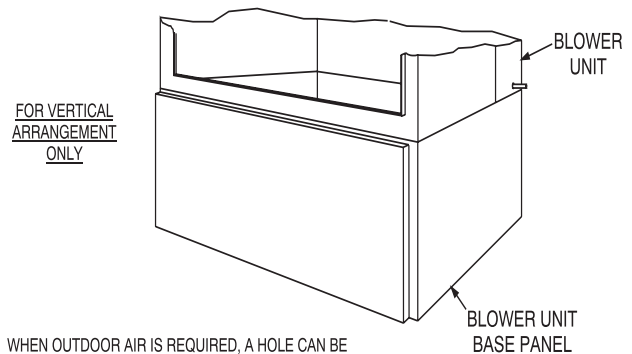
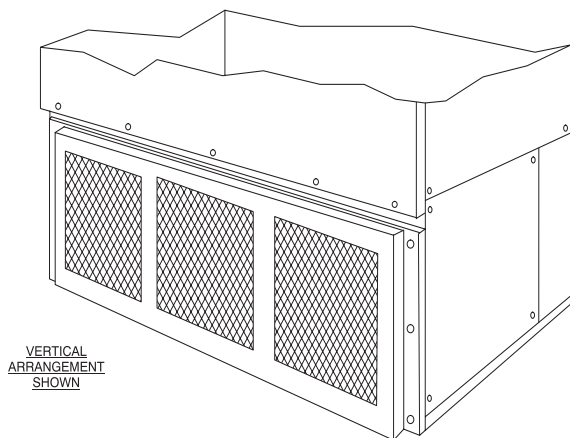

FIGURE 6 - BASE ACCESSORY (FOR VERTICAL ARRANGEMENT ONLY)



**FIGURE 7 - RETURN AIR GRILLE ACCESSORY
(VERTICAL ARRANGEMENT SHOWN)**

DRAIN CONNECTION

The drain line **MUST** be trapped because the coil is located on the negative side of the supply air blower, and it must be protected from freezing temperatures.

A 7/8" OD drain connection extends through right hand side of cabinet. Refer to Figure 8 for recommended drain piping.

The drain connection is located on the same side of the unit as the refrigerant connections. The line should be insulated where moisture drippage will be objectionable or cause damage to the area.

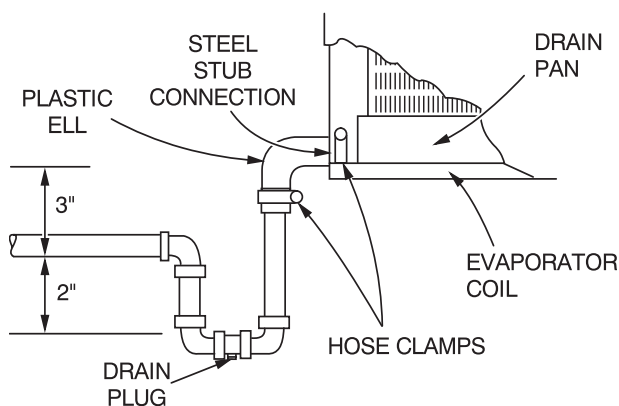

FIGURE 8 - RECOMMENDED DRAIN PIPING

The 3" dimension must be equal or exceed the negative static pressure developed by the supply air blower. If it does not, the condensate will not drain properly and may overflow the drain pan. The trap must be at least

2-1/2" deep to maintain a water seal under all operating conditions, especially during blower start-up.

NOTE: The unit may have to be raised off the floor to allow enough height for the trap.

REFRIGERANT MAINS

Many service problems can be avoided by taking adequate precautions to provide an internally clean and dry system and by using procedures and materials that conform with established standards.

Use hard drawn copper tubing where no appreciable amount of bending around pipes or other obstructions is necessary. Use long radius ells wherever possible with one exception - small radius ells for any traps in a vapor riser. If soft copper is used, care should be taken to avoid sharp bends which may cause a restriction.

Fiber glass insulation and a sealing material such as permagum should be packed around refrigerant lines where they penetrate a wall to reduce vibration and to retain some flexibility.

Support all refrigerant lines at minimum intervals with suitable hangers, brackets or clamps.

Braze all copper to copper joints with Sil-Fos 5 or equivalent brazing material. **DO NOT USE SOFT SOLDER.**

Never braze or solder the liquid and vapor lines together. The complete vapor line should be insulated with minimum 1/2" ARMAFLEX or equivalent.

If it is desirable to fasten these lines together for support purposes, they must be completely insulated, one from the other.

Refer to the appropriate condensing unit installation instructions for the matching outdoor unit for piping limitations, line sizes, and other design considerations.

INSTALLING REFRIGERANT MAINS

The units are evacuated and dehydrated at the factory and shipped with a holding charge of Refrigerant-22. The suction and liquid connections are sealed with copper discs. Refer to the appropriate condensing unit installation instructions for charging data.

Before starting installation of the mains be sure the unit has not developed a leak in transit by drilling a small

hole in the sealing discs. If pressure still exists, the circuit may be considered leak free. If pressure does not exist the coil should be leak tested.

NOTE: To minimize the possibility of system failure due to dirt and moisture, a filter-drier must be installed in the liquid line as close to the evaporator as possible. Filter-driers are not supplied with the evaporator blowers. They are supplied with the matching condensing sections.

If solenoid valves are required, they must be purchased and installed in the field. The temperature required to make or break a brazed joint is sufficiently high to cause oxidation of the copper unless an inert atmosphere is provided.

▲ CAUTION

Dry nitrogen should flow through the system at all times when heat is being applied and until the joint has cooled.

The liquid and suction connections must be piped outside the unit. Refer to the unit drawing for locations and the dimensions of these connections.

Before brazing the refrigerant lines to these connections, remove the short panel from the unit frame and

slide it (along with the grommets) onto the refrigerant lines. After the brazed joints have cooled, slide the panel back into place and secure it to the unit frame.

NOTE: These units can only be piped from one side of the unit.

EXPANSION VALVE BULB

The expansion valve bulb must be fastened in a 10 or 2 o'clock position to the suction line outside the cabinet after the piping connections have been made.

Use the clamps provided with the valve to secure the bulb in position. Bulb must be insulated with armaflex or mastic to assure proper operation.

POWER AND CONTROL WIRING

Install electrical wiring in accordance with the latest National Electrical Code (NFPA standard No. 70) and/or local regulations. The unit should be grounded in accordance with these codes.

Route the power wires into the unit through the 1-3/8" knockout in the rear panel, and connect them to the terminals on blower motor contactor 10M. Route the control wires into the unit through the 7/8" hole in the rear panel, and connect them to the terminals on block TB1. Refer to the unit drawing in Figure 14 for the locations of these knockouts.

CONTROL WIRE SIZING

Wire Size	Maximum Total Circuit Length (Feet)
#19 Solid	130
#18 Solid	170
#18 Stranded	180
#16 Stranded	270
#14 Stranded	455
#12 Stranded	730

To determine the total circuit length, add the following distances:

- 1 - Outdoor Unit to Indoor Unit _____
 2 - Indoor Unit to Thermostat _____
 3 - Thermostat to Indoor Unit _____
 4 - Indoor Unit to Outdoor Unit _____
 5 - Outdoor Unit to Elec. Heater _____
 Total Circuit Length _____

If the unit includes an electric heat accessory, route the power wires into heater control box in lieu of the unit.

Refer to Table 3 to size the disconnect switch, the power wiring, the fuses and the control wiring. Refer to Figure 9 for field wiring diagram.

NOTE: Motors are wired for a 460V power supply. Refer to the wiring diagram inside the motor terminal box when reconnecting motor leads for a 208 or 230 volt power supply.

If the supply air blower rotates in the wrong direction, reverse two of the motor leads at blower motor contactor 10M.

TABLE 3: ELECTRICAL DATA

Blower Motor HP	Power Supply	FLA	Max. Fuse Size, ¹ AMPS
FF-07			
1-1/2	208-3-60	5.2	15
	230-3-60	5.0	15
	460-3-60	2.6	15

¹. Dual element, time delay fuses.

TABLE 4: ELECTRICAL DATA - UNITS WITH ELECTRIC HEAT ACCESSORY

Model Basic Unit ¹	Nominal Heater KW ²	Power Supply Voltage ³	Full Load Amps		Total Ampacity (Amps)	Max Fuse Size ⁴ , Amps
			Heater	Blower Motor		
FF-07	10	208	20.8	5.2	32.6	35
		230	23.1	5.0	35.1	40
		460	11.5	2.6	17.7	20
	16	208	33.4	5.2	48.2	50
		230	36.9	5.0	52.4	60
		460	18.4	2.6	26.3	30
	26	208	54.2	5.2	74.3	80
		230	59.9	5.0	81.2	90
		460	30.0	2.6	40.7	45
	36	208	75.1	5.2	100.3	110
		230	83.0	5.0	110	125
		460	41.5	2.6	55.1	60

- Units with an electric heat accessory will always be wired for a single power supply.
- Refer to HEATING CAPACITY table for the actual KW and MBH ratings of each heater at the different voltages.
- All voltages for 3-phase, 60 hertz operation.
- Inverse time circuit breakers may be used in lieu of dual element, time delay fuses.

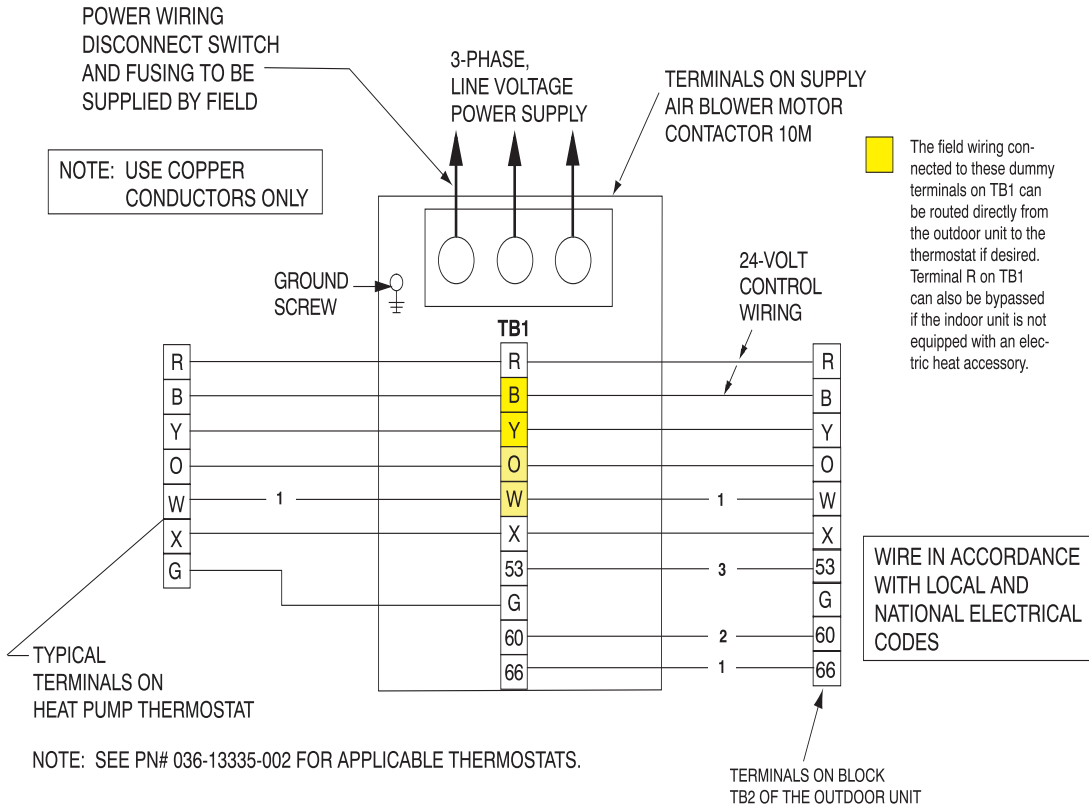

- ¹ Only required when an electric heat accessory is used.
- ² Only required when a 16 or 26 KW electric heat accessory is used.
- ³ Only required when a 36KW electric heat accessory is used.

NOTE: Refer to electric heat instruction 035-16602-001 for additional power and control wire requirements if the indoor unit is equipped with an electric heat accessory.

FIGURE 9 - FIELD WIRING

SUPPLY AIR BLOWER ADJUSTMENT

The RPM of the supply air blower will depend on the required CFM, the unit accessories and the static resistances of both the supply and the return air duct systems. With this information, the RPM for the supply air blower can be determined from the blower performance in Table 6.

Knowing the required blower RPM and the blower motor HP, the setting (turns open) for the supply air motor pulley can be determined from Table 5.

TABLE 5: SUPPLY AIR BLOWER MOTOR PULLEY ADJUSTMENT

TURNS OPEN*	DRIVE RANGE
	FF-07 690 - 920
5	690
4	730
3	770
2	815
1	850
0	920

* Pulleys can be adjusted in half-turn increments.

Each motor pulley has:

1. A threaded barrel with two flats (or notched recesses) 180 degrees apart.
2. A movable flange with one set screw.

After the movable flange has been rotated to the proper number of “turns open”, the set screw should be tightened against the flat on the barrel to lock the movable flange in place. If the pulley includes a locking collar, the locking collar must be loosened to adjust the setting of the movable flange.

Note the following:

1. The supply air CFM must be within the limitations shown in Table 2.
2. All pulleys can be adjusted in half-turn increments.
3. The tension on the belt should be adjusted for a deflection of $3/16$ of an inch per foot of belt span with an applied force of 2 to 3 pounds. This adjustment is made by moving the blower motor mounting plate. Refer to Figure 10. Turning the adjustment bolt (B) moves the motor mounting

plate up or down. Note - Never loosen the two nuts (C). Two hex nuts (A) have to be loosened to move the mounting plate and retightened after the mounting plate has been moved to the proper position.

4. All pulleys are factory aligned.
5. All supply air motor pulleys are factory set at 3 “turns open”.

After the supply air blower motor is operating, adjust the resistances in both the supply and the return duct systems to balance the air distribution throughout the conditioned space. The job specifications may require that this balancing be done by someone other than the equipment installer.

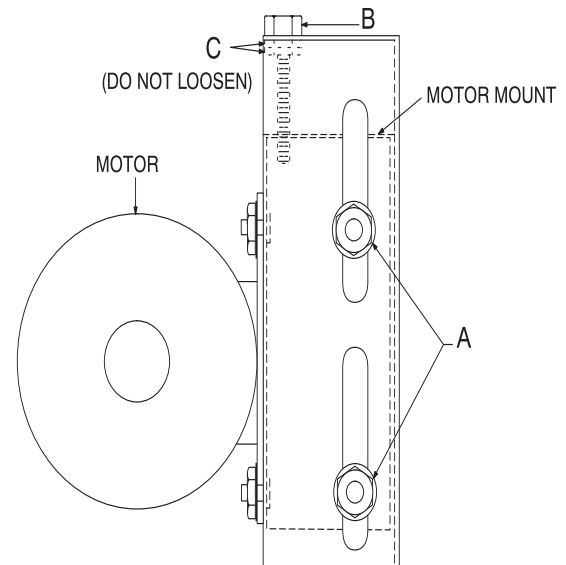

FIGURE 10 - TYPICAL MOTOR MOUNTING ASSEMBLY

To check the supply air CFM after the initial balancing has been completed:

1. Drill two $5/16$ inch holes in the side panel as shown in Figure 11.
2. Insert at least 6" of $1/4$ inch tubing into each of these holes for sufficient penetration into the air flow on both sides of the indoor coil.

NOTE: The tubes must be inserted and held in a position perpendicular to the air flow so that velocity pressure will not affect the static pressure readings.

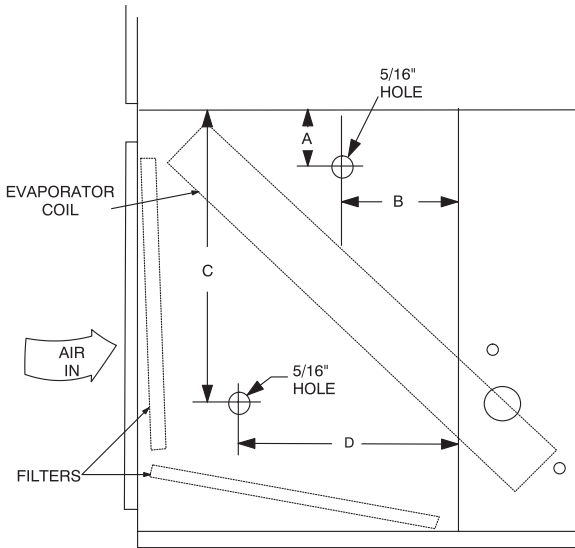

FIGURE 11 - HOLE LOCATIONS FOR PRESSURE DROP READINGS

- Using an inclined manometer, determine the pressure drop across a dry indoor coil. Since moisture on the coil may vary greatly, measuring the pressure drop across a wet coil under field conditions would be inaccurate. To assure a dry coil, the heat pump system should be de-activated while the test is being run.

- Knowing the pressure drop across a dry coil, the actual CFM through a unit can be determined from the curve in Figure 12.

If the CFM is above or below the specified value, the supply air motor pulley may have to be re-adjusted. After one hour of operation, check the belt and pulleys for tightness and alignment.

WARNING

Failure to properly adjust the total system CFM can result in extensive blower damage or system damage.

After readings have been obtained, remove the tubes and seal up the drilled holes in the side panel. Dot plugs (5/16" - P/N 029-13880-000) are available through normal York parts ordering procedures.

NOTE: Shut down the heat pump system before taking any test measurements to assure a dry indoor coil.

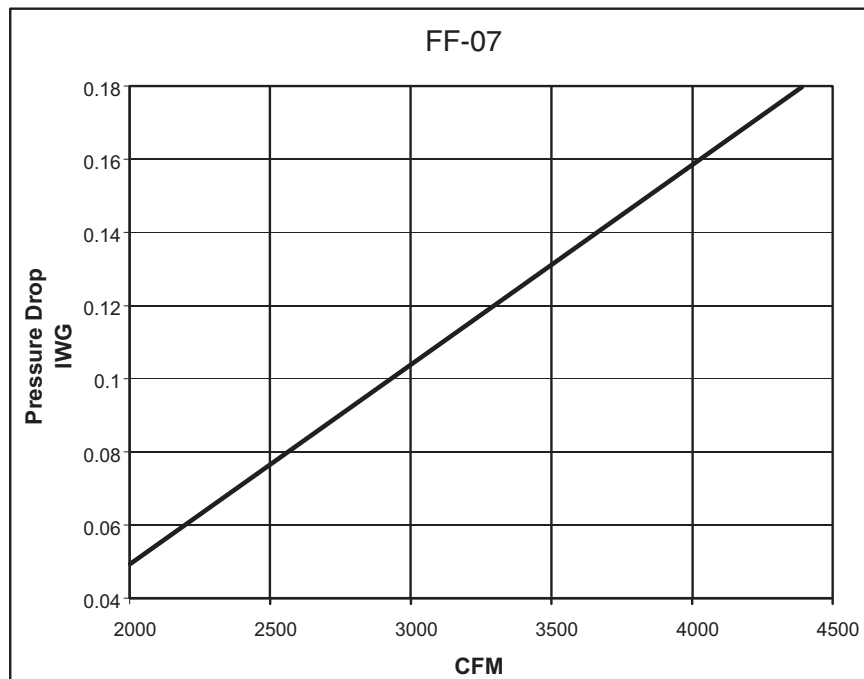

FIGURE 12 - PRESSURE DROP ACROSS A DRY INDOOR COIL VS. SUPPLY AIR CFM

TABLE 6: SUPPLY AIR BLOWER PERFORMANCE^{1 2}

ESP	7.5 Ton Heat Pump Blower Performance																	
	CFM	RPM	Watts	CFM	RPM	Watts	CFM	RPM	Watts	CFM	RPM	Watts	CFM	RPM	Watts	CFM	RPM	Watts
0.2	4152	895	1877	4014	892	1844	3725	819	1378	3443	774	1201	3219	734	1015	2949	691	855
0.4	3901	900	1752	3753	897	1714	3404	823	1255	3091	777	1084	2818	736	899	2503	694	744
0.6	3617	905	1607	3478	902	1569	3000	827	1118	2671	855	943	2149	740	762	-	-	-
0.8	3232	911	1443	3083	907	1406	2468	831	957	-	-	-	-	-	-	-	-	-
1	2740	916	1222	2431	913	1185	-	-	-	-	-	-	-	-	-	-	-	-
	0 turns			1 turn			2 turns			3 turns			4 turns			5 turns		

1. Available static pressure in IWG to overcome the resistance of the duct system and any accessories added to the unit. Refer to Tables 6 & 7 for the resistance of these accessories and for additional motor and drive data. NOTE: Refer to Form 515.41-AD1 for blower performance curves.
2. Motors can be selected to operate into the service factor because they are located in the moving air stream, upstream of any heating device.

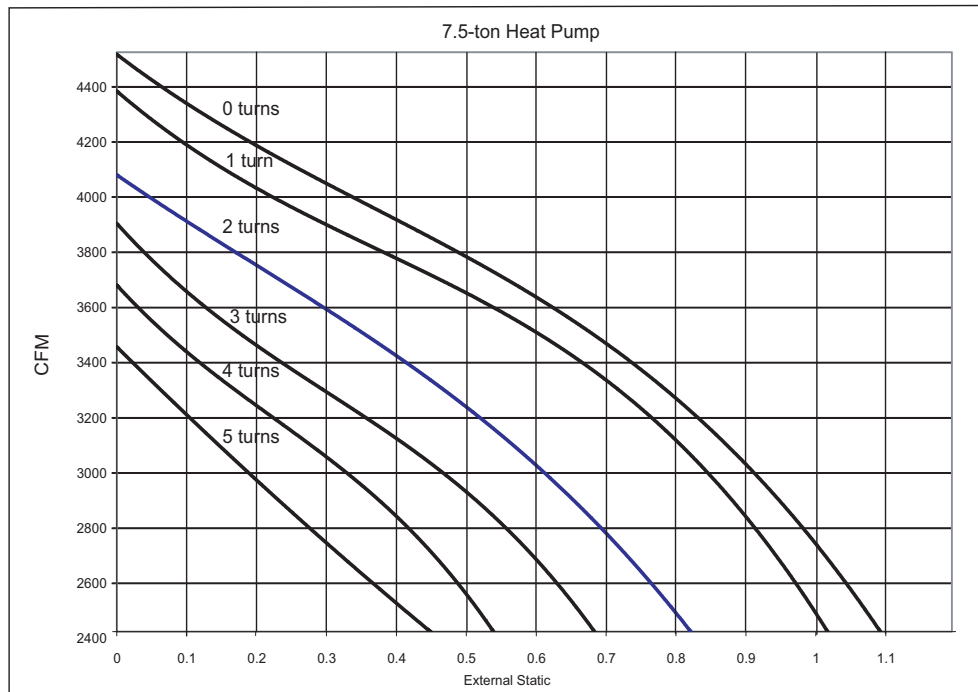

FIGURE 13 - FF-07 AIRFLOW CHART

TABLE 7: ACCESSORY STATIC RESISTANCE (IWG)

Model	Accessory	Static Resistance, IWG					
BLOWER CFM		2400	2700	3000	3300	3600	
FF-07	Electric Heat	10 KW	.01	.01	.01	.02	.02
		16 KW	.01	.02	.02	.03	.04
		26 KW	.03	.04	.05	.06	.07
		36 KW	.05	.07	.08	.10	.11
	Supply Air Plenum	.03	.03	.04	.05	.06	
Return Air Grille	.02	.03	.04	.05	.06		

(To Be Included With Duct System Static Resistance)

TABLE 8: BLOWER MOTOR AND DRIVE DATA

Model	Motor HP*	Blower RPM	Adjustable Motor Pulley		Fixed Blower Pulley		Belt	
			Pitch Dia. (Inches)	Bore (Inches)	Pitch Dia. (Inches)	Bore (Inches)	Designation	Pitch Lg. (Inches)
FF-07	1-1/2	690 - 920	2.8 - 3.8	7/8	7.5	1	A36	37.3

* These factory-mounted motors are wired for a 460V power supply. Refer to the wiring diagram inside the motor terminal box when reconnecting the motor leads for a 208 or 230 volt power supply.

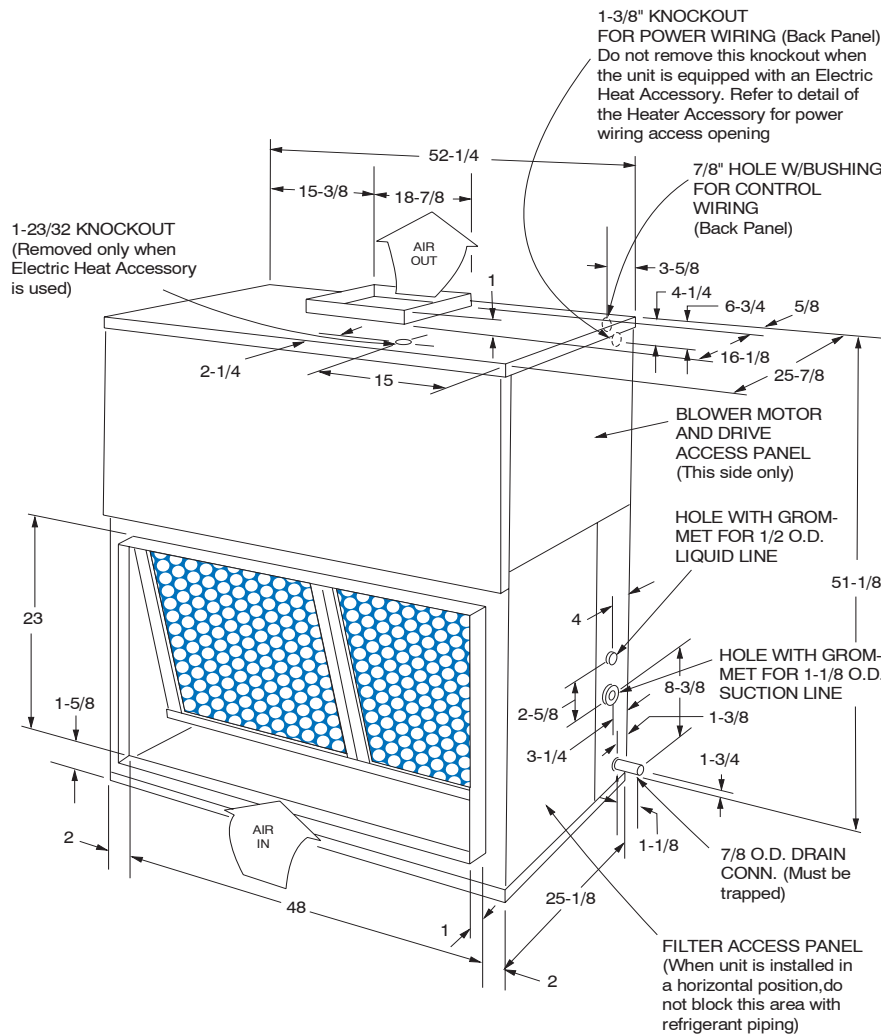

All dimensions are in inches. They are subject to change without notice. Certified dimensions will be provided upon request.

Accessories

- ELECTRIC HEATER - Add 14-14-1/4" to unit height when used.
- SUPPLY AIR PLENUM - Add 27-1/2" to unit height when used.
- BASE - Add 20" to unit height when used.

1. Overall dimensions of the unit will vary if an electric heater, a supply air plenum or a base is used.
2. This dimension is required for removal of the coil. Only 26" is required for normal service.
3. Although no clearance is required for service and operation, some clearance may be required for routing the power and control wiring.
4. Allow enough clearance to trap the condensate drain line.

Minimum Clearances	
Side with RETURN AIR opening	24"
Side with SUPPLY AIR opening	24" ¹
Side with PIPING CONNECTIONS	52" ²
Side opposite with PIPING CONNECTIONS	12"
Side with access for both POWER & CONTROL WIRING	_3
Bottom	_4

FIGURE 14 - UNIT DIMENSIONS & CLEARANCES

MAINTENANCE

INDOOR COIL

Do not allow dirt to accumulate on the indoor coil or other parts of the supply/return air circuit. Clean as often as necessary to assure good system performance. Use a brush, vacuum cleaner attachment or other suitable means.

If the coil becomes extremely dirty, it may be necessary to use an industrial grade detergent and a hose to clean the finned surfaces. This is recommended to prevent any loss in capacity and efficiency.

FILTERS

The filters must be replaced as often as necessary to assure good air flow and filtering action. Clean filters will prevent any loss in capacity and efficiency.

Refer to the unit drawing in Figure 14 for the location of the filter access panel.

DRAIN PAN

The condensate drain pan should be inspected regularly to assure proper drainage.

LUBRICATION

The bearings for the blower shaft and the blower motor are permanently lubricated and should not require any additional lubricant.

BELTS

Maintain belt tension to extend belt life. Replace when signs of failure begin to appear.

