

INSTALLATION MANUAL

CONTENTS

NOMENCLATURE.....	3
GENERAL	4
SAFETY CONSIDERATIONS	4
AGENCY APPROVALS.....	4
INSPECTION	4
INSTALLATION	5
START-UP	15
OPERATION	15
MAINTENANCE	16

See the following page for a complete Table of Contents.

NOTES, CAUTIONS AND WARNINGS

The installer should pay particular attention to the words: *NOTE*, *CAUTION*, and *WARNING*. Notes are intended to clarify or make the installation easier. Cautions are given to prevent equipment damage. Warnings are given to alert installer that personal injury and/or equipment damage may result if installation procedure is not handled properly.

CAUTION: READ ALL SAFETY GUIDES BEFORE YOU BEGIN TO INSTALL YOUR UNIT.

SAVE THIS MANUAL

SPLIT-SYSTEM CONDENSING UNITS AIR COOLED

MODEL: HF-10

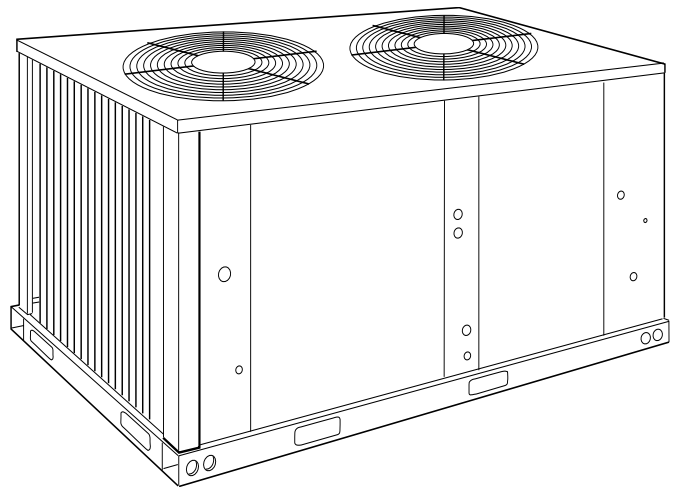

208/230/460
VOLT ONLY



TABLE OF CONTENTS

NOMENCLATURE	3	PRE-START CHECK	15
GENERAL	4	INITIAL START-UP	15
SAFETY CONSIDERATIONS	4	PHASING	15
REFERENCE	4	OPERATION	15
AGENCY APPROVALS	4	UNIT OPERATION	15
INSPECTION	4	LOW AMBIENT COOLING	16
INSTALLATION	5	SAFETY FEATURES	16
LIMITATIONS	5	MAINTENANCE	16
LOCATION	5	CLEANING CONDENSER SURFACE	16
ROOF-TOP LOCATIONS	5	LUBRICATION	16
GROUND LEVEL LOCATIONS	5	COMPRESSOR REPLACEMENT	16
RIGGING AND HANDLING	6		
CLEARANCES	7	LIST OF FIGURES	
COMPRESSORS	8	<u>Fig. #</u>	<u>Pg. #</u>
COMPRESSOR CRANKCASE HEATER	8	1 CENTER OF GRAVITY	6
POWER AND CONTROL WIRING	8	2 TYPICAL RIGGING	6
POWER WIRING	8	3 POINT LOADS	7
CONTROL WIRING	9	4 UNIT DIMENSIONS AND CLEARANCES	8
REFRIGERANT PIPING	10	5 TYPICAL FIELD WIRING WITH LF AIR HANDLER ...	9
GENERAL GUIDELINES	10	6 EXTENDING THE SERVICE PORTS	14
LINE SIZING	10	7 CHARGING CURVE FOR HF-10	14
SERVICE VALVES	11		
EXTENDING THE SERVICE PORT	12	LIST OF TABLES	
INSTALLATION	12	<u>Tbl. #</u>	<u>Pg. #</u>
EVACUATION AND CHARGING	13	1 PHYSICAL DATA	5
ALTERNATE CHARGING METHODS	13	2 UNIT APPLICATION DATA	5
START-UP	15	3 ELECTRICAL DATA	10
CRANKCASE HEATER	15	4 SUCTION LINES	11
		5 LIQUID LINES	11
		6 REFRIGERANT-22 LINE CHARGE	11

NOMENCLATURE

**PRODUCT NOMENCLATURE
OUTDOOR CONDENSING UNITS AND HEAT PUMPS
(UPG BRANDS)
H F -10 C 00 A T A AA 1 A**

Model #	Model Number Description	Options
H	Product Category	H = Air Conditioner Split System E= Split System Heat Pump
F	Product Identifier	F = R-22 Standard Efficiency 2-Pipe
-10	Nominal Cooling Capacity MBH	-07 = 7-1/2 Ton -10 = 10 Ton
C	Heat Type	C = Cooling Only
00	Nominal Heating Capacity	00 = No Heat Installed
A	Airflow Options	A = Standard Motor
T	Voltage	T = 208/230-3-60 W = 460-3-60 X = 575-3-60
A	Installation Options	A = None B = Disconnect
AA	Special Options	AA = None AC = Technicoat
1	Generation	1 = 1st Generation 2 = 2nd Generation

GENERAL

These condensing units are designed for outdoor installation on a roof or at ground level. Every unit is completely piped and wired at the factory and is shipped ready for immediate installation. Only the liquid and suction lines to the evaporator coil, the filter drier, the control wiring and the main power wiring are required to complete the installation. Each unit is dehydrated, evacuated, leak tested and pressure tested at 450 psig before being pressurized with a holding charge of refrigerant-22 for shipment and/or storage.

All controls are located in the front of the unit and are readily accessible for maintenance, adjustment and service. All wiring (power and control) can be made through the front of the unit.

SAFETY CONSIDERATIONS

The installer should pay particular attention to the words: *NOTE*, *CAUTION*, and *WARNING*. Notes are intended to clarify or make the installation easier. Cautions are given to prevent equipment damage. Warnings are given to alert installer that personal injury and/or equipment damage may result if installation procedure is not handled properly.

WARNING

Improper installation may create a condition where the operation of the product could cause personal injury or property damage.

Improper installation, adjustment, alteration, service or maintenance can cause injury or property damage. Refer to this manual for assistance or additional information, consult a qualified installer or service agency.

CAUTION

This product must be installed in strict compliance with the enclosed installation instructions and any applicable local, state, and national codes including but not limited to, building, electrical and mechanical codes.

REFERENCE

This instruction covers the installation and operation of the basic condensing unit. For information on the installation and operation of the evaporator blower units, refer to instruction Form No. 035-18876-001.

All accessories come with a separate Installation Manual.

Refer to Parts Manual for complete listing of replacement parts on this equipment.

All forms may be ordered from:

Standard Register
Toll Free Tel.: 877-318-9675
Toll Free Fax: 877-379-7920

AGENCY APPROVALS

Design certified by UL as follows:

1. For use as a cooling unit.
2. For outdoor installation only.

INSPECTION

As soon as a unit is received, it should be inspected for possible damage during transit. If damage is evident, the extent of the damage should be noted on the carrier's freight bill. A separate request for inspection by the carrier's agent should be made in writing.

TABLE 1: PHYSICAL DATA

Model Size (Mbh)	Compressor		Condenser									Unit Weight (lbs.)		Charge (Refrigerant-22 - lbs.oz.)	
			24" Fan (Propeller)			Fan Motor*				Coil					
	Rating (Tons)	Cap. (Stg's.)	Qty.	Blades /Pitch (Deg.)	Nom. CFM	Qty.	HP	RPM	Rotation**	Fins per inch	Rows Deep	Ship.	Oper.	Holding†	Oper‡
-10	10	1	2	3/26	8100	2	3/4	1110	CW	20	2	731	741	2-0	27.85

*. The ball bearing, 48 frame, single phase condenser fan motor have internal protection that is directly connected to the condenser fans. Motor rotation is counter-clockwise when viewing the lead end, which is opposite the shaft end.

†. Holding charge is the amount in the unit as shipped from the factory.

‡. Operating refrigerant charge is for the condensing unit and the matching York air handler, but does not include the charge in the interconnecting piping. See the refrigerant line charge table to determine the additional refrigerant charge required for the inter-connecting piping.

** When viewing the shaft end of the motor.

TABLE 2: UNIT APPLICATION DATA

MODEL	HA120	
Voltage Variation* Min. / Max	208/230-3-60	187 / 252
	460-3-60	432 / 504
	575-3-60	540 / 630
Ambient Air on Condenser Coil Min. / Max	Standard	45°F / 125°F
	With Head Pressure Control	0°F / 125°F

*. Rated in accordance with ARI Standard 110, utilization range "A".

INSTALLATION

LIMITATIONS

These units must be installed in accordance with all national and local safety codes. If no local codes apply, installation must conform with the appropriate national codes. See Table 2 for Unit Application Data. Units are designed to meet National Safety Code Standards. If components are to be added to unit to meet local codes, they are to be installed at the dealer's and/or the customer's expense.

LOCATION

Use the following guidelines to select a suitable location for these units.

1. The condensing unit is designed for outdoor installation only. The condenser fans are the propeller type and are not suitable for use with duct work.
2. The condensing unit and the evaporator blower should be installed as close together as possible and with a minimum number of bends in the refrigerant piping. Refer to "REFRIGERANT PIPING" for additional information.

3. The condensing unit should not be installed where normal operating sounds may be objectionable. On either rooftop or ground level installations, rubber padding can be applied between the base rails and their supports to lessen any transmission of vibration.
4. All units require certain clearances for proper operation and service. Refer to General Installation Form 55.70-M1 for additional guidelines.

ROOF-TOP LOCATIONS

Be careful not to damage the roof. Consult the building contractor or architect if the roof is bonded. Choose a location with adequate structural strength to support the unit.

The condensing unit must be mounted on solid level supports. The supports can be channel iron beams or wooden beams treated to reduce deterioration.

A minimum of two (2) beams are required to support each unit. The beams should: (1) Be positioned perpendicular to the roof joists. (2) Extend beyond the dimensions of the unit to distribute the load on the roof. (3) Be capable of adequately supporting the entire unit weight. Refer to Figure 1 and Table 1 for load distribution and weights.

These beams can usually be set directly on the roof. Flashing is not required.

NOTE: On bonded roofs, check for special installation requirements.

GROUND LEVEL LOCATIONS

The units must be installed on a one-piece level concrete slab with a minimum thickness of 4 inches. The length and width should be at least 6 inches greater than the units overall base dimensions. Refer to Figure 4.

Footers under the slab that extend below the frost line are recommended. Any strain on the refrigerant lines may cause a refrigerant leak. The slab should not be tied to the building foundation because noise and vibration will telegraph into the building.

A unit can also be supported by concrete piers. These piers should (1) extend below the frost line, (2) be located under the unit's four corners, and (3) be sized to carry the entire unit weight. Refer to Figure 1 and Table 1 for the center of gravity and unit weight.

⚠ CAUTION
Care should be taken to protect the unit from tampering and unauthorized persons from injury. Screws on access panels will prevent casual tampering. Additional safety precautions such as fences around the unit or locking devices on the panels may be advisable. Check local authorities for safety regulations.

RIGGING AND HANDLING

Exercise care when moving the unit. Do not remove any packaging until the unit is near the place of installation.

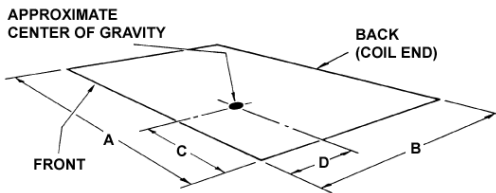

FIGURE 1 - CENTER OF GRAVITY

Unit	Dim. (In.)			
	A	B	C	D
10 Ton	76-7/8	39-7/8	38-7/8	16

Rig the unit by attaching chain or cable slings with hooks to the round lifting holes provided in the base rails.

⚠ CAUTION
Spreaders, longer than the largest dimension across the unit, must be used across the top of the unit.

Units may also be moved or lifted with a fork-lift from the front, rear or the compressor end only through the slotted openings provided in the base rails.

⚠ CAUTION
Length of forks must be a minimum of 54" when lifting from the compressor end of the unit and a minimum of 42" when lifting from the front or rear of the unit.

Remove the nesting brackets from the four corners on top of the unit. All screws that are removed to take these brackets off must be replaced on the unit.

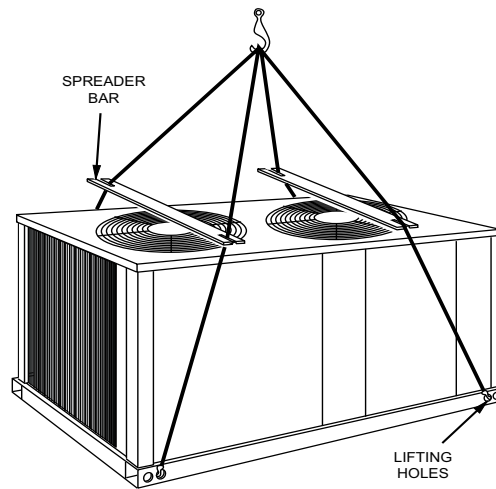

FIGURE 2 - TYPICAL RIGGING

⚠ WARNING
Before lifting the unit, make sure that its weight is distributed equally on the cables so that it will lift evenly.

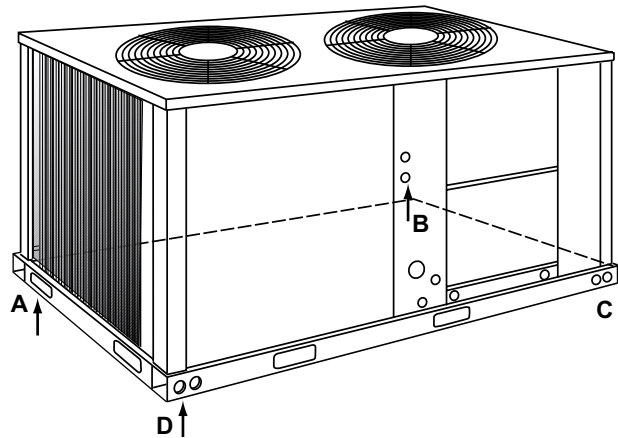

FIGURE 3 - POINT LOADS

UNIT	4-POINT LOAD (lbs)				
	TOTAL	A	B	C	D
-10	741	258	173	123	187

CLEARANCES

All units require certain minimum clearances for proper operation and service. Refer to Figure 4 for these clearances.

MINIMUM CLEARANCES	
CLEARANCE DESCRIPTION	DISTANCE IN INCHES
Overhead (Top)*	120
Front (Piping and Access Panels)	30
Left Side	24
Right Side	24
Bottom†	0

- *: Units must be installed outdoors. Overhanging structures or shrubs should not obstruct condenser air discharge.
- †: Adequate snow clearance must be provided during winter operation.

⚠ CAUTION

Do not permit overhanging structures or shrubs to obstruct condenser air discharge.

Additional height may be required for snow clearance if winter operation is expected.

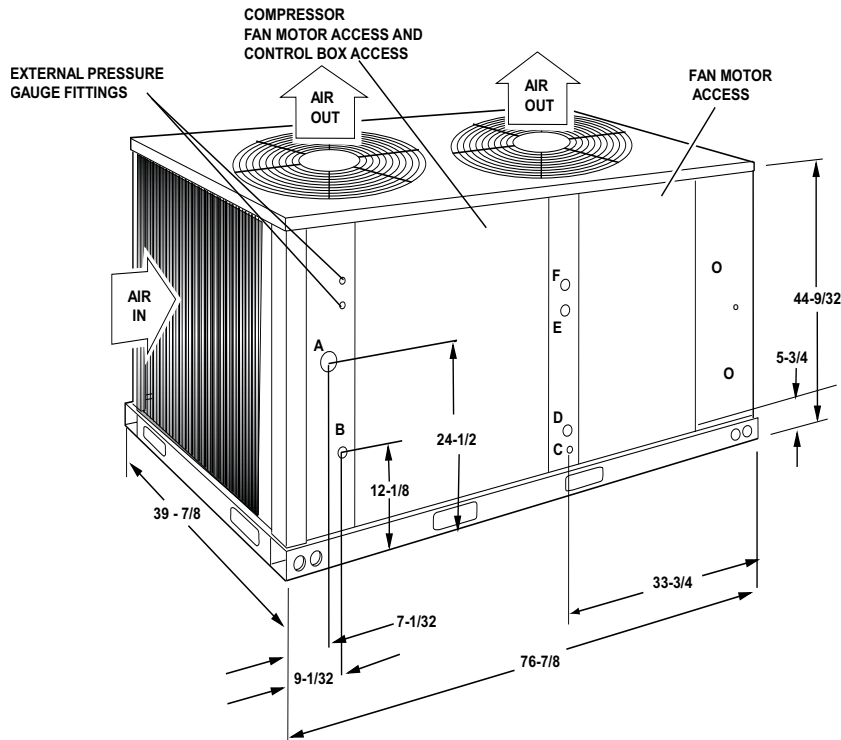

All dimensions are in inches. They are subject to change without notice. Certified dimensions will be provided upon request.

CONNECTION ENTRY	CONNECTION SIZE	
	10 Ton	
Suction Line*	A	1-3/8 OD
Liquid Line	B	5/8 OD
Control Wiring	C	7/8 KO
Power Wiring	D	1 3/8 KO
Accessory Wiring	E	7/8 KO
Accessory Wiring	F	1-3/8KO

*. Suction line is a belled fitting.

FIGURE 4 - UNIT DIMENSIONS AND CLEARANCES

COMPRESSORS

COMPRESSOR CRANKCASE HEATER

The compressor is equipped with a crankcase heater to prevent refrigerant from mixing with crankcase oil during the "OFF" cycle. The heaters will be energized when the compressor is not running providing the unit disconnect switch is closed.

CAUTION

Do not attempt to start the compressor without at least eight hours of crankcase heat or compressor damage will occur.

If a unit has just been installed or the unit disconnect switch has been open for a long period of time, move the system switch on the room thermostat to the "OFF" position before closing the unit disconnect switch. Eight hours of crankcase heat are required to drive the liquid refrigerant out of the compressor before the compressor can be started.

POWER AND CONTROL WIRING

Install electrical wiring in accordance with the latest National Electrical Code (NFPA Standard No. 70) and/or local regulations. The unit should be grounded in accordance with these codes.

POWER WIRING

Check the voltage of the power supply against the data on the unit nameplate. Check the size of the power wire, the disconnect switch and the fuses against the data on Table 3.

NOTE: Copper conductors must be installed between the disconnect switch and the unit.

Refer to Figure 4 for the location of the power wire access opening through the front of the unit. This opening will require a field-supplied conduit fitting.

The field-supplied disconnect switch must be suitable for an outdoor location. Although it should be installed near the unit, do NOT secure it to the unit cabinet.

Refer to Figure 5 for typical field wiring.

CAUTION

Units equipped with scroll compressors operate in one direction only.

Incorrect scroll compressor rotation can damage or fail the compressor(s).

Scroll compressors operate in one direction only. If a three phase scroll compressor is experiencing:

- Low amperage draw
- Similar discharge and suction pressures
- Increased noise level

then the compressor is operating in reverse. To correct this condition, switch any two (2) line voltage leads at the contactor. Please note, single phase scroll compressors will start and run in one direction only. The reverse operation is not a concern.

CONTROL WIRING

Refer to Figure 4 for the location of the control wire access opening through the front of the unit.

Route the necessary low voltage control wires (18 AWG min.) from the TB2 terminal block inside of the unit control box through this access opening to the room thermostat and to the evaporator blower motor controller.

The room thermostat should be located on an inside wall approximately 56" above the floor where it will not be subject to drafts, sun exposure or heat from electrical fixtures or appliances. Follow manufacturer's instructions enclosed with thermostat for general installation procedure.

Refer to Figure 5 for typical field wiring.

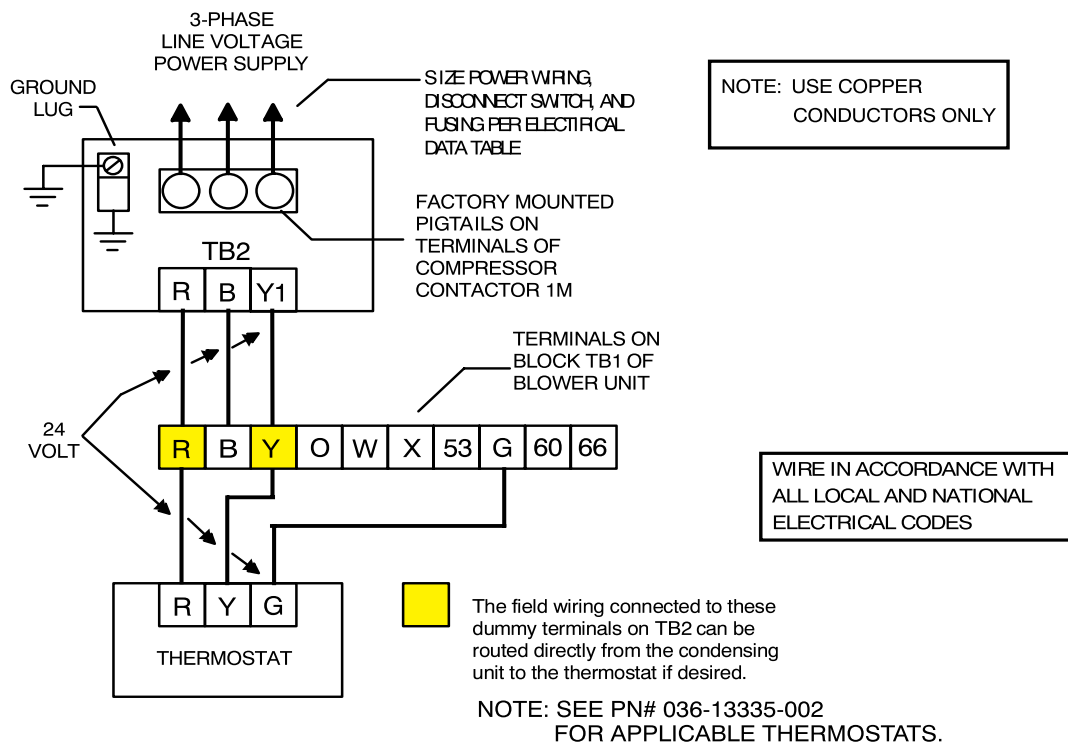

FIGURE 5 - TYPICAL FIELD WIRING WITH LF AIR HANDLER

TABLE 3: ELECTRICAL DATA

MODEL	VOLTAGE CODE	UNIT POWER SUPPLY	COMPRESSOR*		CONDENSER FAN MOTOR			UNIT			
			QTY	RLA	LRA	QTY	HP	FLA	MINIMUM CIRCUIT AMPACITY (AMPS)	MAXIMUM FUSE SIZE† (AMPS)	MINIMUM DISCONNECT SIZE‡ (AMPS)
HF-10	2	208/230/3/60	1	42.0	239.0	2	3/4	3.0	58.5	100	100
	4	460/3/60	1	19.2	125.0	2	3/4	1.6	27.2	45	45
	5	575/3/60	1	13.8	80.0	2	3/4	1.4	20.1	30	30

* The 208-230 V compressors and motors use a single tap for the entire range of voltages. The 208/230 V to 24 V transformers have different taps for 208 and 230 V.

† Dual element, time delay type.

‡ Refer to article NEC/NFPA No. 70, articles 440-11,12 for information on minimum disconnect sizing.

REFRIGERANT PIPING

GENERAL GUIDELINES

Many service problems can be avoided by taking adequate precautions to provide an internally clean and dry system and by using procedures and materials that conform with established standards.

Use hard drawn copper tubing where no appreciable amount of bending around pipes or other obstructions is necessary. Use long radius ells wherever possible with one exception—short radius ells for the traps in all suction risers. If soft copper is used, care should be taken to avoid sharp bends which may cause a restriction.

Pack fiberglass insulation and a sealing material such as permagum around refrigerant lines where they penetrate a wall to reduce vibrations and to retain some flexibility.

Support all refrigerant lines at minimum intervals with suitable hangers, brackets or clamps.

Braze all copper to copper joints with Silfos-5 or equivalent brazing material. Do not use soft solder.

Insulate all suction lines with a minimum of 1/2" ARMA-FLEX or equal. Liquid lines exposed to direct sunlight and/or high temperatures must also be insulated.

Never solder suction and liquid lines together. They can be taped together for convenience and support purposes, but they must be completely insulated from each other.

A filter-drier **MUST** be installed in the liquid line of every system to prevent dirt and moisture from damaging the system. A properly-sized filter-drier is shipped with each condensing unit for field installation near the evaporator coil. The filter-drier is shipped inside the unit control box.

NOTE: Installing a filter-drier does not eliminate the need for the proper evacuation of a system before it is charged.

A moisture indicating sight-glass may be field installed in liquid line(s) between the filter-drier and the evaporator coil. The moisture indicating sight-glass can be used to check for excess moisture in the system or used as visual means to verify refrigerant charge.

LINE SIZING

When sizing refrigerant lines for a split-system air conditioner, check the following:

1. Suction line pressure drop due to friction at full capacity
2. Liquid line pressure drop due to friction at full capacity
3. Suction line velocity for oil return at part capacity
4. Liquid line pressure drop due to static head.

NOTE: Never base refrigerant line sizes on the OD of the suction and liquid connections on the unit.

Tables 4 and 5 list friction losses for both the suction and liquid lines on the system. Table 6 shows the amount of refrigerant charge required per foot of refrigerant line.

When the evaporator coil is below the condensing unit, the suction line must be sized for both pressure drop and for oil return. For certain piping arrangements, different suction line sizes may have to be used. The velocity of the suction gas must always be great enough to carry oil back to the compressor.

When the condensing unit is below the evaporator coil, the liquid line must be designed for the pressure drop due to both friction loss and vertical rise. If the total pressure drop exceeds 40 psi, some refrigerant may flash before it reaches the thermal expansion valve.

This flashing will not only cause erratic valve operation and poor system performance, but could also damage the expansion valve.

SERVICE VALVES

These condensing units have service valves on the compressor suction line and on the liquid line leaving the condenser coil.

The liquid and suction line service valves are shipped from the factory front-seated and closed with the valve stem in the maximum clockwise position.

The liquid and suction line service valves have a 1/4" male flare access port for evacuating, charging and pressure checking the system.

NOTE: Never remove a cap from an access port unless the valve is fully back-seated with its valve stem in the maximum counter-clockwise position because the refrigerant charge will be lost. Always use a refrigeration valve wrench to open and close these service valves.

TABLE 4: SUCTION LINES*

MODEL DESIGNATION		NOMINAL CAPACITY (TONS)	REFRIGERANT FLOW RATE †(LBS./MIN.)	TYPE L COPPER TUBING (INCHES O.D.)	REFRIGERANT GAS VELOCITY (FT./MIN.)	FRICITION LOSS‡ (PSI/100 FT.)
HF-10	Full Capacity	10	30	1-3/8	2280	2.8

* All horizontal suction lines should be pitched at least 1 inch every 20 ft. in the direction of the refrigerant flow to aid the return of oil to the compressor. Every vertical riser greater than 3 ft. in height should have a "P" trap at the bottom to facilitate the return of oil to the compressor. Use short radius fittings for these traps.

† Based on Refrigerant-22 at the nominal capacity of the condensing unit, a suction temperature of 40°F and a liquid temperature of 105°F.

‡ Although suction lines should be sized for a friction loss equivalent to a 2°F change in saturation temperature (or approximately 3 PSI), sizing the lines for the proper return of oil is more important. These friction losses do not include any allowances for valves or fittings.

TABLE 5: LIQUID LINES

MODEL DESIGNATION	NOMINAL CAPACITY (TONS)	REFRIGERANT FLOW RATE	TYPE L COP- PER TUBING (INCHES O.D.)	PRESSURE DROP*	
				FRICITION (PSI/100 FT.)	VERTICAL RISE (PSI/FT.)
HF-10	10	30	5/8	5.8	0.5

* The total pressure drop of the liquid line for both friction and vertical rise must not exceed 40 PSI. If the pressure drop exceeds 40 PSI, the liquid refrigerant could flash before it reaches the expansion valve. This flashing will only cause erratic valve operation and poor system performance, but could also damage the expansion valve.

TABLE 6: REFRIGERANT-22 LINE CHARGE*

Liquid Line Inches, O.D.†	5/8	0.113 lb./ft.
Suction Line Inches, O.D.†	1-3/8	0.013lb./ft.

* Charges are based on 40°F suction temperature and a 105°F liquid temperature

† Type "L" copper tubing

Note: Add the operating charge of the condensing unit, the evaporator coil and the refrigerant lines to determine the total refrigerant charge of the system.

EXTENDING THE SERVICE PORT

1. Loosen the screws that secure the service ports in shipping position.
2. Push the service ports through the corner post.
3. Tighten the screws to secure the service ports for installation.

INSTALLATION

Since the condensing units are shipped with a holding charge of Refrigerant-22, they can be checked for a refrigerant leak by depressing the stem on either of the service ports that extend through the cabinet. As soon as some internal pressure is relieved release the stem. **DO NOT** release the entire holding charge.

If the unit has already lost its holding charge, it should be leak tested and the necessary repairs should be made. If the unit has maintained its holding charge, you can assume that it has no leaks and proceed with the installation.

CAUTION

Dry nitrogen should always be supplied through a connection while it is being brazed or unbrazed because the temperature required to make or break a brazed joint is sufficiently high to cause oxidation of the copper unless an inert atmosphere is provided. The flow of nitrogen should be continued until the joint has cooled.

When making a braze connection, wrap a wet rag around all tubing inside the unit to help prevent damage to other components.

WARNING

The dry nitrogen should always be supplied through a pressure regulating valve.

1. Burnish the external surfaces of the liquid connection on the condensing unit and the end of the field-supplied piping for the liquid line.

NOTE: Clean surfaces are essential for a well-brazed connection.

2. Carefully clean the internal surfaces of the above. Any particles left on these surfaces may lead to a future system malfunction.

NOTE: Use only copper tubing that has been especially cleaned and dehydrated for refrigerant use. If the tubing has been open for an extended period of time, it should be cleaned before being used.

The liquid line connections can now be brazed while maintaining a minimum flow of dry nitrogen through the piping as follows:

1. Remove the cap from the 1/4" access port on the liquid line service valve.
2. Connect a supply of dry nitrogen to this access port.

NOTE: The filter-drier should be installed in the liquid line as close to the evaporator coil as possible.

Do not allow the filter-drier to be exposed to the atmosphere for an extended period of time. Once it absorbs moisture from the atmosphere, it loses its effectiveness.

3. The matched air handlers are shipped with a small R-22 charge and the should be checked for leaks before installation. Drill a small hole through the sealing cap or disc in both the liquid and suction connection. If there is a pressure release, the evaporator has no leaks and you can proceed with installation. If the charge has been lost, the coils should be leak tested and the necessary repairs made.
4. Move the dry nitrogen supply from the access port on the liquid line service valve of the condensing unit to the hole through the suction disc on the evaporator coil.
5. Unbrazed the coil's liquid line disc while maintaining a flow of dry nitrogen across the connection and through the hole in the liquid line disc.

NOTE: If the liquid line has a solenoid valve, the valve should be opened manually to permit the nitrogen to flow freely.

6. After the disc has been removed, burnish the external surfaces and clean the internal surfaces as outlined above.
7. Move the dry nitrogen supply back to the access port on the liquid line service valve.
8. Braze the liquid line to the liquid connection on the evaporator coil while maintaining a minimum flow of dry nitrogen through the liquid line, the evaporator coil and the hole in the suction disc.

9. Unbraid the disc on the suction connection of the evaporator coil while maintaining the flow of dry nitrogen.
10. After the disc has been removed, burnish the external surfaces and clean the internal surfaces as outlined above.

The suction piping can now be brazed to the suction connection on the evaporator coil while maintaining a minimum flow of dry nitrogen.

Before brazing the suction line to the condensing unit:

1. Move the dry nitrogen supply to the access port on the suction service valve of the condensing unit.
2. Burnish the external surfaces and clean the internal surfaces of both the suction connection and the suction piping.

The suction line can now be brazed to the suction connection on the condensing unit while maintaining the flow of dry nitrogen.

After the liquid and suction lines have been installed, the system should be evacuated and charged.

EVACUATION AND CHARGING

With the liquid and suction line service valves closed, connect a vacuum pump through a charging manifold to the access ports on both the liquid and suction line service valves.

NOTE: The vacuum pump connection should be short and no smaller than 3/8" O.D.

The refrigerant lines and the evaporator coil must now be evacuated to 500 microns without disturbing the charge in the condenser coil or the compressor.

After proper evacuation and dehydration, charge refrigerant through the access port on the liquid line service valve allowing the vacuum to draw in as much refrigerant as possible.

CAUTION

Do not charge liquid refrigerant through the compressor suction connection.

CAUTION

Do not attempt to start the compressor without at least 8 hours of crankcase heat or compressor damage will occur.

To continue charging refrigerant, open the liquid and the suction line service valves fully. Turn the stem of the liquid service valve clockwise 1/4 turn to open its access port for reading pressure.

Start the compressor (after 8 hours of crankcase heat), turn the stem of the suction line service valve clockwise 1/4 turn to open its service port and continue to charge refrigerant gas through this suction access port until you meet the conditions shown on the charging curve, Figure 7.

Open the liquid and vapor line service valves fully to close their access ports after the system has been charged.

ALTERNATE CHARGING METHODS

If you are starting a unit when the ambient temperature is higher or lower than those shown in Figure 7, either of the following methods may be used.

Method 1: Determine the total weight of the refrigerant for the total system by adding the required charge for the outdoor unit, the indoor unit and the refrigerant lines using information in Tables 1 (Physical Data) and 6 (Refrigerant Line Charge).

Using the charging procedures outlined above, weigh the required amount of refrigerant charge into the unit.

Method 2: Install a field supplied moisture indicating sight glass in the liquid line between the filter-drier and the evaporator coil.

Using the charging procedure outlined above, charge refrigerant until the moisture indicating sight glass is clear. Add approximately 2 extra pounds of refrigerant to assure a liquid refrigerant seal at the expansion valve under all operating conditions. Block the flow of the condenser air, if necessary, to assure a head pressure of 280 psig during the charging procedure.

NOTE: The installer should return to the job to verify the operating charge when the ambient temperature is within the conditions shown in Figure 7.

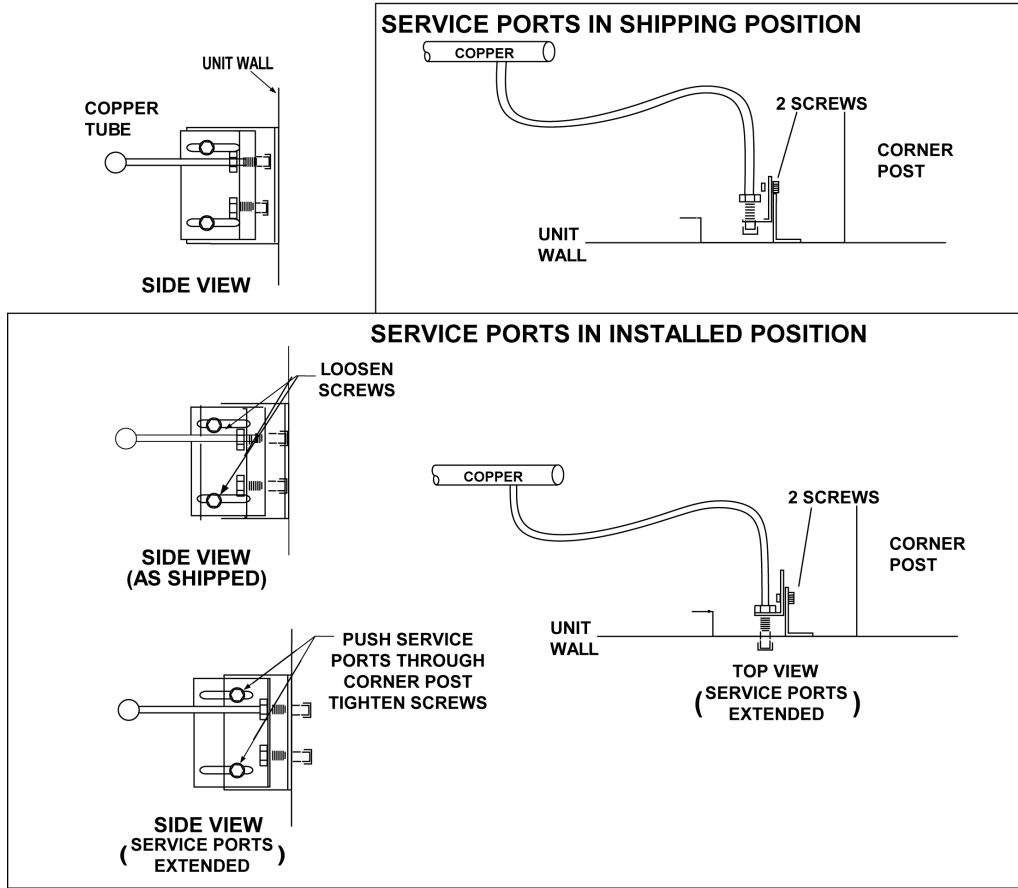

FIGURE 6 - EXTENDING THE SERVICE PORTS

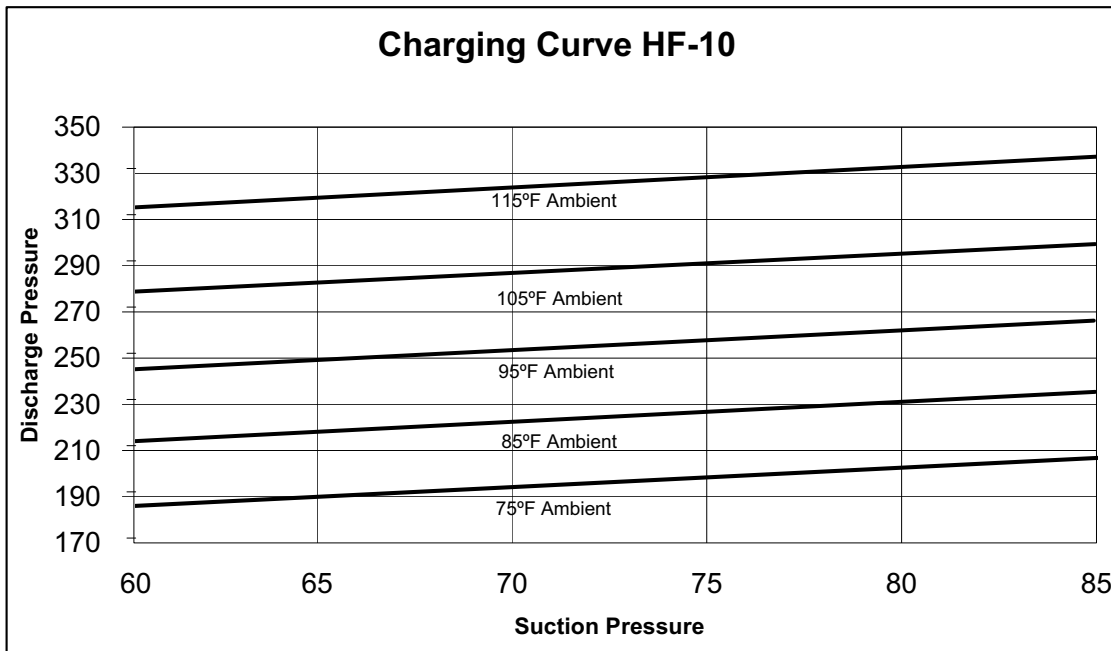

FIGURE 7 - CHARGING CURVE FOR HF-10

START-UP

CRANKCASE HEATER

The crankcase heater must be energized at least 8 hours before starting the compressor. To energize the crankcase heater, the main disconnect switch must be closed. During this 8 hour period, the system switch on the room thermostat must be "OFF" to prevent the compressor from starting. Make sure that the bottom of the compressor is warm to the touch to prove crankcase heater operation.

CAUTION

Do not attempt to start the compressor without at least 8 hours of crankcase heat or compressor damage can occur.

PRE-START CHECK

Before starting the unit, complete the following check list:

1. Have sufficient clearances been provided?
2. Has all foreign matter been removed from the interior of the unit (tools, construction or shipping materials, etc.)?
3. Have the condenser fans been rotated manually to check for free rotation?
4. Are all wiring connections tight?
5. Does the available power supply agree with the nameplate data on the unit?
6. Is the control circuit transformer set for the proper voltage?
7. Have the fuses, disconnect switch and power wire been sized properly?
8. Are all compressor hold-down nuts properly secured?
9. Are any refrigerant lines touching each other or any sheet metal surface? Rubbing due to vibration could cause a refrigerant leak.
10. Are there any visible signs of a refrigerant leak, such as oil residue?
11. Is any electrical wire laying against a hot refrigerant line?

INITIAL START-UP

1. Supply power to the unit through the disconnect switch at least 8 hours prior to starting the compressor.

2. Move the system switch on the thermostat to the AUTO or COOL position.
3. Reduce the setting of the room thermostat to energize the compressor.
4. Check the operation of the evaporator unit per the manufacturer's recommendations.
5. With an ammeter, check the compressor amps against the unit data plate.
6. Check for refrigerant leaks.
7. Check for any abnormal noises and/or vibrations, and make the necessary adjustments to correct (e.g. fan blade(s) touching shroud, refrigerant lines hitting on sheet metal, etc.)
8. After the unit has been operating for several minutes, shut off the main power supply at the disconnect switch and inspect all factory wiring connections and bolted surfaces for tightness.

PHASING

CAUTION

Units equipped with scroll compressors operate in one direction only.

Incorrect scroll compressor rotation can damage or fail the compressor(s).

Scroll compressors operate in one direction only. If a three phase scroll compressor is experiencing:

- Low amperage draw
- Similar discharge and suction pressures
- Increased noise level

then the compressor is operating in reverse. To correct this condition, switch any two (2) line voltage leads at the contactor. Please note, single phase scroll compressors will start and run in one direction only. The reverse operation is not a concern.

OPERATION

UNIT OPERATION

When the external control calls for cooling at terminal:

1. The system controller (SC) is energized. The system controller starts the compressor and enables the condenser fans by energizing contactor 1M (and 2M on the 208/230 volt models).

Condenser fan motor #1 is energized with the compressor. Fan motor #2 operation is controlled through the Pressure Switch (PS) which will de-energize the motor when the discharge pressure falls below 180 PSI. The motor will be energized when the discharge pressure reaches 280 PSI.

2. Safety Lockout: The system controller (SC) has a lockout circuit to prevent compressor short-cycling on a safety control with automatic reset. If the high or low refrigerant pressure switches (HP or LP) open, the SC will enter lockout mode.

SC provides a 90 second bypass of the low pressure switch LP to prevent nuisance lockouts during unit start-up.

A malfunction light (24V, 2 A max. resistive load) can be energized through SC, by connecting the light between terminals X and B on TB1. Terminal X will energize when SC locks out.

3. Unit is equipped with an anti-short cycle timer to prevent two successive compressor starts within 5 minutes. If the compressor fails to start with a call for cooling and SC is not locked out, wait at least 6 minutes for the anti-cycle timer to reset.

NOTE: To reset the unit after a lockout:

- A. Turn the system switch on the thermostat to the "OFF" position and back to the "COOL" position.

OR

- B. Increase the set point of the room thermostat above the temperature in the conditioned space and return it to its original setting.

If the unit continues to be shut down by one of its safety controls, service should be called to determine the cause of the problem. Repeatedly resetting the lockout circuit may damage the unit.

LOW AMBIENT COOLING

The following accessories are available to provide low ambient operation to 0°F:

2LA04702025	208/230 VOLTS
2LA047022146	460 VOLTS
2LA04701958	575 VOLTS

SAFETY FEATURES

1. All condenser fan motors have inherent protection with automatic reset.
2. Every compressor is internally protected against over current, excessive temperature and primary single phasing.

This protection is provided by a line break motor protector that is mounted inside the compressor housing and is connected between each winding and the common terminal.

3. Every compressor is protected by crankcase heaters to prevent refrigerant from accumulating in the crankcases of the compressor during an "OFF" cycle.
4. All condenser fan motors and the secondary of every transformer is grounded.
5. Every unit is protected by both a high and a low pressure control, and these controls are self-contained. Since they are mounted directly on the access connections and wired back to the control panel, there are no capillary lines to be damaged.

MAINTENANCE

CLEANING CONDENSER SURFACE

Dirt should not be allowed to accumulate on the condenser coils or other parts in condenser air circuit. Clean as often as necessary with a brush, vacuum cleaner attachment or other suitable means.

LUBRICATION

The fan motors for these condensing units are equipped with factory lubricated and sealed all bearings. They do not require any maintenance.

COMPRESSOR REPLACEMENT

Contact the local UPG Distribution Center for compressor or parts.