

INSTALLATION INSTRUCTION

ELECTRIC HEATER ACCESSORY MODELS 2NH045005 THRU 2NH045025, 2NP045010 THRU 2NP045025, 2ND04501506, AND 2NX04502506

Supersedes: 035-16605-003-D-0405

035-16605-003-E-0705

GENERAL

This instruction covers the installation of the following electric heaters:

2ND04501506, 2NH04500506, 2NH04500706, 2NH04501006, 2NH04501506, 2NH04502006, 2NH04502506, 2NH04501025, 2NH04501525, 2NH04502025, 2NH04502525, 2NH04501046, 2NH04501546, 2NH04502046, 2NH04502546, 2NH04501058, 2NH04501558, 2NH04502058, 2NH04502558, 2NP04501006, 2NP04501025, 2NP04501046, 2NP04501506, 2NP04501525, 2NP04501546, 2NP04502006, 2NP04502025, 2NP04502506, 2NP04502525, 2NP04502046, 2NP04502546, 2NP04502058, 2NP04502558, 2NX04502506

The electric heat accessories are used for applications of cooling with electric heat and heat pump with electric heat. Each of the unit models are approved for use with specific electric heat accessories. Tables 1 through 6 list the possible combinations and other important electrical data and limitations. Refer to the unit wiring diagram during installation.

CAUTION: Unit is approved for zero clearance to combustible material and when equipped with electric heat a minimum clearance of one inch must be maintained on all sides of the supply duct and/or plenum for three feet as shown in the detail in Figure 1 for the 20 kw and 25 kw electric heaters only.

NOTE:

FOR UNITS APPLIED WITH A ROOF CURB, THE MINIMUM CLEARANCE MAY BE REDUCED FROM 1 INCH TO 1/2 INCH BETWEEN COMBUSTIBLE ROOF CURB MATERIAL AND THE SUPPLY DUCT.

MINIMUM CLEARANCE OF 1" ALL SIDES FOR THE FIRST 3' OF DUCT FOR 20 & 25 KW. ZERO INCHES THEREAFTER, FOR ALL OTHER HEATERS, ZERO INCH CLEARANCE ALL SIDES FOR ENTIRE LENGTH OF DUCT.

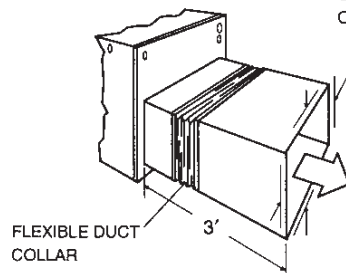

FIGURE 1 - CLEARANCES

NOTE: The electric heat accessory should be installed before the supply air duct is attached to the supply air opening flanges.

INSTALLATION

Install the electric heater accessory as follows:

1. Disconnect all electric power to unit.
2. Remove the indoor blower/electric heat compartment access panel and the unit control box access panel.
3. From the plenum side, remove and discard the patch plate exposing the opening for installation of the electric heat accessory. For the 4 and 5 ton units, remove patch plate 1 for the 5 kW through 15 kW heaters or patch plates 1 and 2 for 20 kW or 25 kW heaters. See Figure 2. Save four screws for Step 6.

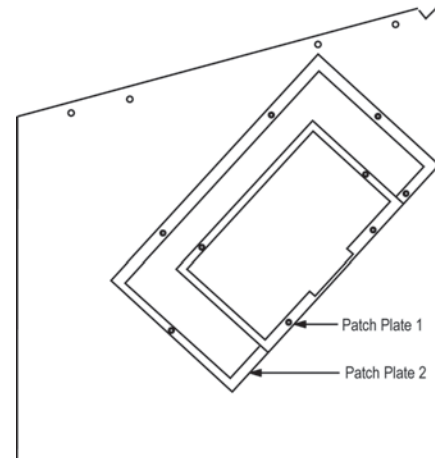

FIGURE 2 - PATCH PANEL PLATE 1 & 2

4. Install the element support bracket with the two sheet metal screws provided as shown in Figure 3.
5. Install the electric heat accessory.

CAUTION: To prevent damage, carefully pass the accessory heating element through the rectangular opening in the plenum side. The heating element support rods must be seated in the hole in the element support bracket, see Figure 3.

6. Align holes and fasten the accessory to the plenum side with the screws removed from the patch plate in step 3.

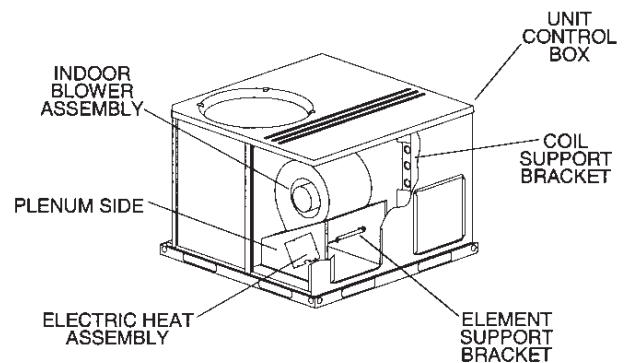

FIGURE 3 - ELECTRIC HEATER MOUNTING

7. Route the high voltage harness, the end without the plug, behind the indoor blower assembly using the wire clip with the base unit, and through the coil support bracket. See Figure 3.
8. Install the fuse block or terminal block assembly in the control box as shown in Figure 4, 5 or 6 using the sheet metal screws provided.

NOTE: For 460/575 Volt units with the indoor blower transformer mounted in the control box, remove the terminal block from the mounting plate before installing the terminal block. Discard the mounting plate.

9. For the 2ND04501506 model, mount the grounding lug inside the control box with the sheet metal screw provided.
10. Route the appropriate wires from the fuse holder or terminal block to the M1 contactor as indicated in the unit wiring diagram.
11. Route the high voltage wiring harness from step 7 to the fuse holder and connect to the appropriate fuses identified in the unit wiring diagram. Install a wire tie in the hole next to the extruded opening in the control box and secure the wire harness.
12. Remove wire 204 from the 6-pin receptacle on the electric heat/fan control board in the control box.
13. Route the high voltage wiring harness (with the 4-pin plug P3) and the low voltage wiring harness (with the 6-pin plug P2) from step 7 into the control box and plug into the electric heat/fan control board. Install a wire tie in the hole next to the extruded opening in the control box and secure the wire harness.
14. Route the power supply wiring to the fuse holder as outlined in the unit installation instructions. See appropriate table in

the following pages for electrical requirements.

15. For three-phase applications, install the electric heat cover over the contactor/relay with the screws supplied.
 16. Replace the indoor blower/electric heat compartment access panel and the unit control box access panel.
- NOTE:** All wiring must comply with local and national electrical code requirements. Read and heed all unit caution labels.
17. Mark the appropriate box on the unit nameplate for the particular heater installed.
 18. Reconnect the power to the unit after making certain that the field wiring size satisfies minimum requirements for specific combinations of unit/heater installed and the indoor blower speed tap is connected to at least the minimum speed, identified on unit nameplate.

NOTE: The electric heaters have a thermal limit control. If failure occurs, this limit control must be replaced with the identical part number.

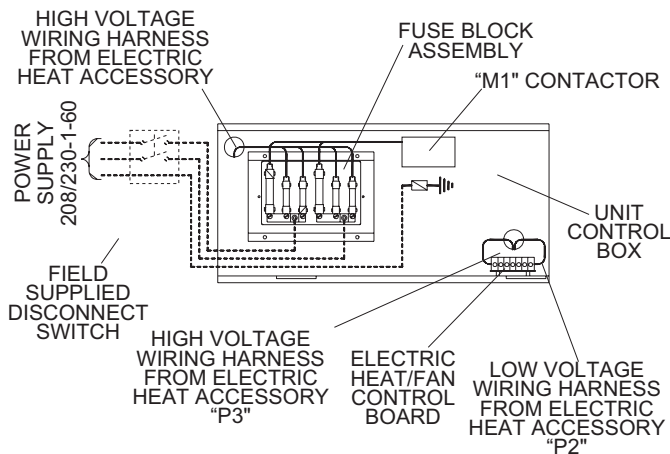

FIGURE 4 - TYPICAL SINGLE POINT 208/230-1-60 FIELD WIRING

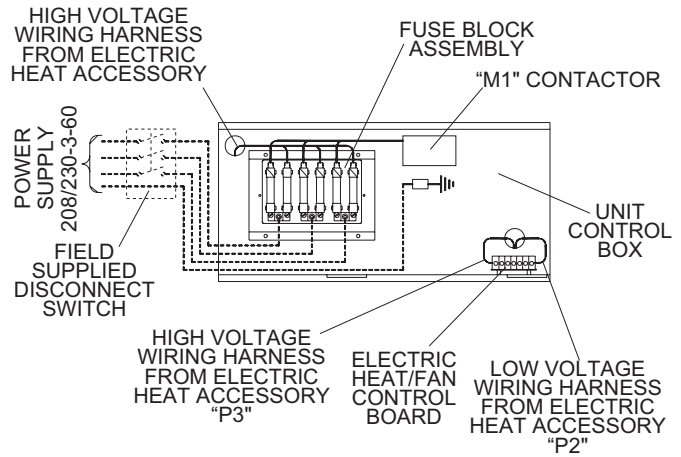

FIGURE 5 - TYPICAL SINGLE POINT 208/230-3-60 FIELD WIRING

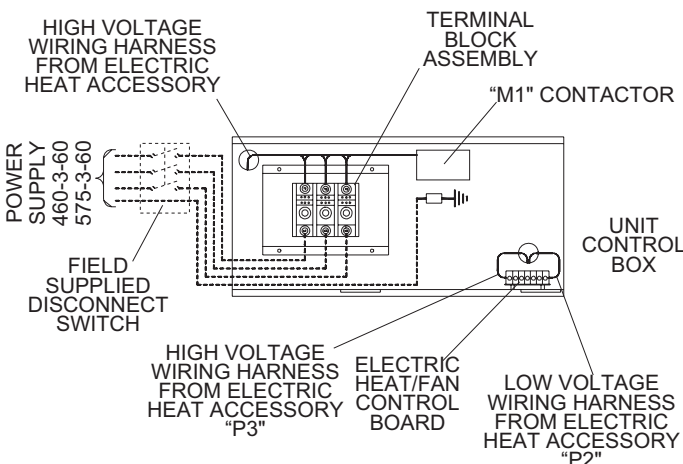

FIGURE 6 - TYPICAL SINGLE POINT 460/575-3-60 FIELD WIRING

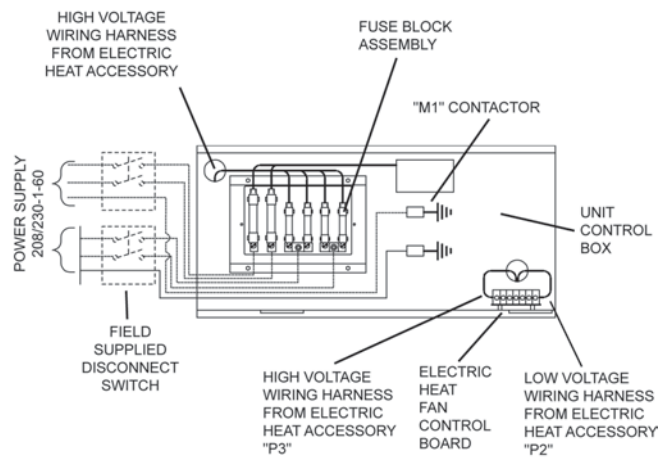

FIGURE 7 - TYPICAL DUAL POINT 208/230-1-60 FIELD WIRING

TABLE 1 - ELECTRICAL DATA (10 SEER COOLING / ELECTRIC HEAT)

MODEL DEB/DFB	POWER SUPPLY	COMPRESSOR		COND. FAN MOTOR FLA	SUPPLY AIR BLOWER MOTOR, FLA	ELECTRIC HEAT ACCESSORY				MINIMUM CIRCUIT AMPACITY	MAX. FUSE SIZE, ¹ AMPS	MAX. HACR ² BREAKER SIZE
		RLA	LRA			MODEL NO.	STAGE	KW	TOTAL AMPS			
018	208/230-1-60	9.0	48.0	1.1	2.6	2NH04500506	1	3.8/5.0 *	18.1/20.8	25.8/29.3	30/30	30/30
						2NH04500706	2	5.6/7.5 *	27.1/31.3	37.1/42.3	40/45	40/45
024	208/230-1-60	11.2	60.0	1.1	2.6	2NH04500506	1	3.8/5.0 *	18.1/20.8	25.8/29.3	30/30	30/30
						2NH04500706	2	5.6/7.5 *	27.1/31.3	37.1/42.3	40/45	40/45
						2NH04501006	2	7.5/10.0 *	36.1/41.7	48.4/55.3	50/60	50/60
030	208/230-1-60	14.7	73.0	1.1	2.6	2NH04500506	1	3.8/5.0 *	18.1/20.8	25.8/29.3	30/30	30/30
						2NH04500706	2	5.6/7.5 *	27.3/31.3	37.1/42.3	40/45	40/45
						2NH04501006	2	7.5/10.0 *	36.1/41.7	48.4/55.3	50/60	50/60
						2NH04501506	2	11.3/15.0 *	54.2/62.5	71.0/81.4	80/90	80/90
036	208/230-1-60	17.3	94.0	1.1	3.5	2NH04501006	2	7.5/10.0 *	36.1/41.7	49.5/56.5	50/60	50/60
						2NH04501506	2	11.3/15.0 *	54.2/62.5	72.1/82.5	80/90	80/90
042	208/230-1-60	20.5	120.0	1.1	3.5	2NH04500506	1	3.8/5.0 *	18.1/20.8	30.2/30.4	40/40	40/40
						2NH04500706	2	5.6/7.5 *	27.1/31.3	38.2/43.4	50/50	50/50
						2NH04501006	2	7.5/10.0 *	36.1/41.7	49.5/56.5	50/60	50/60
						2NH04501506	2	11.3/15.0 *	54.2/62.5	72.1/82.5	80/90	80/90
048	208/230-1-60	24.4	140.0	1.3	4.0	2NH04501006	2	7.5/10.0 *	36.1/41.7	50.1/57.1	60/60	60/60
						2NH04501506	2	11.3/15.0 *	54.2/62.5	72.1/83.1	80/90	80/90
						2NH04502006	2	15.0/20.0 *	72.2/83.3	95.3/109.2	100/110	100/110
						2NH04502506	2	18.8/25.0 *	90.3/104.2	117.8/135.2	125/150	125/150
060	208/230-1-60	28.9	165.0	1.3	7.0	2NH04501006	2	7.5/10.0 *	36.1/41.7	53.9/60.8	70/70	70/70
						2NH04501506	2	11.3/15.0 *	54.2/62.5	76.5/86.9	80/90	80/90
						2NH04502006	2	15.0/20.0 *	72.2/83.3	99.0/112.9	100/125	100/125
						2NH04502506	2	18.8/25.0 *	90.3/104.2	121.6/139.0	125/150	125/150
036	208/230-3-60	10.9	78.0	1.1	3.5	2NH04501025	1	7.5/10.0 *	20.8/24.1	30.4/34.4	35/35	35/35
						2NH04501525	1	11.3/15.0 *	31.3/36.1	43.5/49.5	45/50	45/50
042	208/230-3-60	14.1	110.0	1.1	3.5	2NH04501025	1	7.5/10.0 *	20.8/24.1	30.4/34.4	35/35	35/35
						2NH04501525	1	11.3/15.0 *	31.3/36.1	43.5/49.5	45/50	45/50
048	208/230-3-60	14.1	105.0	0.7	4.0	2NH04501025	1	7.5/10.0 *	20.8/24.1	31.1/35.1	35/40	35/40
						2NH04501525	1	11.3/15.0 *	31.3/36.1	44.1/50.1	45/60	45/60
						2NH04502025	2	15.0/20.0 *	41.7/48.1	57.1/65.1	60/70	60/70
						2NH04502525	2	18.8/25.0 *	52.1/60.1	70.2/80.2	80/90	80/90
060	208/230-3-60	16.0	125.0	1.3	7.0	2NH04501025	1	7.5/10.0 *	20.8/24.1	34.8/38.8	40/40	40/40
						2NH04501525	1	11.3/15.0 *	31.3/36.1	47.8/53.9	50/60	50/60
						2NH04502025	2	15.0/20.0 *	41.7/48.1	60.9/68.9	70/70	70/70
						2NH04502525	2	18.8/25.0 *	52.1/60.1	73.9/83.9	80/90	80/90
036	460-3-60	5.8	40.0	0.6	1.8	2NH04501046	1	10.0 **	12.0	17.3	20	20
						2NH04501546	1	15.0 **	18.0	24.8	25	25
042	460-3-60	7.1	54.0	0.6	1.8	2NH04501046	1	10.0 **	12.0	17.3	20	20
						2NH04501546	1	15.0 **	18.0	24.8	25	25
048	460-3-60	7.1	55.0	0.6	2.0	2NH04501046	1	10.0 **	12.0	17.5	20	20
						2NH04501546	1	15.0 **	18.0	25.1	30	30
						2NH04502046	2	20.0 **	24.1	32.6	35	35
						2NH04502546	2	25.0 **	30.1	40.1	45	45
060	460-3-60	8.0	67.0	0.7	3.5	2NH04501046	1	10.0 **	12.0	19.4	20	20
						2NH04501546	1	15.0 **	18.0	26.9	30	30
						2NH04502046	2	20.0 **	24.1	34.4	35	35
						2NH04502546	2	25.0 **	30.1	42.0	45	45
036	575-3-60	4.5	32.0	0.4	1.5	2NH04501058	1	10.0 ***	9.6	13.9	15	15
						2NH04501558	1	15.0 ***	14.4	19.9	20	20
042	575-3-60	5.8	44.0	0.4	1.5	2NH04501058	1	10.0 ***	9.6	13.9	15	15
						2NH04501558	1	15.0 ***	14.4	19.9	20	20
048	575-3-60	5.6	44.0	0.6	1.6	2NH04501058	1	10.0 ***	9.6	14.0	15	15
						2NH04501558	1	15.0 ***	14.4	20.0	25	25
						2NH04502058	2	20.0 ***	19.2	26.1	30	30
						2NH04502558	2	25.0 ***	24.1	32.1	35	35
060	575-3-60	6.4	50.0	0.6	2.8	2NH04501058	1	10.0 ***	9.6	15.5	20	20
						2NH04501558	1	15.0 ***	14.4	21.5	25	25
						2NH04502058	2	20.0 ***	19.2	27.6	30	30
						2NH04502558	2	25.0 ***	24.1	33.6	35	35

¹ = Dual element, time delay type.

² = Standard circuit breakers may be used in Canada and on

applications over 60 amps where the heaters are separately fused.

* = KW listed is for 240 volts, use this table for 208 or 230 volts.

** = KW listed is for 480 volts, use this table for 460 volts.

*** = KW listed is for 600 volts, use this table for 575 volts.

ELECTRIC HEAT CORRECTION FACTORS	NOMINAL VOLTAGE	VOLTAGE	KW CAP. MULTIPLIER
	240	208	.75
		230	.92
	480	460	.92
600		575	.92

TABLE 2 - ELECTRICAL DATA (10 SEER HEAT PUMP / ELECTRIC HEAT)

MODEL BHABUA	POWER SUPPLY	COMPRESSOR		OUTDOOR FAN MOTOR FLA	SUPPLY AIR BLOWER MOTOR, FLA	ELECTRIC HEAT ACCESSORY				MINIMUM CIRCUIT AMPACITY	MAX. FUSE SIZE, ¹ AMPS	MAX. HACR ² BREAKER SIZE
		RLA	LRA			MODEL NO.	STAGE	KW	TOTAL AMPS			
018	208/230-1-60	9.0	48.0	1.1	2.6	2NH04500506	1	3.8/5.0 *	18.1/20.8	37.5/41.0	40/45	40/45
						2NH04500706	2	5.6/7.5 *	27.1/31.3	48.8/54.0	50/60	50/60
024	208/230-1-60	11.2	60.0	1.1	2.6	2NH04500506	1	3.8/5.0 *	18.1/20.8	40.7/44.2	45/50	45/50
						2NH04500706	2	5.6/7.5 *	27.1/31.3	52.0/57.2	60/60	60/60
						2NH04501006	2	7.5/10.0 *	36.1/41.7	63.3/70.2	70/80	70/80
030	208/230-1-60	14.7	73.0	1.1	2.6	2NH04500506	1	3.8/5.0 *	18.1/20.8	44.7/48.2	50/50	50/50
						2NH04500706	2	5.6/7.5 *	27.3/31.3	56.0/61.2	60/70	60/70
						2NH04501006	2	7.5/10.0 *	36.1/41.7	67.3/74.2	70/80	70/80
						2NH04501506	2	11.3/15.0 *	54.2/62.5	89.8/100.3	90/110	90/110
						2ND04501506	2	3.8/5.0	18.1/20.8	44.7/48.2	50/50	50/50
036	208/230-1-60	17.3	94.0	1.1	3.5	2NH04500506	1	3.8/5.0 *	18.1/20.8	48.8/52.3	60/60	60/60
						2NH04500706	2	5.6/7.5 *	27.1/31.3	60.1/65.3	70/70	70/70
						2NH04501006	2	7.5/10.0 *	36.1/41.7	71.4/78.3	80/80	80/80
						2NH04501506	2	11.3/15.0 *	54.2/62.5	93.9/104.4	100/110	100/110
						2ND04501506	2	3.8/5.0	18.1/20.8	48.8/52.3	60/60	60/60
						2ND04501506	2	7.5/10.0	36.1/41.7	45.1/52.1	50/60	50/60
042	208/230-1-60	20.5	120.0	1.1	3.5	2NH04501006	2	7.5/10.0 *	36.1/41.7	75.4/82.3	80/90	80/90
						2NH04501506	2	11.3/15.0 *	54.2/62.5	97.9/108.4	100/110	100/110
						2ND04501506	2	3.8/5.0	18.1/20.8	52.8/56.3	60/70	60/70
						2ND04501506	2	7.5/10.0	36.1/41.7	45.1/52.1	50/60	50/60
048	208/230-1-60	24.4	140.0	1.5	4.0	2NP04501006	2	7.5/10.0 *	36.1/41.7	81.1/88.1	90/100	90/100
						2NP04501506	2	11.3/15.0 *	54.2/62.5	103.7/114.1	110/125	110/125
						2NP04502006	2	15.0/20.0 *	72.2/83.3	126.3/140.2	150/150	150/150
						2NX04502506	2	18.8/25.0 *	90.3/104.2	148.8/166.2	150/175	150/175
060	208/230-1-60	28.9	165.0	1.5	7.0	2NH04501006	2	7.5/10.0 *	36.1/41.7	89.8/96.7	100/110	100/110
						2NH04501506	2	11.3/15.0 *	54.2/62.5	112.3/122.8	125/125	125/125
						2NH04502006	2	15.0/20.0 *	72.2/83.3	134.9/148.8	150/150	150/150
						2NH04502506	2	18.8/25.0 *	90.3/104.2	157.5/174.8	175/175	175/175
036	208/230-3-60	10.9	78.0	1.1	3.5	2NH04501025	1	7.5/10.0 *	20.8/24.1	44.3/48.3	45/50	45/50
						2NH04501525	1	11.3/15.0 *	31.3/36.1	57.3/63.3	60/70	60/70
042	208/230-3-60	14.1	110.0	1.1	3.5	2NH04501025	1	7.5/10.0 *	20.8/24.1	48.3/57.3	50/60	50/60
						2NH04501525	1	11.3/15.0 *	31.3/36.1	61.3/67.3	70/70	70/70
048	208/230-3-60	14.1	105.0	1.5	4.0	2NP04501025	1	7.5/10.0 *	20.8/24.1	49.2/53.2	50/60	50/60
						2NP04501525	1	11.3/15.0 *	31.3/36.1	62.2/68.2	70/70	70/70
						2NP04502025	2	15.0/20.0 *	41.7/48.1	75.3/83.3	80/90	80/90
						2NH04502525	2	18.8/25.0 *	52.1/60.1	88.3/98.3	90/100	90/100
060	208/230-3-60	16.0	125.0	1.5	7.0	2NH04501025	1	7.5/10.0 *	20.8/24.1	54.6/58.6	60/60	60/60
						2NH04501525	1	11.3/15.0 *	31.3/36.1	67.6/73.6	70/80	70/80
						2NH04502025	2	15.0/20.0 *	41.7/48.1	80.7/88.7	90/90	90/90
						2NH04502525	2	18.8/25.0 *	52.1/60.1	93.7/103.7	100/110	100/110
036	460-3-60	5.8	40.0	0.6	1.8	2NH04501046	1	10.0 **	12.8	24.6	25	25
						2NH04501546	1	15.0 **	18.0	32.2	35	35
042	460-3-60	7.1	54.0	0.6	1.8	2NH04501046	1	10.0 **	12.0	26.2	30	30
						2NH04501546	1	15.0 **	18.0	33.8	35	35
048	460-3-60	7.1	55.0	0.8	2.0	2NP04501046	1	10.0 **	12.0	26.7	30	30
						2NH04501546	1	15.0 **	18.0	34.2	35	35
						2NH04502046	2	20.0 **	24.1	41.7	45	45
						2NH04502546	2	25.0 **	30.1	49.3	50	50
060	460-3-60	8.0	67.0	0.8	3.5	2NH04501046	1	10.0 **	12.0	29.4	30	30
						2NH04501546	1	15.0 **	18.0	36.9	40	40
						2NP04502046	2	20.0 **	24.1	44.4	45	45
						2NP04502546	2	25.0 **	30.1	51.9	60	60

² = Standard circuit breakers may be used in Canada and on applications over 60 amps where the heaters are separately fused.

* = KW listed is for 240 volts, use this table for 208 or 230 volts.

** = KW listed is for 480 volts, use this table for 460 volts.

*** = KW listed is for 600 volts, use this table for 575 volts.

ELECTRIC HEAT CORRECTION FACTORS	NOMINAL VOLTAGE	VOLTAGE	KW CAP. MULTIPLIER
	240	208	.75
	480	230	.92
	600	460	.92
	600	575	.92

**TABLE 2 - ELECTRICAL DATA (10 SEER HEAT PUMP / ELECTRIC HEAT)
(CONTINUED)**

MODEL	BHA/BUA	POWER SUPPLY	COMPRES-SOR		OUTDOOR FAN MOTOR FLA	SUPPLY AIR BLOWER MOTOR, FLA	ELECTRIC HEAT ACCESSORY				MINIMUM CIRCUIT AMPAC-ITY	MAX. FUSE SIZE, ¹ AMPS	MAX. HACR ² BREAKER SIZE
			RLA	LRA			MODEL NO.	STAGE	KW	TOTAL AMPS			
036	575-3-60	4.5	32.0	0.4	1.5	2NH04501058	1	10.0 ***	9.6	19.6	20	20	
						2NH04501558	1	15.0 ***	14.4	25.6	30	30	
042	575-3-60	5.8	44.0	0.4	1.5	2NH04501058	1	10.0 ***	9.6	21.1	25	25	
						2NH04501558	1	15.0 ***	14.4	27.2	30	30	
048	575-3-60	5.6	44.0	0.6	1.6	2NH04501058	1	10.0 ***	9.6	21.3	25	25	
						2NH04501558	1	15.0 ***	14.4	27.3	30	30	
						2NH04502058	2	20.0 ***	19.2	33.3	35	35	
						2NH04502558	2	25.0 ***	24.1	39.3	40	40	
060	575-3-60	6.4	50.0	0.6	2.8	2NH04501058	1	10.0 ***	9.6	23.4	25	25	
						2NH04501558	1	15.0 ***	14.4	29.5	30	30	
						2NP04502058	2	20.0 ***	19.2	35.5	40	40	
						2NP04502558	2	25.0 ***	24.1	41.5	45	45	

¹ = Dual element, time delay type.

² = Standard circuit breakers may be used in Canada and on applications over 60 amps where the heaters are separately fused.

* = KW listed is for 240 volts, use this table for 208 or 230 volts.

** = KW listed is for 480 volts, use this table for 460 volts.

*** = KW listed is for 600 volts, use this table for 575 volts.

ELECTRIC HEAT CORRECTION FACTORS	NOMINAL VOLTAGE	VOLTAGE	KW CAP. MULTI-PLIER
	240	208	.75
	480	230	.92
	600	460	.92
		575	.92

TABLE 3 - ELECTRICAL DATA (12 SEER COOLING / ELECTRIC HEAT)

MODEL DEH/DPH	POWER SUPPLY	COMPRESSOR		COND. FAN MOTOR FLA	SUPPLY AIR BLOWER MOTOR, FLA	ELECTRIC HEAT ACCESSORY			MINIMUM CIRCUIT AMPACITY	MAX. FUSE SIZE, ¹ AMPS	MAX. HACR ² BREAKER SIZE	
		RLA	LRA			MODEL NO.	STAGE	KW				TOTAL AMPS
018	208/230-1-60	9.0	48.0	1.1	2.6	2NH04500506	1	3.8/5.0 *	18.1/20.8	25.8/29.3	30/30	30/30
						2NH04500706	2	5.6/7.5 *	27.1/31.3	37.1/42.3	40/45	40/45
024	208/230-1-60	11.2	60.0	1.1	2.6	2NH04500506	1	3.8/5.0 *	18.1/20.8	25.8/29.3	30/30	30/30
						2NH04500706	2	5.6/7.5 *	27.1/31.3	37.1/42.3	40/45	40/45
						2NH04501006	2	7.5/10.0 *	36.1/41.7	48.4/55.3	50/60	50/60
030	208/230-1-60	12.0	73.0	1.1	2.6	2NH04500506	1	3.8/5.0 *	18.1/20.8	25.8/29.3	30/30	30/30
						2NH04500706	2	5.6/7.5 *	27.3/31.3	37.1/42.3	40/45	40/45
						2NH04501006	2	7.5/10.0 *	36.1/41.7	48.4/55.3	50/60	50/60
						2NH04501506	2	11.3/15.0 *	54.2/62.5	71.0/81.4	80/90	80/90
036	208/230-1-60	17.3	94.0	1.1	3.5	2NH04500506	1	3.8/5.0 *	18.1/20.8	26.9/30.4	35/40	35/40
						2NH04500706	2	5.6/7.5 *	27.1/31.3	38.2/43.4	40/45	40/45
						2NH04501006	2	7.5/10.0 *	36.1/41.7	49.5/56.5	50/60	50/60
						2NH04501506	2	11.3/15.0 *	54.2/62.5	72.1/82.5	80/90	80/90
042	208/230-1-60	20.5	120.0	1.1	3.5	2NH04500506	1	3.8/5.0 *	18.1/20.8	30.2/30.4	40/40	40/40
						2NH04500706	2	5.6/7.5 *	27.1/31.3	38.2/43.4	50/50	50/50
						2NH04501006	2	7.5/10.0 *	36.1/41.7	49.5/56.5	50/60	50/60
						2NH04501506	2	11.3/15.0 *	54.2/62.5	72.1/82.5	80/90	80/90
030	208/230-3-60	10.0	63.0	1.1	2.6	2NH04501025	1	7.5/10.0 *	20.8/24.1	29.3/33.3	30/35	30/35
						2NH04501525	1	11.3/15.0 *	31.3/36.1	42.3/48.4	45/50	45/50
036	208/230-3-60	10.9	78.0	1.1	3.5	2NH04501025	1	7.5/10.0 *	20.8/24.1	30.4/34.4	35/35	35/35
						2NH04501525	1	11.3/15.0 *	31.3/36.1	43.5/49.5	45/50	45/50
042	208/230-3-60	14.1	110.0	1.1	3.5	2NH04501025	1	7.5/10.0 *	20.8/24.1	30.4/34.4	35/35	35/35
						2NH04501525	1	11.3/15.0 *	31.3/36.1	43.5/49.5	45/50	45/50
030	460-3-60	5.0	31.0	0.6	1.4	2NH04501046	1	10.0 **	12.0	16.8	20	20
						2NH04501546	1	15.0 **	18.0	24.3	25	25
036	460-3-60	5.8	40.0	0.6	1.8	2NH04501046	1	10.0 **	12.0	17.3	20	20
						2NH04501546	1	15.0 **	18.0	24.8	25	25
042	460-3-60	7.1	54.0	0.6	1.8	2NH04501046	1	10.0 **	12.0	17.3	20	20
						2NH04501546	1	15.0 **	18.0	24.8	25	25
036	575-3-60	4.5	32.0	0.4	1.5	2NH04501058	1	10.0 ***	9.6	13.9	15	15
						2NH04501558	1	15.0 ***	14.4	19.9	20	20
042	575-3-60	5.8	44.0	0.4	1.5	2NH04501058	1	10.0 ***	9.6	13.9	15	15
						2NH04501558	1	15.0 ***	14.4	19.9	20	20
048	575-3-60	5.8	36.0	0.6	2.0	2NH04501058	1	10.0 ***	9.6	14.5	15	15
						2NH04501558	1	15.0 ***	14.4	20.5	25	25
						2NH04502058	2	20.0 ***	19.2	26.6	30	30
						2NH04502558	2	25.0 ***	24.1	32.6	35	35
060	575-3-60	6.4	40.0	0.6	2.8	2NH04501058	1	10.0 ***	9.6	15.5	20	20
						2NH04501558	1	15.0 ***	14.4	21.5	25	25
						2NH04502058	2	20.0 ***	19.2	27.6	30	30
						2NH04502558	2	25.0 ***	24.1	33.6	35	35

¹ = Dual element, time delay type.

² = Standard circuit breakers may be used in Canada and on applications over 60 amps where the heaters are separately fused.

* = KW listed is for 240 volts, use this table for 208 or 230 volts.

** = KW listed is for 480 volts, use this table for 460 volts.

*** = KW listed is for 600 volts, use this table for 575 volts.

ELECTRIC HEAT CORRECTION FACTORS	NOMINAL VOLTAGE	VOLTAGE	KW CAP. MULTIPLIER
	240	208	.75
		230	.92
	480	460	.92
600		575	.92

TABLE 4 - ELECTRICAL DATA (12 SEER HEAT PUMP / ELECTRIC HEAT)

MODEL BHH/BUH	POWER SUPPLY	COMPRESSOR		COND. FAN MOTOR FLA	SUPPLY AIR BLOWER MOTOR, FLA	ELECTRIC HEAT ACCESSORY			MINIMUM CIRCUIT AMPACITY	MAX. FUSE SIZE, ¹ AMPS	MAX. HACR ² BREAKER SIZE
		RLA	LRA			MODEL NO.	KW	TOTAL AMPS			
018	208/230-1-60	7.1	48.0	1.1	2.6	2NH04500506	3.8 / 5.0 *	18.1 / 20.8	35.1 / 38.6	40 / 40	40 / 40
						2NH04500706	5.6 / 7.5 *	27.1 / 31.3	46.4 / 51.6	50 / 60	50 / 60
024	208/230-1-60	9.3	57.0	1.1	2.6	2NH04500506	3.8 / 5.0 *	18.1 / 20.8	37.9 / 41.4	40 / 45	40 / 45
						2NH04500706	5.6 / 7.5 *	27.1 / 31.3	49.2 / 54.4	50 / 60	50 / 60
						2NH04501006	7.5 / 10.0 *	36.1 / 41.7	60.5 / 67.4	70 / 70	70 / 70
030	208/230-1-60	15.0	72.5	1.1	2.6	2NH04500506	3.8 / 5.0 *	18.1 / 20.8	45.0 / 48.5	50 / 50	50 / 50
						2NH04500706	5.6 / 7.5 *	27.3 / 31.3	56.3 / 61.5	60 / 70	60 / 70
						2NH04501006	7.5 / 10.0 *	36.1 / 41.7	67.6 / 74.5	70 / 80	70 / 80
						2NH04501506	11.3 / 15.0 *	54.2 / 62.5	90.2 / 100.6	100 / 110	100 / 110
		0.0	0.0	0.0	0.0	2ND04501506	3.8/5.0	18.1/20.8	45.0/48.5	50/50	50/50
		0.0	0.0	0.0	0.0	7.5/10.0	36.1/41.7	45.1/52.1	50/60	50/60	
036	208/230-1-60	17.2	94.0	1.1	3.5	2NH04500506	3.8 / 5.0 *	18.1 / 20.8	48.7 / 52.1	60 / 60	60 / 60
						2NH04500706	5.6 / 7.5 *	27.1 / 31.3	60.0 / 65.2	70 / 70	70 / 70
						2NH04501006	7.5 / 10.0 *	36.1 / 41.7	71.2 / 78.2	80 / 80	80 / 80
						2NH04501506	11.3 / 15.0 *	54.2 / 62.5	93.8 / 104.2	100 / 110	100 / 110
		0.0	0.0	0.0	0.0	2ND04501506	3.8/5.0	18.1/20.8	48.7/52.1	60/60	60/60
		0.0	0.0	0.0	0.0	7.5/10.0	36.1/41.7	45.1/52.1	50/60	50/60	
042	208/230-1-60	20.0	104.0	1.1	3.5	2NP04501006	7.5 / 10.0 *	36.1 / 41.7	74.7 / 81.7	80 / 90	80 / 90
						2NP04501506	11.3 / 15.0 *	54.2 / 62.5	97.3 / 107.7	100 / 110	100 / 110
		0.0	0.0	0.0	0.0	2ND04501506	3.8/5.0	18.1/20.8	52.2/55.6	60/70	60/70
				0.0	0.0	0.0	0.0	7.5/10.0	36.1/41.7	45.1/52.1	50/60
048	208/230-1-60	23.4	126.0	1.5	4.0	2NP04501006	7.5 / 10.0 *	36.1 / 41.7	79.9/86.8	90/90	90/90
						2NP04501506	11.3 / 15.0 *	54.2 / 62.5	110.8/121.9	110/125	110/125
						2NP04502006	15.0 / 20.0 *	72.2 / 83.3	125.0/138.9	150/150	150/150
						2NX04502506	18.8 / 25.0 *	90.3 / 104.2	147.6/165.0	150/175	150/175
						2NP04501006	7.5 / 10.0 *	36.1 / 41.7	88.2/95.2	100/110	100/110
2NP04501506	11.3 / 15.0 *	54.2 / 62.5	110.8/121.2	125/125	125/125						
2NH04502006	15.0 / 20.0 *	72.2 / 83.3	133.4/147.3	150/150	150/150						
2NP04502506	18.8 / 25.0 *	90.3 / 104.2	155.9/173.3	175/175	175/175						
030	208/230-3-60	10.0	63.0	1.1	3.5	2NH04501025	7.5 / 10.0 *	20.8 / 24.1	42.3/46.3	45/50	45/50
						2NH04501525	11.3 / 15.0 *	31.3 / 36.1	55.3/61.3	60/70	60/70
036	208/230-3-60	11.4	78.0	1.1	3.5	2NH04501025	7.5 / 10.0 *	20.8 / 24.1	44.9 / 48.9	50/50	50/50
						2NH04501525	11.3 / 15.0 *	31.3 / 36.1	57.9 / 64.0	60/70	60/70
042	208/230-3-60	13.9	88.0	1.1	3.5	2NP04501025	7.5 / 10.0 *	20.8 / 24.1	48.0 / 52.0	50/60	50/60
						2NP04501525	11.3 / 15.0 *	31.3 / 36.1	61.1 / 67.1	70/70	70/70
048	208/230-3-60	13.0	93.0	1.5	4.0	2NP04501025	7.5 / 10.0 *	20.8 / 24.1	47.8/51.8	50/60	50/60
						2NP04501525	11.3 / 15.0 *	31.3 / 36.1	60.8/66.9	70/70	70/70
						2NP04502025	15.0 / 20.0 *	41.7 / 48.1	73.9/81.9	80/90	80/90
						2NH04502525	18.8 / 25.0 *	52.1 / 60.1	86.9/96.9	90/100	90/100
						2NH04501025	7.5 / 10.0 *	20.8 / 24.1	54.8/58.8	60/70	60/70
2NH04501525	11.3 / 15.0 *	31.3 / 36.1	67.8/73.8	70/80	70/80						
2NH04502025	15.0 / 20.0 *	41.7 / 48.1	80.8/88.8	90/90	90/90						
2NH04502525	18.8 / 25.0 *	52.1 / 60.1	93.9/103.9	100/110	100/110						
030	460-3-60	5.0	31.0	0.6	1.8	2NH04501046	10.0**	12.0	23.3	25	25
						2NH04501546	15.0**	18.0	30.8	35	35
036	460-3-60	5.7	40.0	0.6	1.8	2NH04501046	10.0**	12.0	24.5	25	25
						2NH04501546	15.0**	18.0	32.0	35	35
042	460-3-60	6.4	44.0	0.6	1.8	2NH04501046	10.0**	12.0	25.4	30	30
						2NH04501546	15.0**	18.0	33.0	35	35
048	460-3-60	6.4	46.5	0.8	2.0	2NP04501046	10.0**	12.0	25.8	30	30
						2NH04501546	15.0**	18.0	33.4	35	35
						2NH04502046	20.0**	24.1	40.9	45	45
						2NH04502546	25.0**	30.1	48.4	50	50
060	460-3-60	8.2	62.0	0.8	5.6	2NP04501046	10.0**	12.0	28.9	30	30
						2NH04501546	15.0**	18.0	36.4	40	40
						2NH04502046	20.0**	24.1	43.9	45	45
						2NP04502546	25.0**	30.1	51.4	60	60
								25.0**	30.1	51.4	60

¹ = Dual element, time delay type.² = Standard circuit breakers may be used in Canada and on applications over 60 amps where the heaters are separately fused.

* = KW listed is for 240 volts, use table on previous page for 208 or 230 volts.

** = KW listed is for 480 volts, use table on previous page for 460 volts.

*** = KW listed is for 600 volts, use table on previous page for 575 volts.

**TABLE 4 - ELECTRICAL DATA (12 SEER HEAT PUMP / ELECTRIC HEAT)
(CONTINUED)**

MODEL BHH/BUH	POWER SUPPLY	COMPRESSOR		COND. FAN MOTOR FLA	SUPPLY AIR BLOWER MOTOR, FLA	ELECTRIC HEAT ACCESSORY			MINIMUM CIRCUIT AMPACITY	MAX. FUSE SIZE, ¹ AMPS	MAX. HACR ² BREAKER SIZE
		RLA	LRA			MODEL NO.	KW	TOTAL AMPS			
036	575-3-60	4.7	32.0	0.4	1.5	2NH04501058	10.0***	9.6	19.8	20	20
						2NH04501558	15.0***	14.4	25.8	30	20
042	575-3-60	5.4	34.0	0.4	1.5	2NH04501058	10.0***	9.6	20.7	25	25
						2NH04501558	15.0***	14.4	26.7	30	30
048	575-3-60	5.1	37.2	0.6	1.6	2NH04501058	10.0***	9.6	20.6	25	25
						2NH04501558	15.0***	14.4	26.7	30	30
						2NH04502058	20.0***	19.2	32.7	35	35
						2NH04502558	25.0***	24.1	38.7	40	40
060	575-3-60	7.0	50.0	0.6	2.8	2NH04501058	10.0***	9.6	24.2	25	25
						2NH04501558	15.0***	14.4	30.2	35	35
						2NP04502058	20.0***	19.2	36.3	40	40
						2NP04502558	25.0***	24.1	42.3	45	45

¹ = Dual element, time delay type.
² = Standard circuit breakers may be used in Canada and on applications over 60 amps where the heaters are separately fused.

* = KW listed is for 240 volts, use table on previous page for 208 or 230 volts.
 ** = KW listed is for 480 volts, use table on previous page for 460 volts.
 *** = KW listed is for 600 volts, use table on previous page for 575 volts.

TABLE 5 - ELECTRICAL DATA (13 SEER COOLING / ELECTRIC HEAT)

MODELS DEM/DPH/DPM	POWER SUPPLY	COMPRESSOR		COND. FAN MOTOR FLA	SUPPLY AIR BLOWER MOTOR, FLA	ELECTRIC HEAT ACCESSORY				MINIMUM CIRCUIT AMPACITY	MAX. FUSE SIZE, ¹ AMPS	MAX. HACR ² BREAKER SIZE
		RLA	LRA			MODEL NO.	STAGE	KW	TOTAL AMPS			
024	208/230-1-60	10	55	1.1	4.3	2NH04500506	1	3.8 / 5.0 *	18.1 / 20.8	28.2 / 31.4	30 / 35	30 / 35
						2NH04500706	2	5.6 / 7.5 *	27.1 / 31.3	39.0 / 44.4	40 / 45	40 / 45
						2NH04501006	2	7.5 / 10.0 *	36.1 / 41.7	50.4 / 57.5	60 / 60	60 / 60
030	208/230-1-60	11	68	1.1	4.3	2NH04500506	1	3.8 / 5.0 *	18.3 / 20.8	28.2 / 31.4	30 / 35	30 / 35
						2NH04500706	2	5.6 / 7.5 *	26.9 / 31.3	39.0 / 44.4	40 / 45	40 / 45
						2NH04501006	2	7.5 / 10.0 *	36.1 / 41.7	50.4 / 47.4	60 / 60	60 / 60
						2NH04501506	2	11.3 / 15.0 *	54.2 / 62.5	73.3 / 83.5	80 / 80	80 / 90
036	208/230-1-60	17.2	94.0	1.1	7.3	2NH04500506	1	3.8 / 5.0 *	18.1 / 20.8	27.7 / 31.2	30 / 35	30 / 35
						2NH04500706	2	5.6 / 7.5 *	27.1 / 31.3	39.0 / 44.2	40 / 45	40 / 45
						2NH04501006	2	7.5 / 10.0 *	36.1 / 41.7	50.3 / 47.3	60 / 60	60 / 60
						2NH04501506	2	11.3 / 15.0 *	54.2 / 62.5	72.9 / 83.3	80 / 90	80 / 90
042	208/230-1-60	21.1	115	1.6	6.8	2NH04500506	1	3.8 / 5.0 *	18.1 / 20.8	34.8 / 34.8	45 / 45	45 / 45
						2NH04500706	2	5.6 / 7.5 *	27.1 / 31.3	42.4 / 47.6	50 / 50	50 / 50
						2NH04501006	2	7.5 / 10.0 *	36.1 / 41.7	53.6 / 60.6	60 / 70	60 / 70
						2NH04501506	2	11.3 / 15.0 *	54.2 / 62.5	76.2 / 86.6	80 / 90	80 / 90
048	208/230-1-60	20.5	115	1.3	7.3	2NH04501006	2	7.5 / 10.0 *	36.1 / 41.7	54.3 / 61.2	60 / 70	60 / 70
						2NH04501506	2	11.3 / 15.0 *	54.2 / 62.5	76.8 / 87.3	80 / 90	80 / 90
						2NH04502006	2	15.0 / 20.0 *	72.2 / 83.3	99.4 / 113.3	100 / 125	100 / 125
						2NH04502506	2	18.8 / 25.0 *	90.3 / 104.2	122.0 / 139.3	125 / 150	125 / 150
060	208/230-1-60	28.8	169	1.3	9.4	2NH04501006	2	7.5 / 10.0 *	36.1 / 41.7	56.9 / 63.8	70 / 70	70 / 70
						2NH04501506	2	11.3 / 15.0 *	54.2 / 62.5	79.5 / 89.9	80 / 90	80 / 90
						2NH04502006	2	15.0 / 20.0 *	72.2 / 83.3	102.0 / 115.9	110 / 125	110 / 125
						2NH04502506	2	18.8 / 25.0 *	90.3 / 104.2	124.6 / 142.0	125 / 150	125 / 150
042	208/230/3-60	13.4	89	1.6	6.8	2NH04501025	1	7.5 / 10.0 *	20.8 / 24.1	34.6 / 38.6	35 / 40	35 / 40
						2NH04501525	1	11.3 / 15.0 *	31.3 / 36.1	47.6 / 53.6	50 / 60	50 / 60
048	208/230-3-60	14.1	90	1.3	7.3	2NH04501025	1	7.5 / 10.0 *	20.8 / 24.1	35.2 / 39.2	40 / 40	40 / 40
						2NH04501525	1	11.3 / 15.0 *	31.3 / 36.1	48.2 / 54.2	50 / 60	50 / 60
						2NH04502025	2	15.0 / 20.0 *	41.7 / 48.1	61.2 / 69.3	70 / 70	70 / 70
						2NH04502525	2	18.8 / 25.0 *	52.1 / 60.1	74.3 / 84.3	80 / 90	80 / 90
060	208/230-3-60	19.3	123	1.3	9.4	2NH04501025	1	7.5 / 10.0 *	20.8 / 24.1	37.8 / 41.8	50 / 50	50 / 50
						2NH04501525	1	11.3 / 15.0 *	31.3 / 36.1	50.8 / 56.9	60 / 60	60 / 60
						2NH04502025	2	15.0 / 20.0 *	41.7 / 48.1	63.9 / 71.9	70 / 80	70 / 80
						2NH04502525	2	18.8 / 25.0 *	52.1 / 60.1	76.9 / 86.9	80 / 90	80 / 90
042	460-3-60	6.4	45	0.75	6.8	2NH04501046	1	10.0 **	12.0	23.5	25	25
						2NH04501546	1	15.0 **	18.0	31.1	35	35
048	460-3-60	7.1	45	0.7	7.3	2NH04501046	1	10.0 **	12.0	19.6	20	20
						2NH04501546	1	15.0 **	18.0	27.1	30	30
						2NH04502046	2	20.0 **	24.1	34.6	35	35
						2NH04502546	2	25.0 **	30.1	42.2	45	45
060	460-3-60	7.5	49.5	0.7	9.4	2NH04501046	1	10.0 **	12.0	20.9	25	25
						2NH04501546	1	15.0 **	18.0	28.4	30	30
						2NH04502046	2	20.0 **	24.1	35.9	40	40
						2NH04502546	2	25.0 **	30.1	43.5	45	45
042	575-3-60	6.4	38	0.6	6.8	2NH04501058	1	10.0 ***	9.6	20.5	25	25
						2NH04501558	1	15.0 ***	14.4	26.5	30	30

¹ = Dual element, time delay type.² = Standard circuit breakers may be used in Canada and on applications over 60 amps where the heaters are separately fused.

* = KW listed is for 240 volts, use this table for 208 or 230 volts.

** = KW listed is for 480 volts, use this table for 460 volts.

*** = KW listed is for 600 volts, use this table for 575 volts.

ELECTRIC HEAT CORRECTION FACTORS	NOMINAL VOLTAGE	VOLTAGE	KW CAP. MULTI- PLIER
	240	208	.75
		230	.92
	480	460	.92
575		.92	

TABLE 6 - ELECTRICAL DATA (13 SEER HEAT PUMP / ELECTRIC HEAT)

MODEL BHP/BUP	POWER SUPPLY	COMPRESSOR		COND. FAN MOTOR FLA	SUPPLY AIR BLOWER MOTOR, FLA	ELECTRIC HEAT ACCESSORY			MINIMUM CIRCUIT AMPACITY	MAX. FUSE SIZE, ¹ AMPS	MAX. HACR ² BREAKER SIZE
		RLA	LRA			MODEL NO.	KW	TOTAL AMPS			
024	208/230-1-60	9.3	57.0	1.1	5.0	2NH04500506	3.8 / 5.0 *	18.1 / 20.8	40.3 / 43.8	45 / 45	45 / 45
						2NH04500706	5.6 / 7.5 *	27.1 / 31.3	51.6 / 56.8	60 / 60	60 / 60
						2NH04501006	7.5 / 10.0 *	36.1 / 41.7	62.9 / 69.8	70 / 70	70 / 70
030	208/230-1-60	15.0	72.5	1.1	5.0	2NH04500506	3.8 / 5.0 *	18.1 / 20.8	47.4 / 50.9	50 / 60	50 / 60
						2NH04500706	5.6 / 7.5 *	27.3 / 31.3	58.7 / 63.9	60 / 70	60 / 70
						2NH04501006	7.5 / 10.0 *	36.1 / 41.7	70.0 / 76.9	70 / 80	70 / 80
						2NH04501506	11.3 / 15.0 *	54.2 / 62.5	92.6 / 103.0	100 / 110	100 / 110
036	208/230-1-60	17.2	94.0	1.1	7.3	2NH04500506	3.8 / 5.0 *	18.1 / 20.8	52.5 / 55.9	60 / 60	60 / 60
						2NH04500706	5.6 / 7.5 *	27.1 / 31.3	63.8 / 69.0	70 / 70	70 / 70
						2NH04501006	7.5 / 10.0 *	36.1 / 41.7	75.0 / 82.0	80 / 90	80 / 90
						2NH04501506	11.3 / 15.0 *	54.2 / 62.5	97.6 / 108.0	100 / 110	100 / 110
042	208/230-1-60	20.0	104.0	1.1	7.3	2NP04501006	7.5 / 10.0 *	36.1 / 41.7	78.5 / 85.5	80 / 90	80 / 90
						2NP04501506	11.3 / 15.0 *	54.2 / 62.5	101.1 / 111.5	100 / 125	100 / 125
048	208/230-1-60	23.4	126.0	1.5	7.3	2NP04501006	7.5 / 10.0 *	36.1 / 41.7	83.2 / 90.1	90 / 100	90 / 100
						2NP04501506	11.3 / 15.0 *	54.2 / 62.5	105.8 / 116.2	110 / 125	110 / 125
						2NP04502006	15.0 / 20.0 *	72.2 / 83.3	128.3 / 142.2	150 / 150	150 / 150
						2NP04502506	18.8 / 25.0 *	90.3 / 104.2	150.9 / 168.3	175 / 175	175 / 175
060	208/230-1-60	25	150	2.3	9.1	2NP04501006	7.5 / 10.0 *	36.1 / 41.7	87.7 / 94.7	100 / 100	100 / 100
						2NP04501506	11.3 / 15.0 *	54.2 / 62.5	110.6 / 120.8	125 / 125	125 / 125
						2NP04502006	15.0 / 20.0 *	72.2 / 83.3	132.8 / 146.8	150 / 150	150 / 150
						2NP04502506	18.8 / 25.0 *	90.3 / 104.2	155.6 / 172.9	175 / 175	175 / 175
030	208/230-3-60	10.0	63.0	1.1	5.0	2NH04501025	7.5 / 10.0 *	20.8 / 24.1	44.7 / 48.7	45 / 50	45 / 50
						2NH04501525	11.3 / 15.0 *	31.3 / 36.1	57.7 / 63.7	60 / 70	60 / 70
036	208/230-3-60	11.4	78.0	1.1	7.3	2NH04501025	7.5 / 10.0 *	20.8 / 24.1	48.7 / 52.7	50 / 60	50 / 60
						2NH04501525	11.3 / 15.0 *	31.3 / 36.1	61.7 / 67.8	70 / 80	70 / 80
042	208/230-3-60	13.9	88.0	1.1	7.3	2NP04501025	7.5 / 10.0 *	20.8 / 24.1	51.8 / 55.8	60 / 60	60 / 60
						2NP04501525	11.3 / 15.0 *	31.3 / 36.1	64.9 / 70.9	70 / 70	70 / 70
048	208/230-3-60	13.0	93.0	1.5	7.3	2NP04501025	7.5 / 10.0 *	20.8 / 24.1	51.1 / 55.1	60 / 60	60 / 60
						2NP04501525	11.3 / 15.0 *	31.3 / 36.1	64.1 / 70.2	70 / 80	70 / 80
						2NP04502025	15.0 / 20.0 *	41.7 / 48.1	77.2 / 85.2	80 / 90	80 / 90
						2NP04502525	18.8 / 25.0 *	52.1 / 60.1	90.2 / 100.2	100 / 110	100 / 110
060	208/230-3-60	17.3	130	2.3	9.1	2NP04501025	7.5 / 10.0 *	20.8 / 24.1	59.1 / 63.1	70 / 70	70 / 70
						2NP04501525	11.3 / 15.0 *	31.3 / 36.1	72.2 / 78.1	80 / 80	80 / 80
						2NP04502025	15.0 / 20.0 *	41.7 / 48.1	85.1 / 93.2	90 / 100	90 / 100
						2NP04502525	18.8 / 25.0 *	52.1 / 60.1	98.3 / 108.2	100 / 110	100 / 110
030	460-3-60	5.0	31.0	0.6	5.0	2NH04501046	10.0**	12.0	27.5	30	30
						2NH04501546	15.0**	18.0	35.4	40	40
036	460-3-60	5.7	40.0	0.6	7.3	2NH04501046	10.0**	12.0	30.7	35	35
						2NH04501546	15.0**	18.0	38.6	40	40
042	460-3-60	6.4	44.0	0.6	7.3	2NP04501046	10.0**	12.0	31.6	35	35
						2NP04501546	15.0**	18.0	29.4	40	40
048	460-3-60	6.4	46.5	0.8	7.3	2NP04501046	10.0**	12.0	31.8	35	35
						2NP04501546	15.0**	18.0	39.6	40	40
						2NP04502046	20.0**	24.1	47.5	50	50
						2NP04502546	25.0**	30.1	55.3	60	60
060	460-3-60	8.4	70	1.3	9.1	2NP04501046	10.0**	12.0	36.1	40	40
						2NP04501546	15.0**	18.0	43.6	45	45
						2NP04502046	20.0**	24.1	51.1	60	60
						2NP04502546	25.0**	30.1	58.7	60	60
060	575-3-60	7.1	53	1.3	9.5	2NP04501058	10.0***	10.0	32.3	35	35
						2NP04501558	15.0***	15.1	38.6	40	40
						2NP04502058	20.0***	20.1	44.8	45	45
						2NP04502558	25.0***	25.1	51.0	60	60

¹ = Dual element, time delay type.² = Standard circuit breakers may be used in Canada and on applications over 60 amps where the heaters are separately fused.

* = KW listed is for 240 volts, use table on previous page for 208 or 230 volts.

** = KW listed is for 480 volts, use table on previous page for 460 volts.

*** = KW listed is for 600 volts, use table on previous page for 575 volts.

TABLE 7 - ELECTRICAL DATA (13 SEER HEAT PUMP / ELECTRIC HEAT)

MODEL BHZ/BUZ	POWER SUPPLY	COMPRESSOR		COND. FAN MOTOR FLA	SUPPLY AIR BLOWER MOTOR, FLA	ELECTRIC HEAT ACCESSORY			MINIMUM CIRCUIT AMPACITY	MAX. FUSE SIZE,① AMPS	MAX. HACR② BREAKER SIZE
		RLA	LRA			MODEL NO.	KW	TOTAL AMPS			
024	208/230-1-60	14.3	60	0.9	4.8	2NH04500506	3.8 / 5.0 *	18.1 / 20.8	44.3 / 47.7	50 / 50	50 / 50
						2NH04500706	5.6 / 7.5 *	27.1 / 31.3	55.6 / 60.8	60 / 70	60 / 70
						2NH04501006	7.5 / 10.0 *	36.1 / 41.7	66.8 / 73.8	70 / 80	70 / 80
030	208/230-1-60	16.4	72.5	1.0	4.8	2NH04500506	3.8 / 5.0 *	18.1 / 20.8	46.7 / 50.2	50 / 60	50 / 60
						2NH04500706	5.6 / 7.5 *	27.3 / 31.3	58.0 / 63.2	60 / 70	60 / 70
						2NH04501006	7.5 / 10.0 *	36.1 / 41.7	69.3 / 76.3	70 / 80	70 / 80
						2NH04501506	11.3 / 15.0 *	54.2 / 62.5	91.9 / 102.3	100 / 110	100 / 110
036	208/230-1-60	17.1	83.0	1.0	6.9	2NH04500506	3.8 / 5.0 *	18.1 / 20.8	49.7 / 53.2	60 / 60	60 / 60
						2NH04500706	5.6 / 7.5 *	27.1 / 31.3	61.0 / 66.2	70 / 70	70 / 70
						2NH04501006	7.5 / 10.0 *	36.1 / 41.7	72.3 / 79.2	80 / 80	80 / 80
						2NH04501506	11.3 / 15.0 *	54.2 / 62.5	94.9 / 105.3	100 / 110	100 / 110
042	208/230-1-60	20.7	105.0	1.1	6.9	2NP04501006	7.5 / 10.0 *	36.1 / 41.7	76.4 / 83.3	80 / 90	80 / 90
						2NP04501506	11.3 / 15.0 *	54.2 / 62.5	99.0 / 109.4	100 / 110	100 / 110
048	208/230-1-60	20.4	113.0	1.2	6.9	2NP04501006	7.5 / 10.0 *	36.1 / 41.7	79.6 / 86.6	90 / 90	90 / 90
						2NP04501506	11.3 / 15.0 *	54.2 / 62.5	102.2 / 112.6	110 / 125	110 / 125
						2NP04502006	15.0 / 20.0 *	72.2 / 83.3	124.8 / 138.6	125 / 150	125 / 150
						2NP04502506	18.8 / 25.0 *	90.3 / 104.2	147.3 / 164.7	150 / 175	150 / 175
060	208/230-1-60	26.3	150.0	1.7	8.9	2NP04501006	7.5 / 10.0 *	36.1 / 41.7	88.5 / 95.4	100 / 110	100 / 110
						2NP04501506	11.3 / 15.0 *	54.2 / 62.5	111.1 / 121.5	125 / 125	125 / 125
						2NP04502006	15.0 / 20.0 *	72.2 / 83.3	133.6 / 147.5	150 / 150	150 / 150
						2NP04502506	18.8 / 25.0 *	90.3 / 104.2	156.2 / 173.6	175 / 175	175 / 175
030	208/230-3-60	11.6	60.0	1.0	4.8	2NH04501025	7.5 / 10.0 *	20.8 / 24.1	44.9 / 48.9	50 / 50	50 / 50
						2NH04501525	11.3 / 15.0 *	31.3 / 36.1	57.9 / 63.9	60 / 70	60 / 70
036	208/230-3-60	12.9	77.0	1.0	6.9	2NH04501025	7.5 / 10.0 *	20.8 / 24.1	48.3 / 52.3	50 / 60	50 / 60
						2NH04501525	11.3 / 15.0 *	31.3 / 36.1	61.4 / 67.4	70 / 70	70 / 70
042	208/230-3-60	15.3	88.0	1.1	6.9	2NP04501025	7.5 / 10.0 *	20.8 / 24.1	50.8 / 54.8	60 / 60	60 / 60
						2NP04501525	11.3 / 15.0 *	31.3 / 36.1	63.8 / 69.9	70 / 70	70 / 70
048	208/230-3-60	16.0	120.0	1.2	6.9	2NP04501025	7.5 / 10.0 *	20.8 / 24.1	54.2 / 58.2	60 / 60	60 / 60
						2NP04501525	11.3 / 15.0 *	31.3 / 36.1	67.2 / 73.2	70 / 80	70 / 80
						2NP04502025	15.0 / 20.0 *	41.7 / 48.1	80.2 / 88.2	90 / 90	90 / 90
						2NP04502525	18.8 / 25.0 *	52.1 / 60.1	93.3 / 103.3	100 / 110	100 / 110
060	208/230-3-60	17.6	120.0	1.7	8.9	2NP04501025	7.5 / 10.0 *	20.8 / 24.1	59.0 / 63.0	70 / 70	70 / 70
						2NP04501525	11.3 / 15.0 *	31.3 / 36.1	72.1 / 78.1	80 / 80	80 / 80
						2NP04502025	15.0 / 20.0 *	41.7 / 48.1	85.1 / 93.1	90 / 100	90 / 100
						2NP04502525	18.8 / 25.0 *	52.1 / 60.1	98.1 / 108.2	100 / 110	100 / 110
030	460-3-60	5.0	31.0	0.5	2.4	2NH04501046	10.0**	12.0	23.6	25	25
						2NH04501546	15.0**	18.0	31.1	35	35
036	460-3-60	5.7	35.0	0.5	3.5	2NH04501046	10.0**	12.0	25.4	30	30
						2NH04501546	15.0**	18.0	32.9	35	35
042	460-3-60	7.1	39.0	0.6	3.5	2NP04501046	10.0**	12.0	27.1	30	30
						2NP04501546	15.0**	18.0	34.7	35	35
048	460-3-60	8.3	60.0	0.6	3.5	2NP04501046	10.0**	12.0	29.5	30	30
						2NP04501546	15.0**	18.0	37.0	40	40
						2NP04502046	20.0**	24.1	44.5	45	45
						2NP04502546	25.0**	30.1	50.4	60	60
060	460-3-60	9.6	70.0	0.9	4.5	2NP04501046	10.0**	12.0	32.4	35	35
						2NP04501546	15.0**	18.0	40.0	45	45
						2NP04502046	20.0**	24.1	47.5	50	50
						2NP04502546	25.0**	30.1	55.0	60	60

① = Dual element, time delay type.

② = Standard circuit breakers may be used in Canada and on applications

* = KW listed is for 240 volts, use table on previous page for 208 or 230 volts.

** = KW listed is for 480 volts, use table on previous page for 460 volts.

